

2018

Trim Catalog



HOMESTEAD
WOODWORKS

TABLE OF CONTENTS

Casing.....	2-21
Back Band.....	22-28
Base Board.....	29-38
Crown Mould.....	39-61
Panel Mould.....	62-79
Chair Rail.....	80-85
Door Stop.....	86-92
Window Sill.....	93-96
T & G Paneling.....	97-100
Shiplap.....	101-104
Hand Rail.....	105-111
Plinth Block.....	112-116
Brick Mould.....	117-121

www.hsww.ca

Homestead Woodworks
3575 Broadway St.
Hawkesville, ON
519 699 4529



HOMESTEAD
WOODWORKS

Casing

- Most CB profiles can be used for both casing and base.
- Most CB molding can be modified to some degree.
- Standard casing thickness is 13/16".
- Standard base thickness is 11/16".
- Back checking is optional.

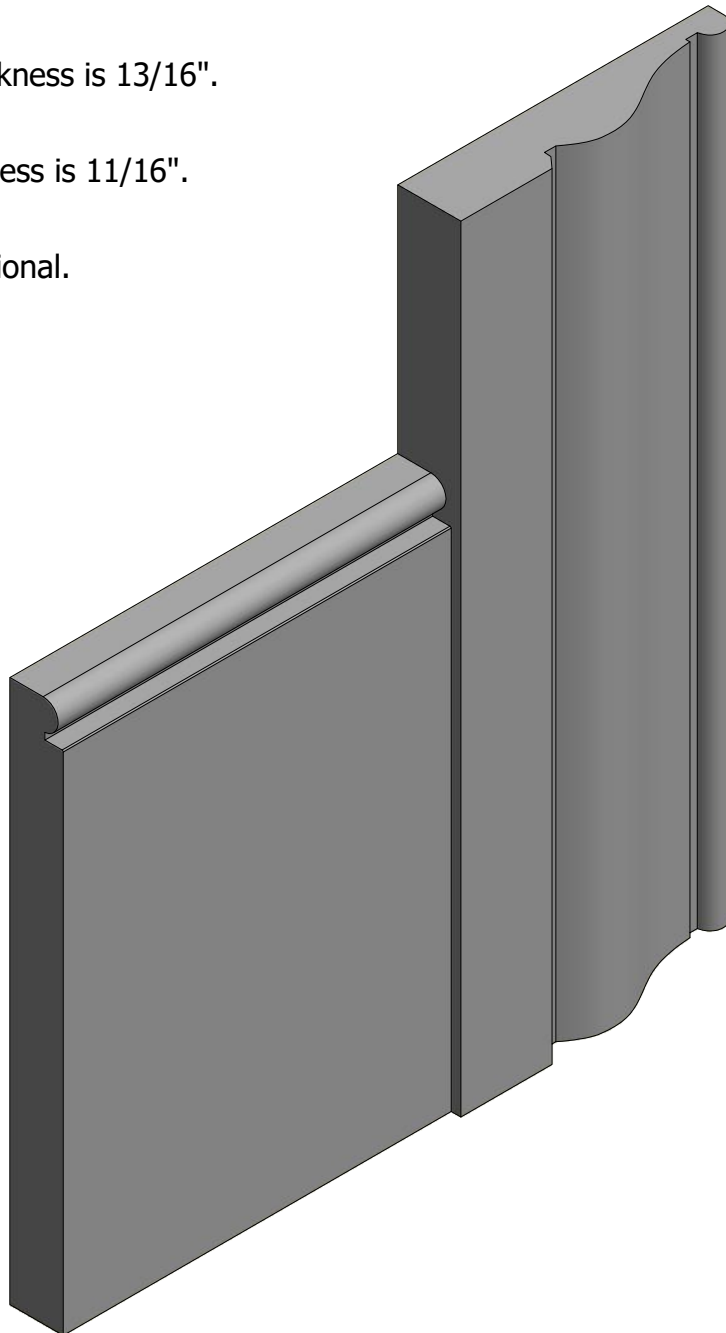

CB-01

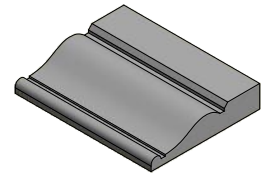
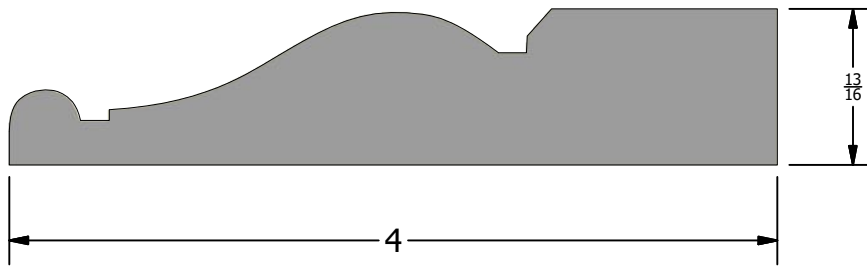

CB-02

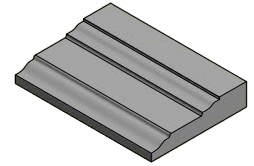
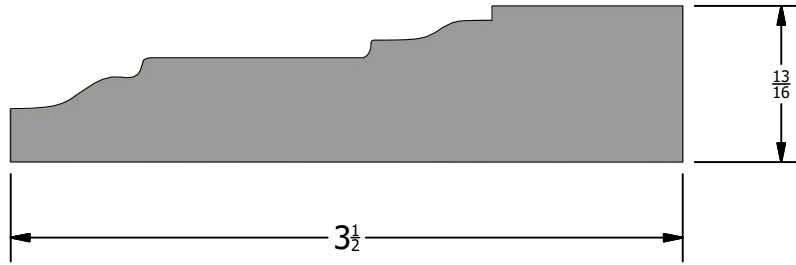

CB-03

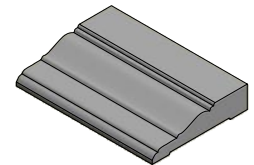
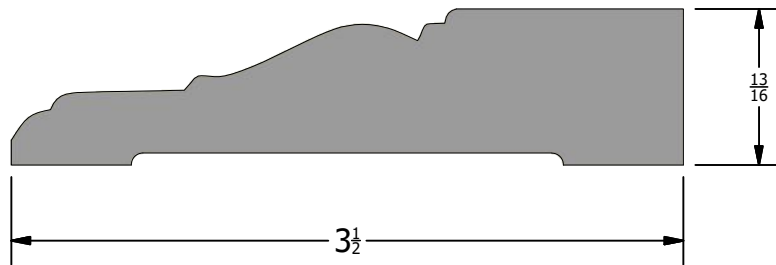

CB-04

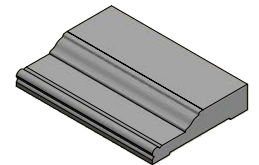
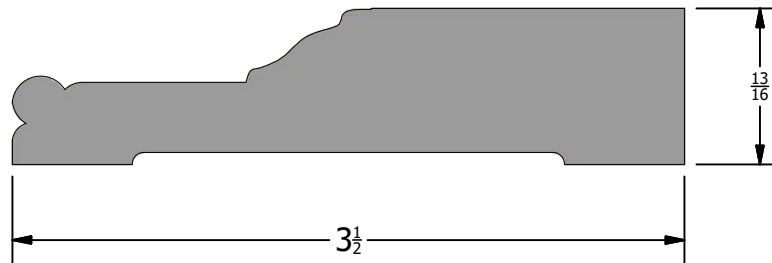

CB-05

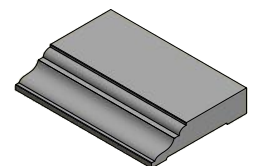
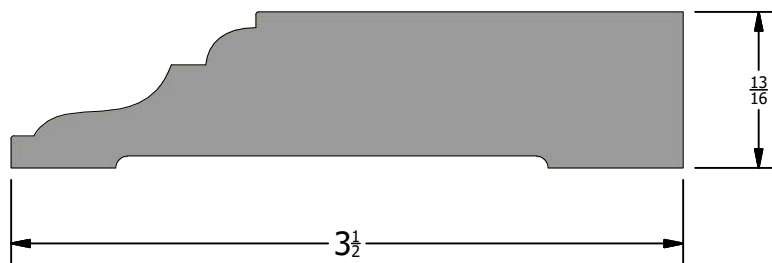

CB-06-A

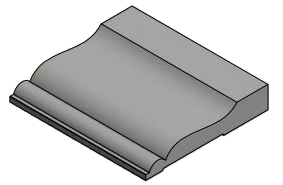
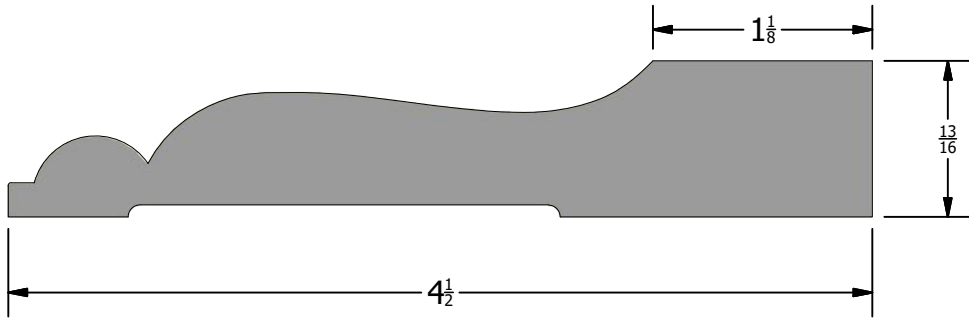

CB-06-B

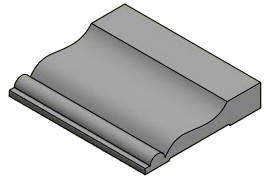
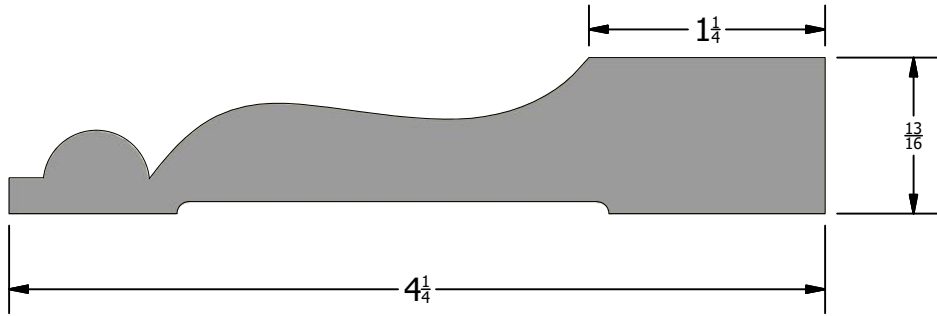

CB-07

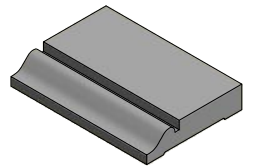
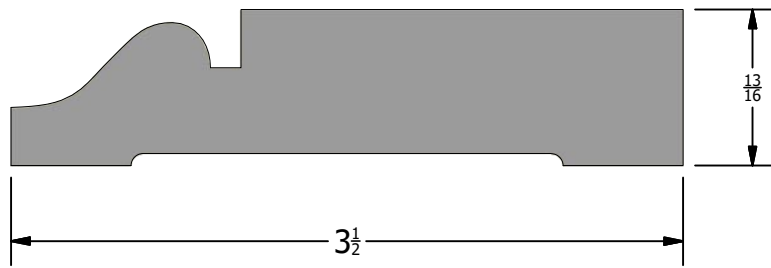

CB-08

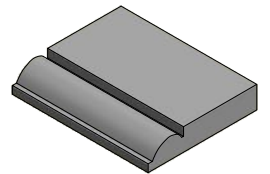
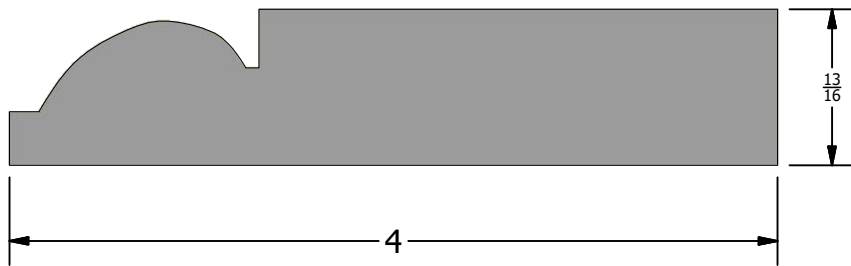

CB-09

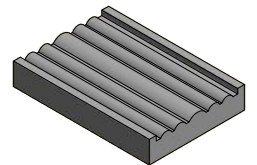
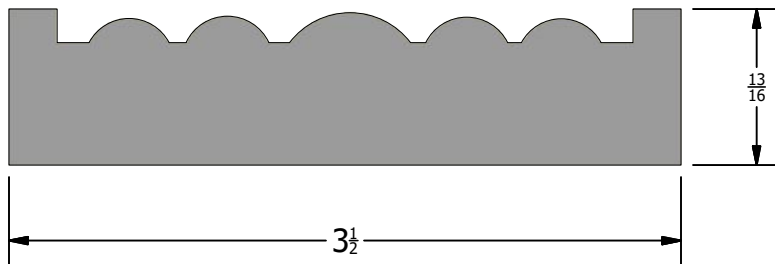

CB-10

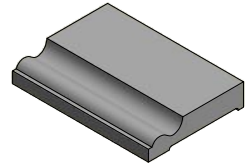
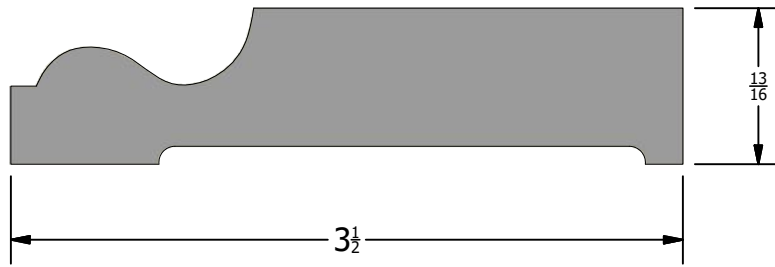

CB-11

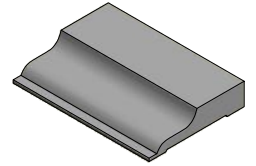
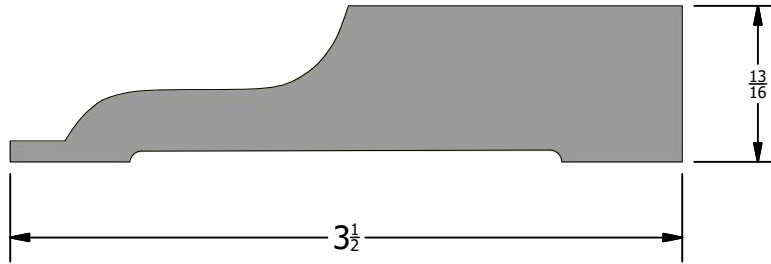

CB-12

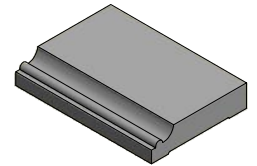
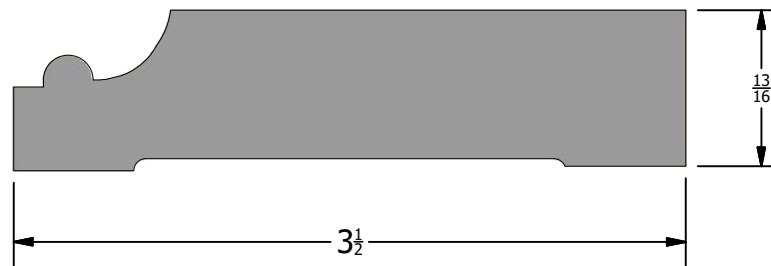

CB-13

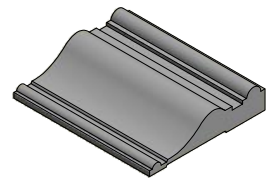
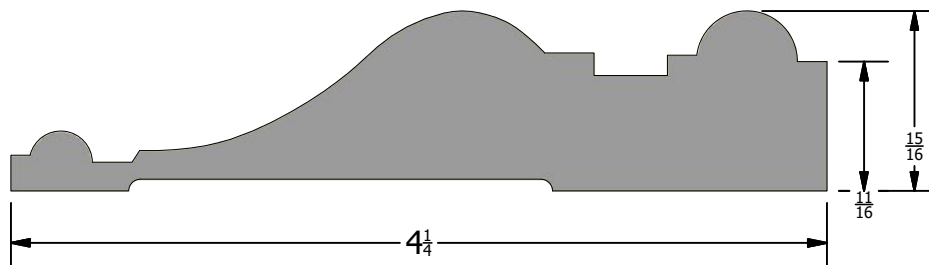

CB-14

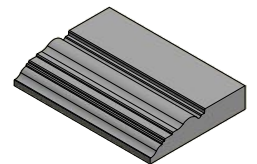
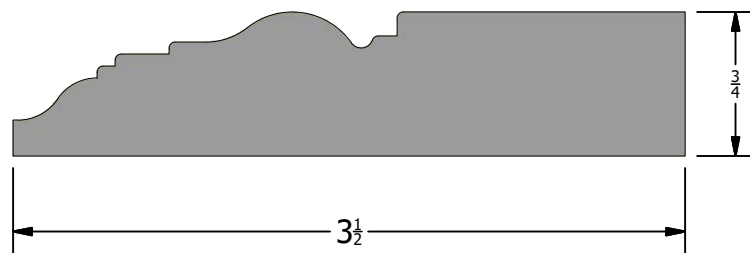

CB-15

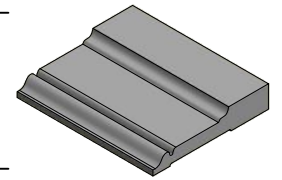
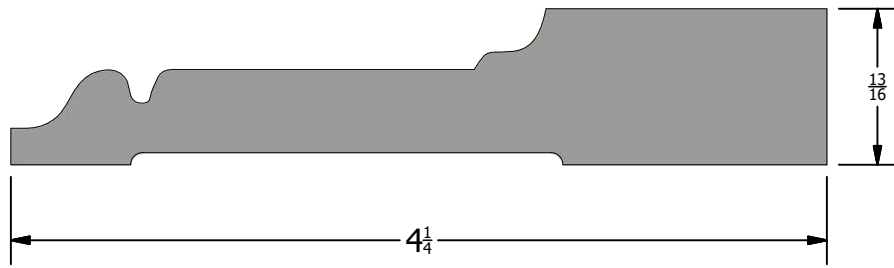

CB-16

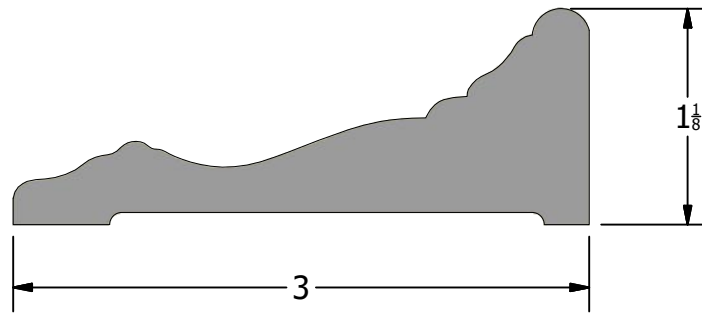

CB-17

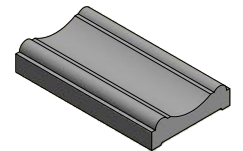
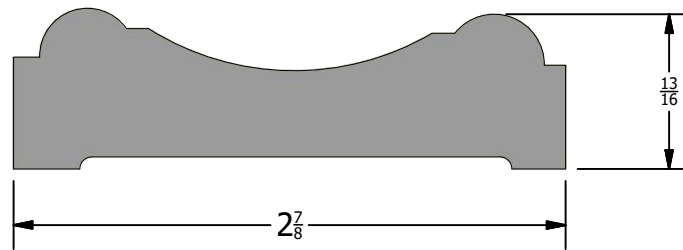

CB-18

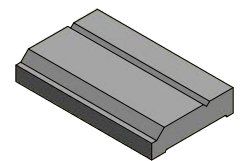
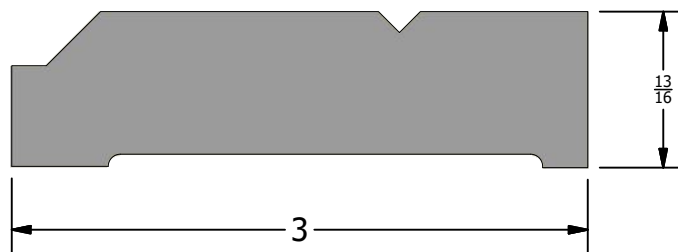

CB-19

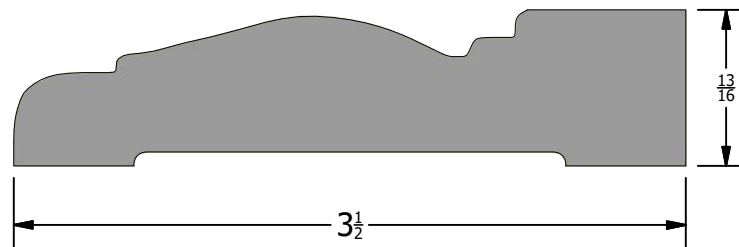

CB-20

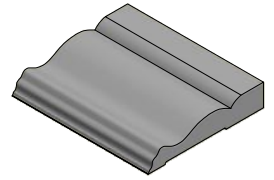
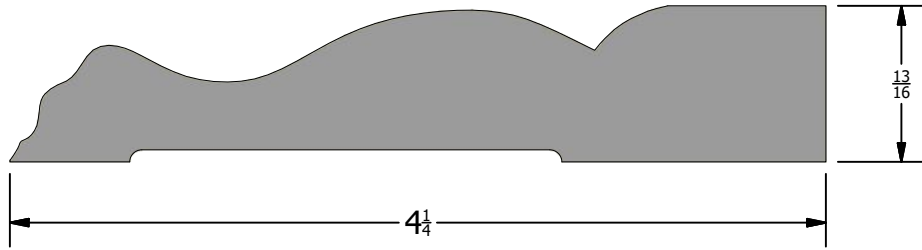

CB-21

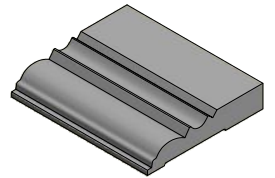
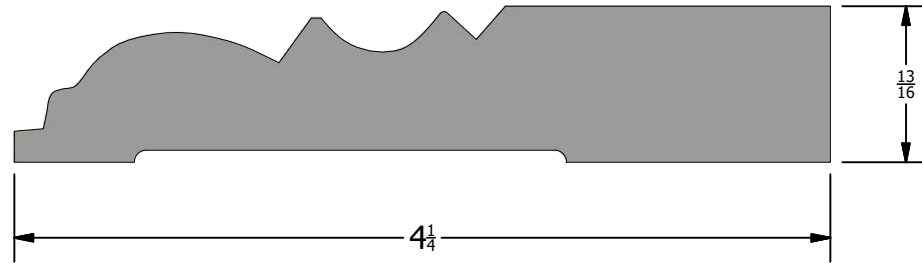

CB-22

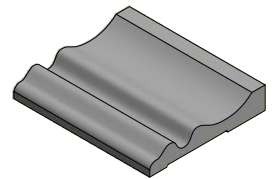
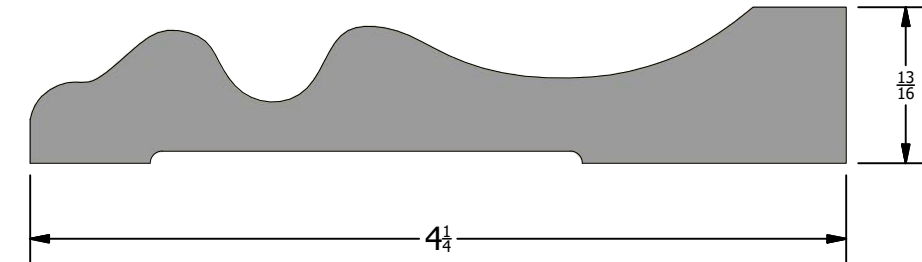

CB-23

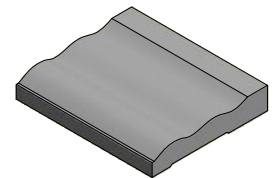
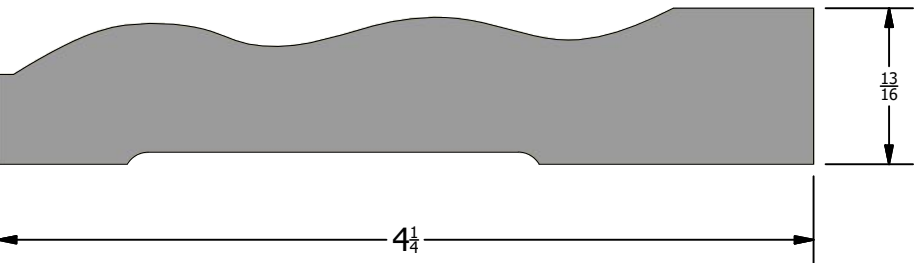

CB-24

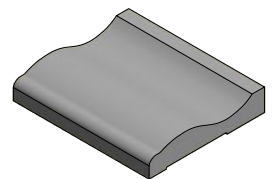
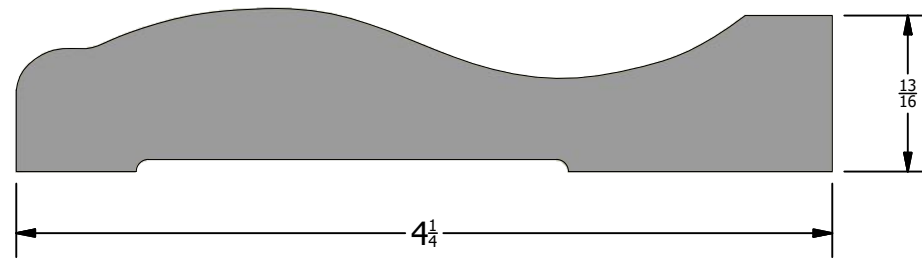

CB-25

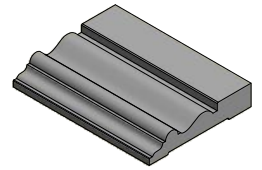
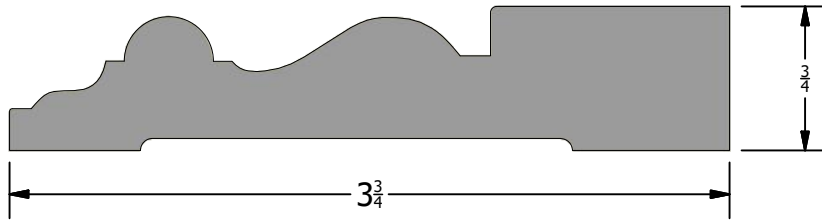

CB-26

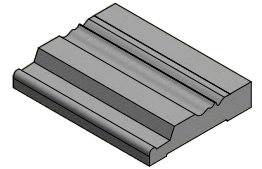
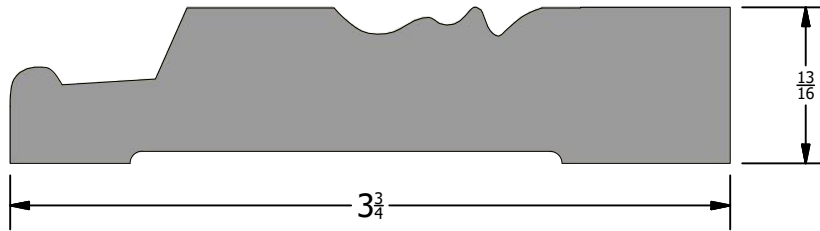

CB-27

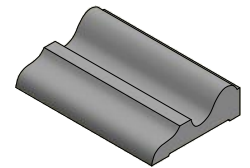
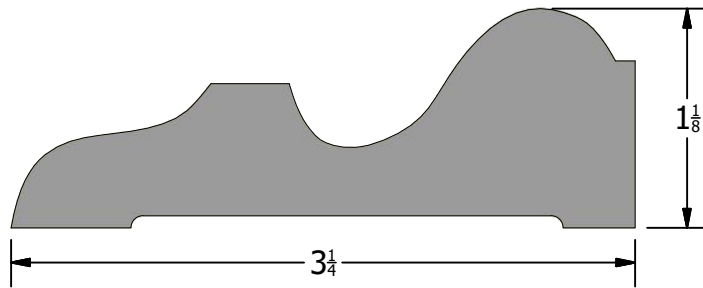

CB-28 -A

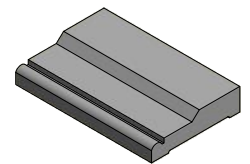
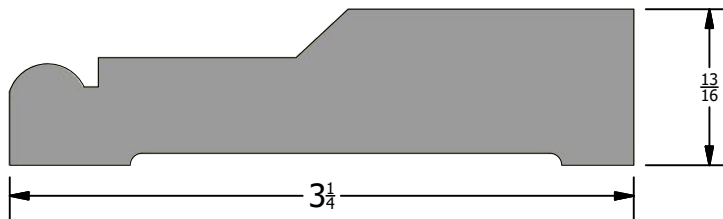

CB-28-B

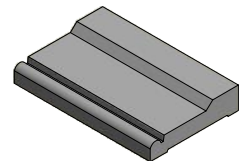
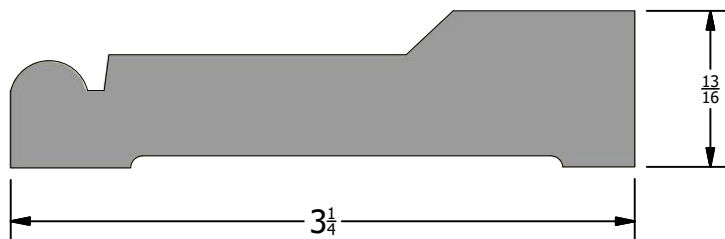

CB-28-C

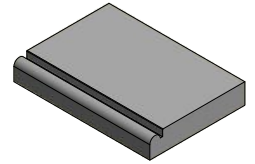
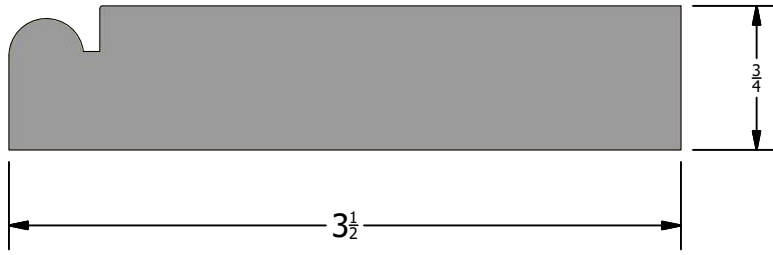

CB-28-D

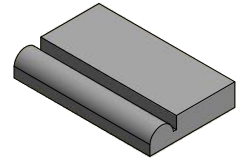

CB-28-E

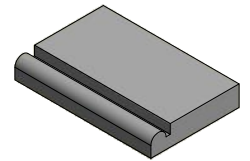
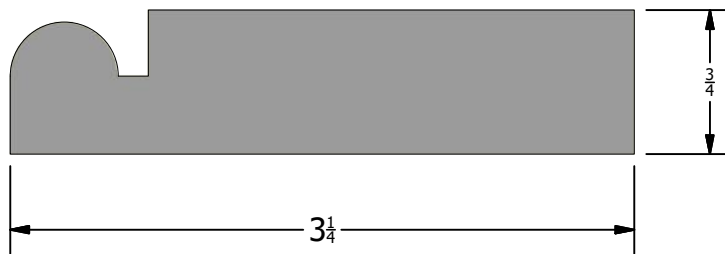

CB-29

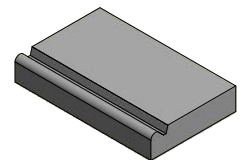
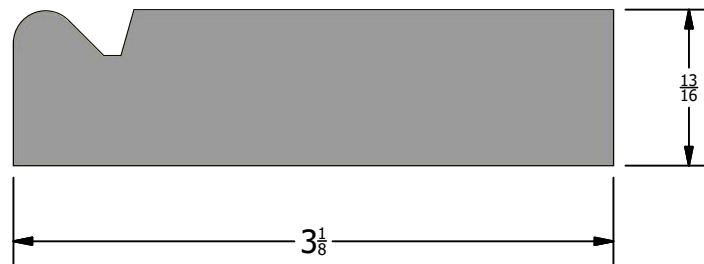

CB-30

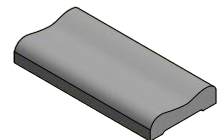
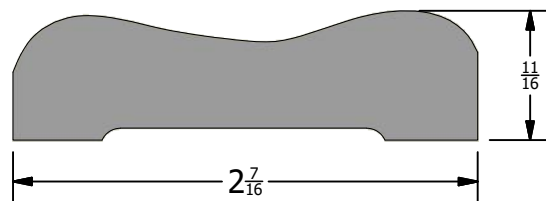

CB-31

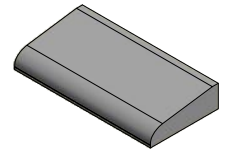
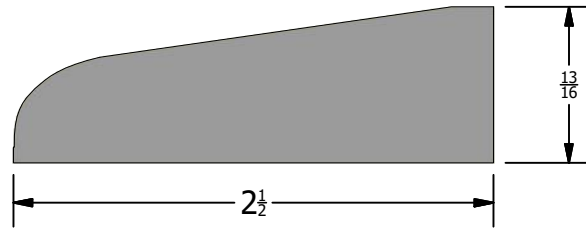

CB-32

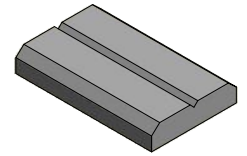
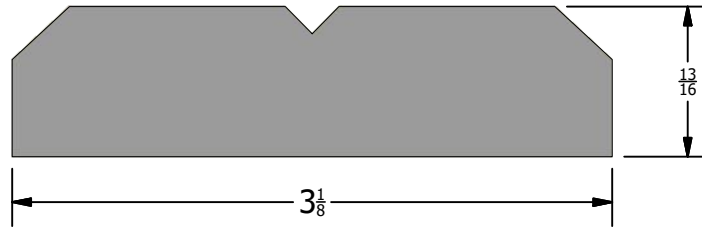

CB-33

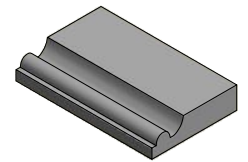
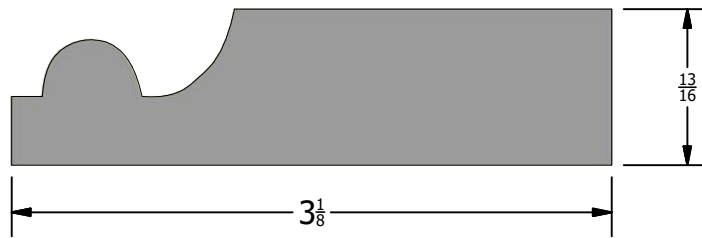

CB-34

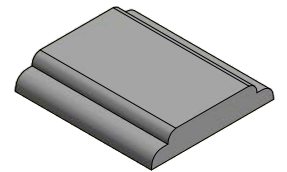
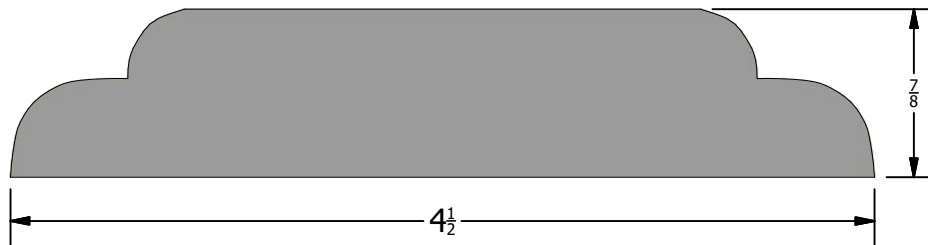

CB-35

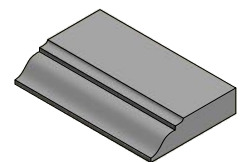
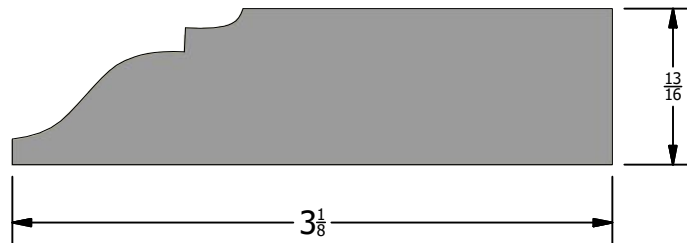

CB-36

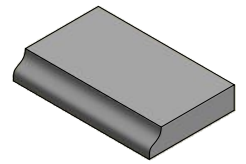
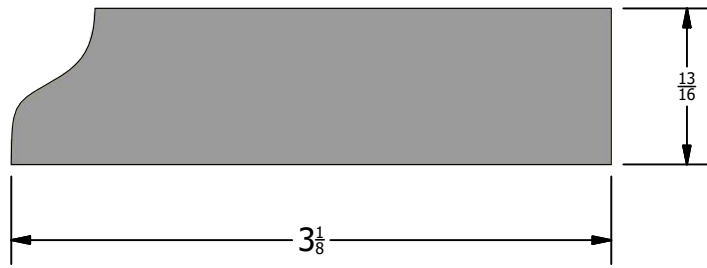

CB-37

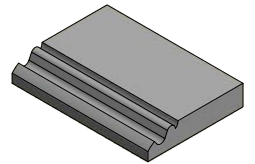
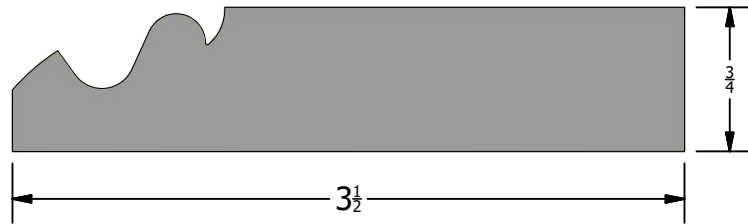

CB-38

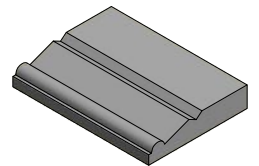
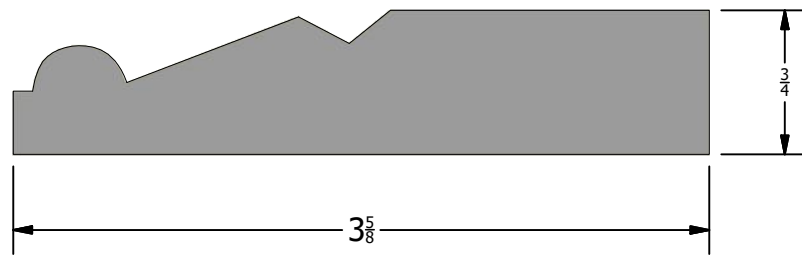

CB-39

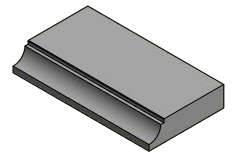
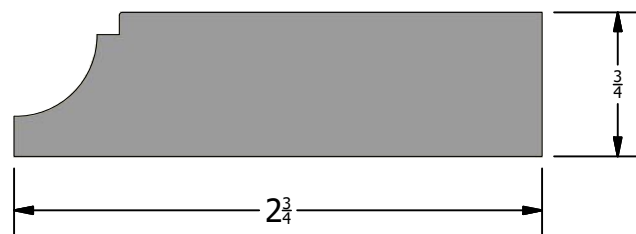

CB-40

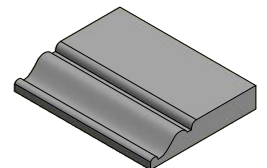
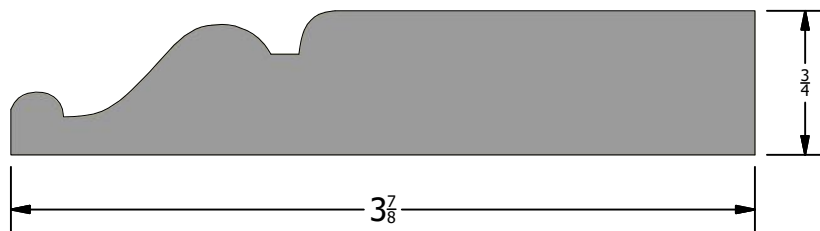

CB-41

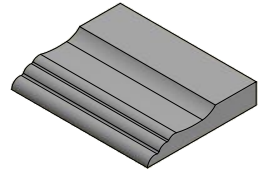
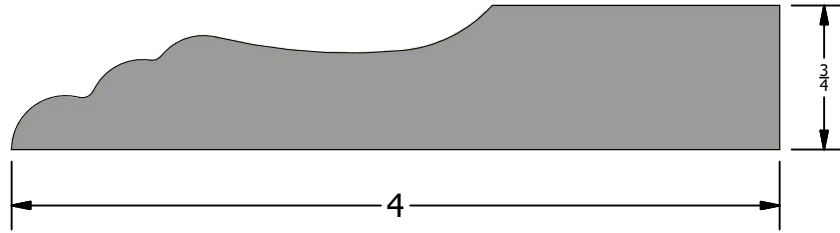

CB-42

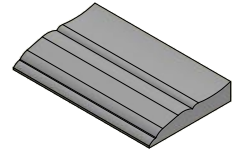
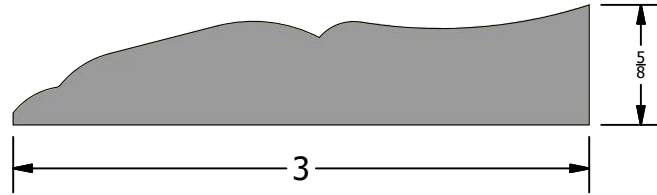

CB-43

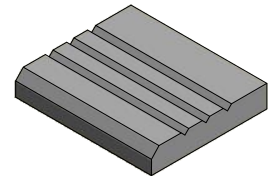
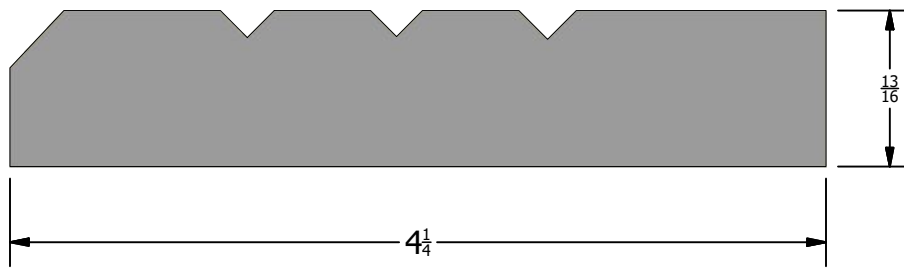

CB-44

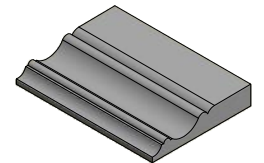
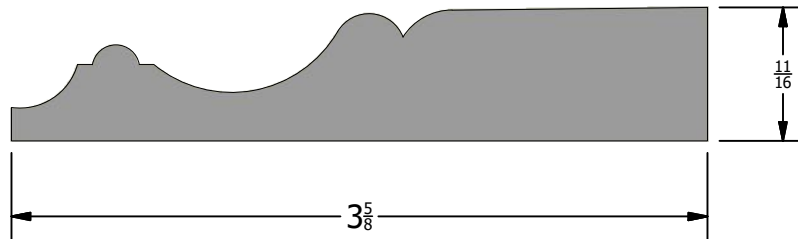

CB-45

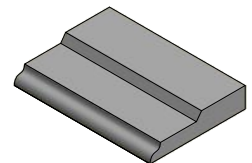
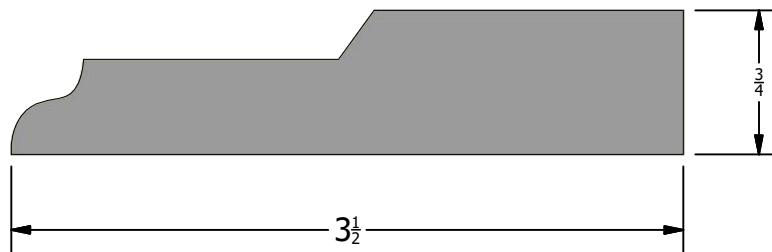

CB-46

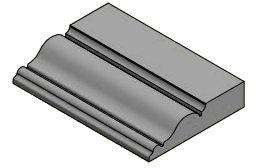
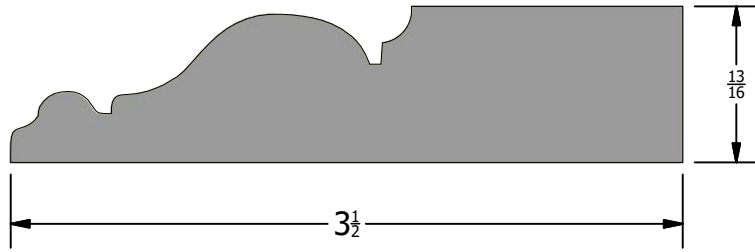

CB-47

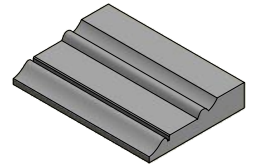
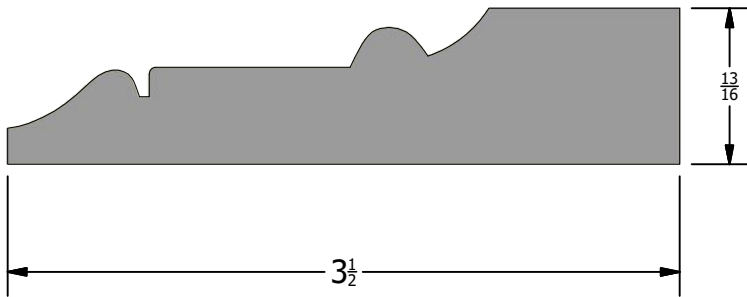

CB-48-A

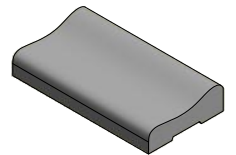
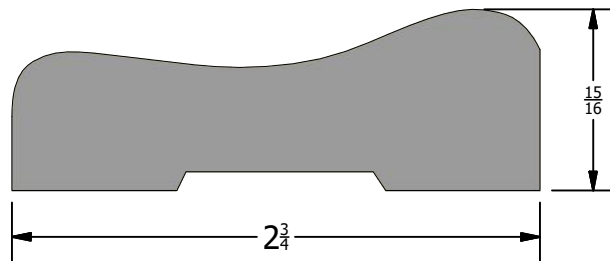

CB-48-B

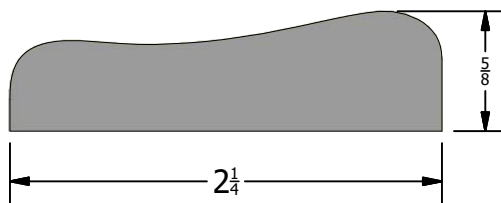

CB-49

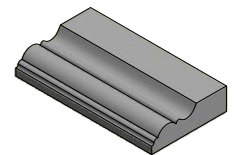
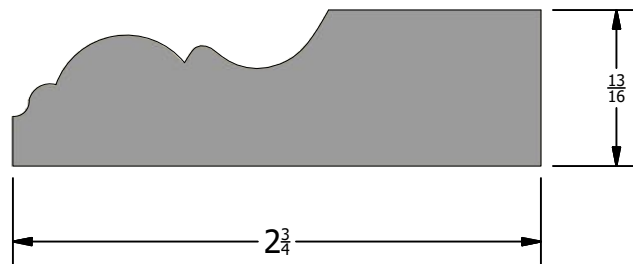

CB-50

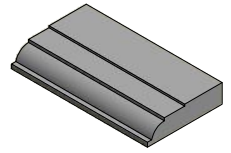
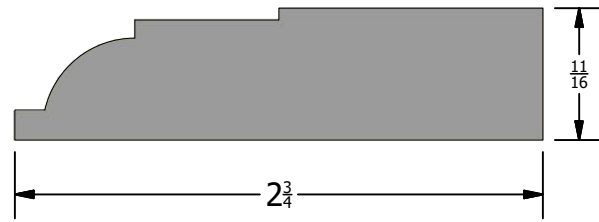

CB-51

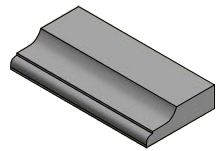
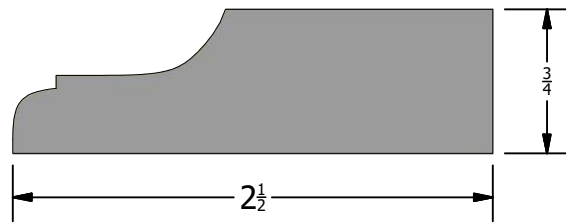

CB-52

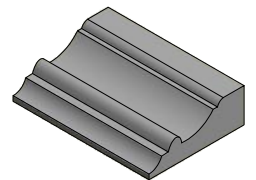
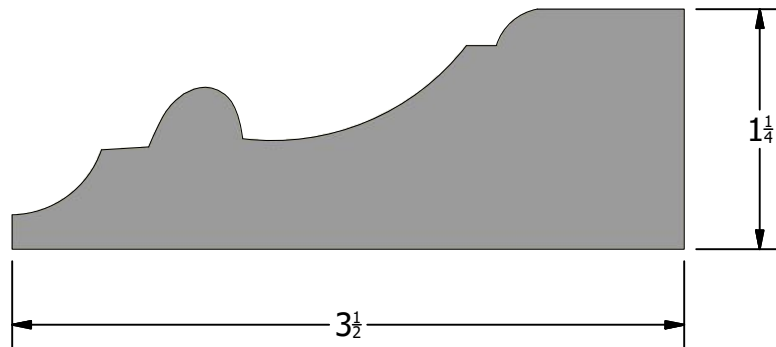

CB-53-A

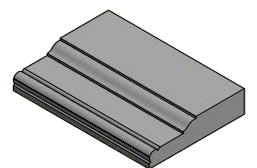
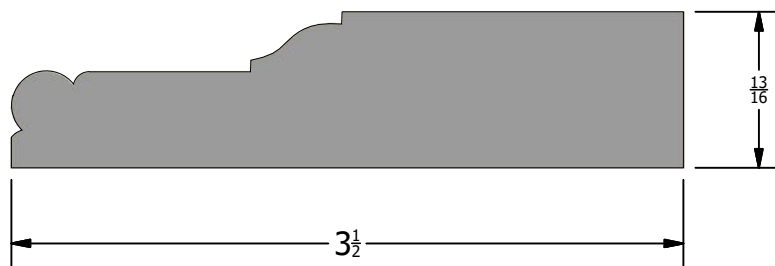

CB-53-B

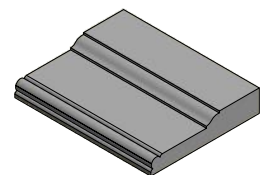
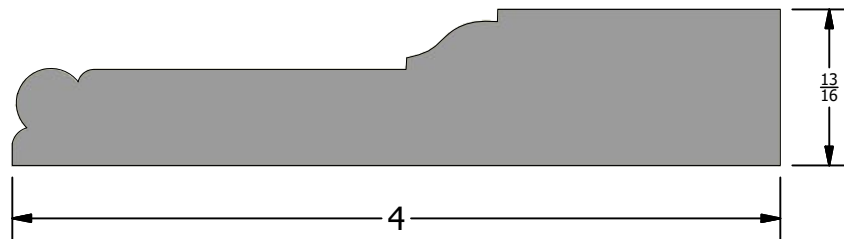

CB-54

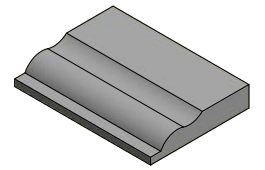
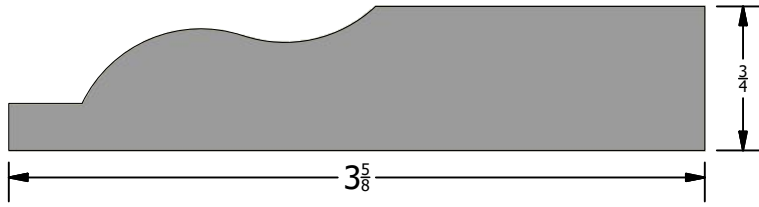

CB-55

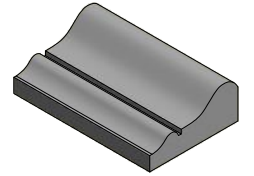
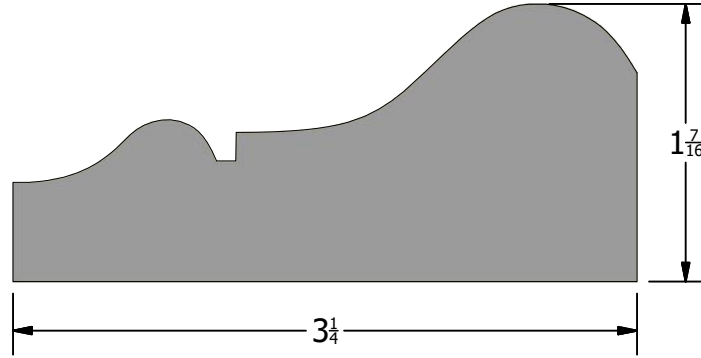

CB-56

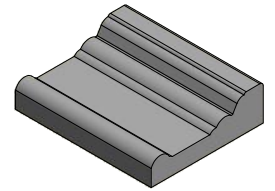
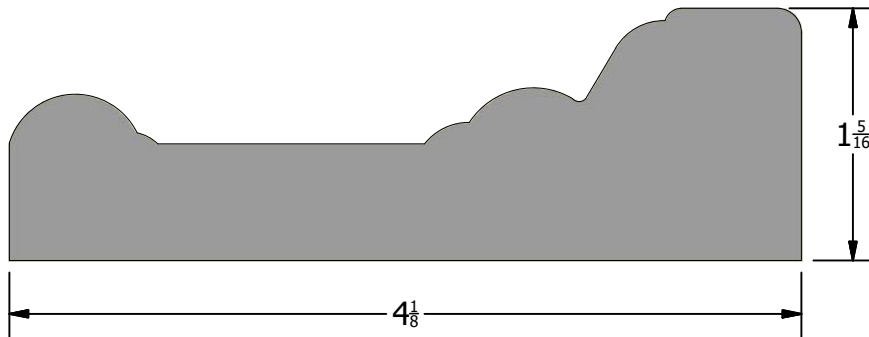

CB-57

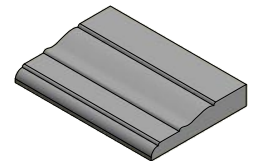
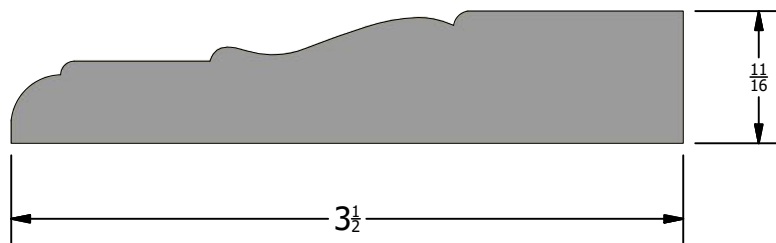

CB-58

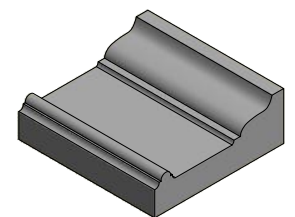
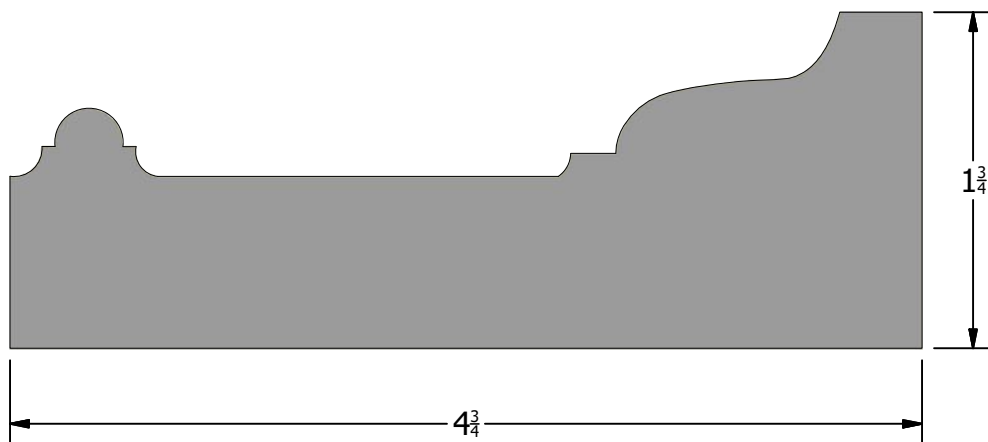

CB-59

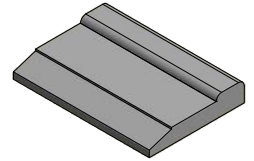
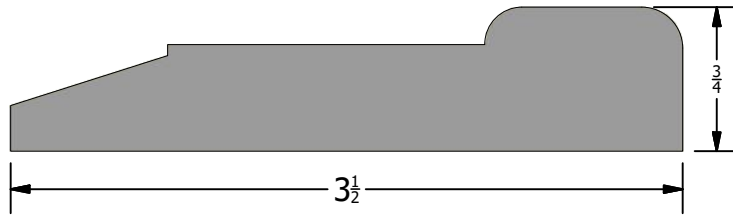

CB-60

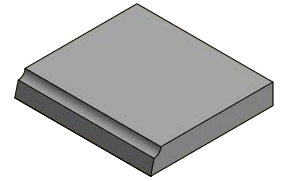
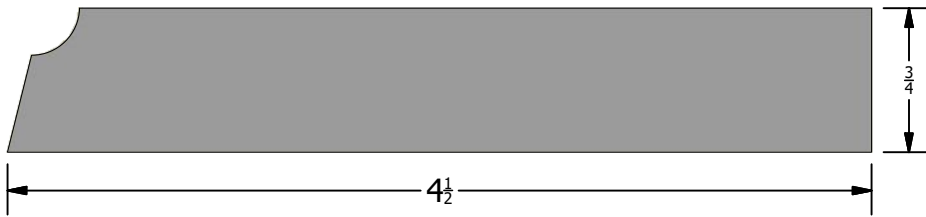

CB-61

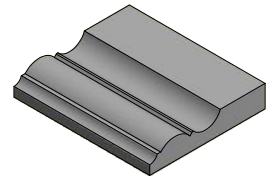
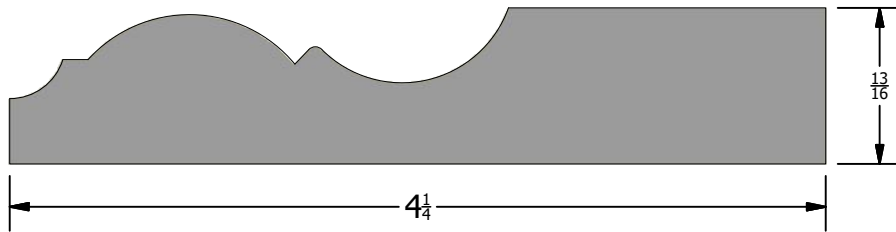

CB-62

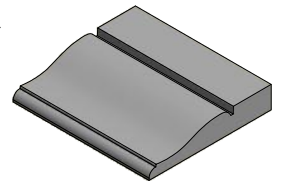
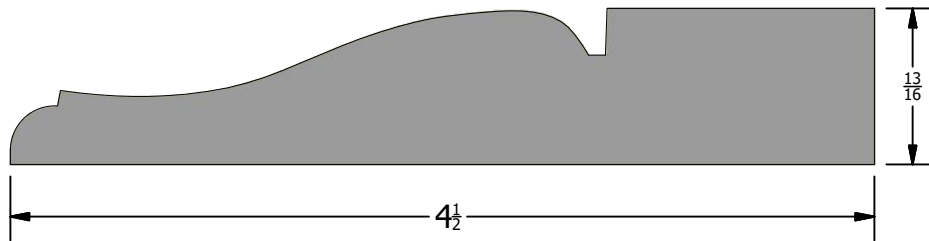

CB-63

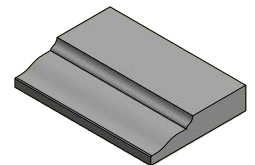
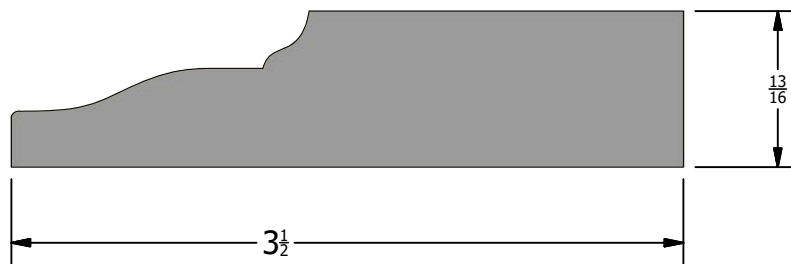

CB-64

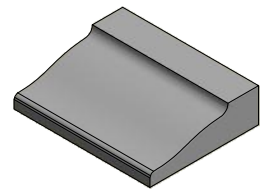
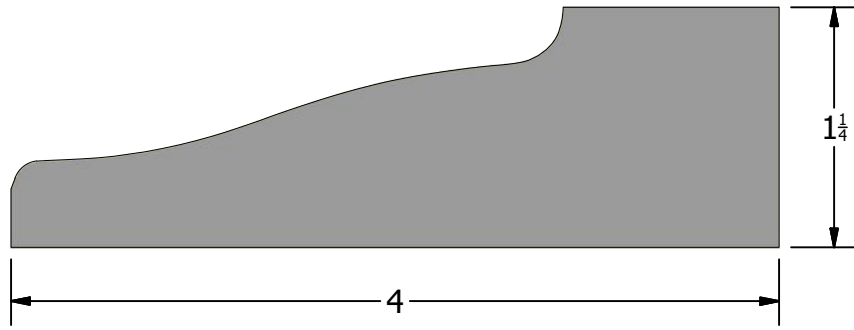

CB-65

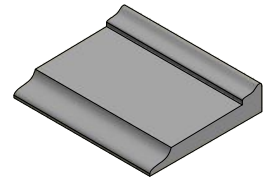
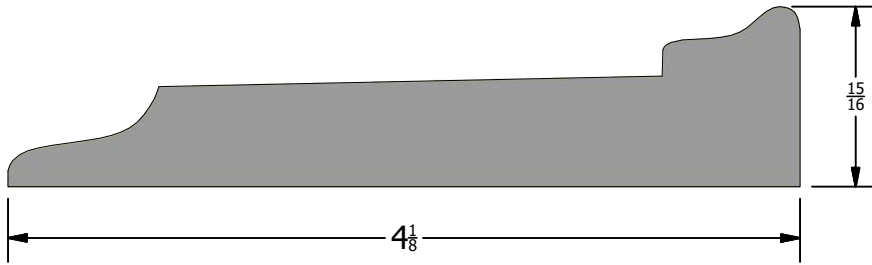

CB-67

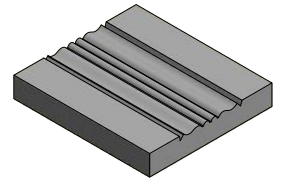
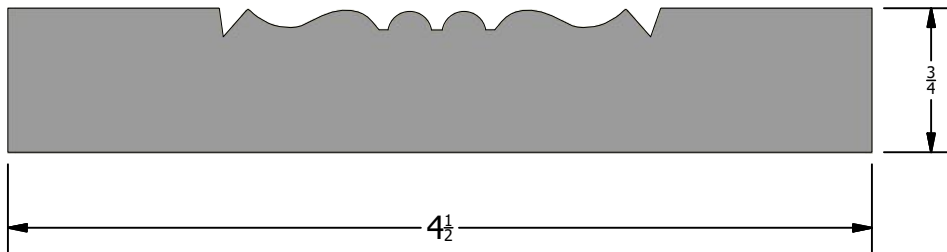

CB-68

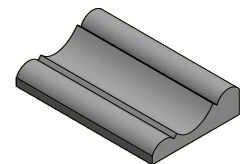
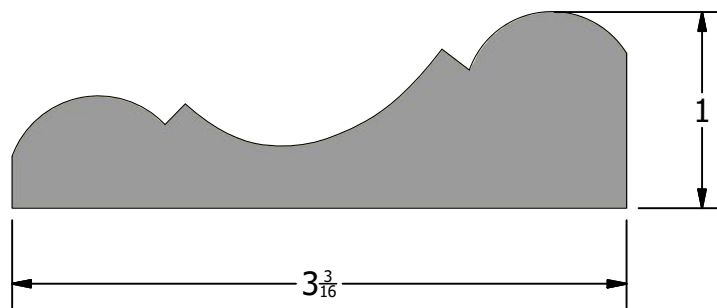

CB-69

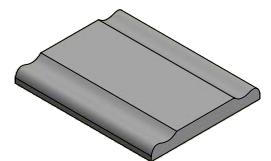
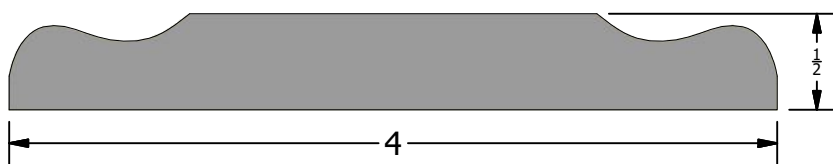

CB-70

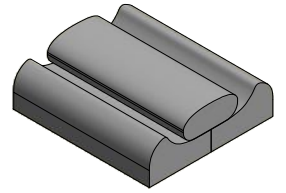
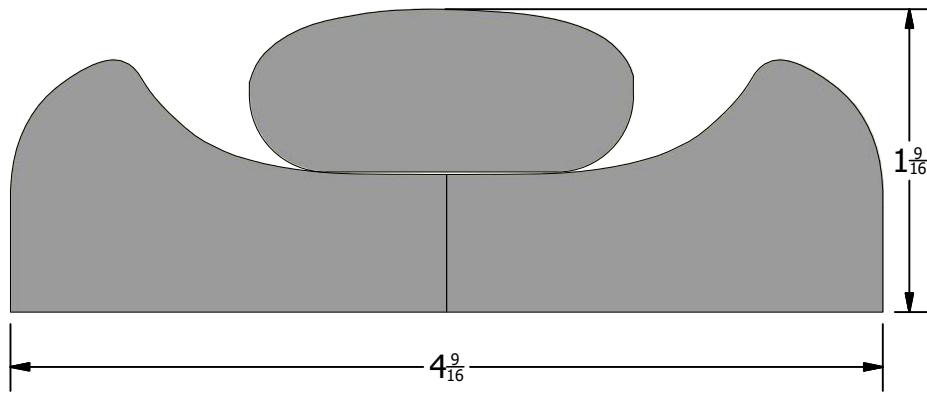

CB-71

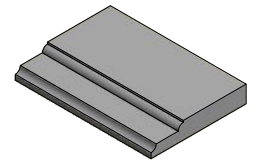
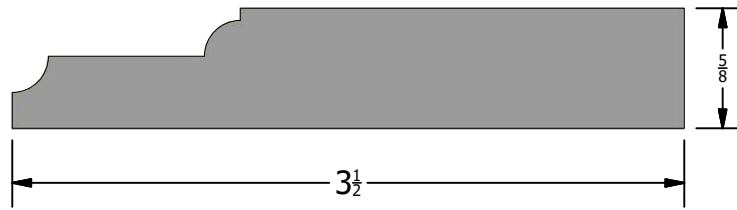

CB-72-A

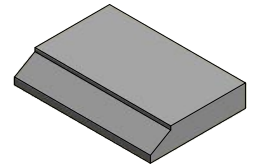
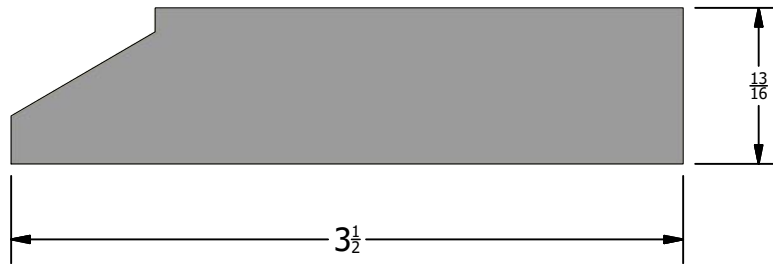

CB-72-B

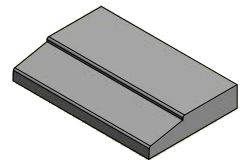
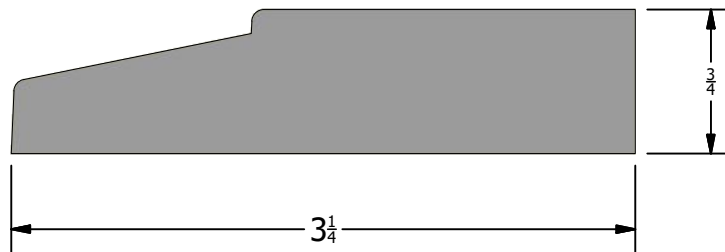

CB-72-C

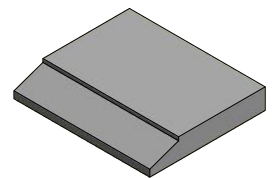
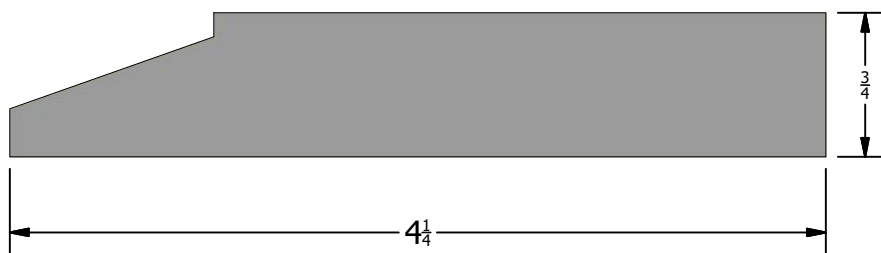

CB-73

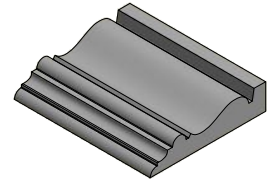
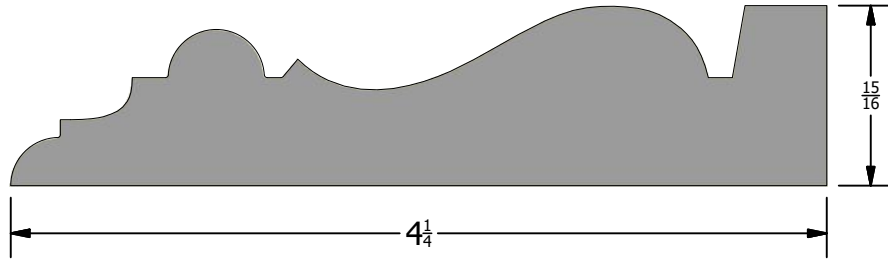

CB-74

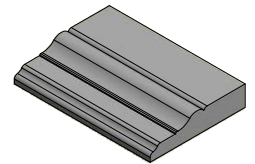
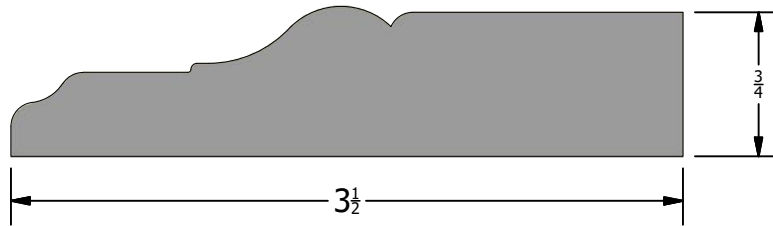

CB-75

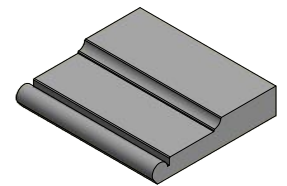
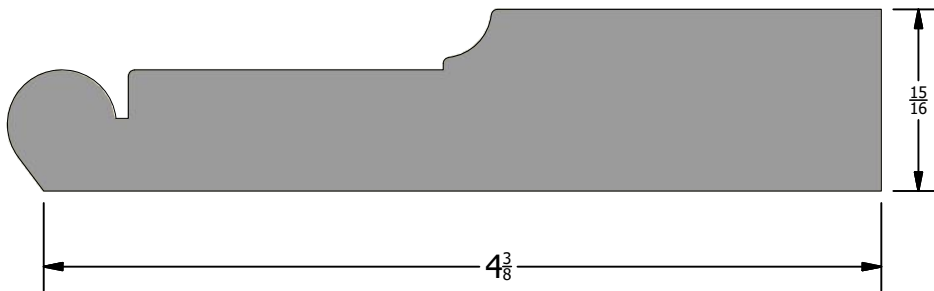

CB-76

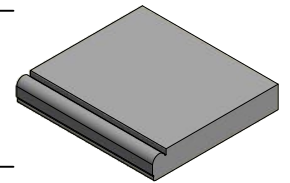
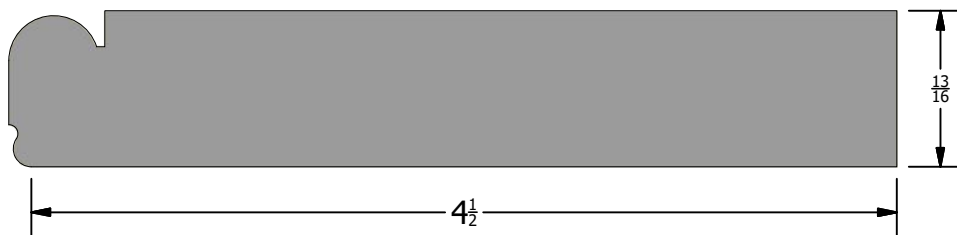

CB-77

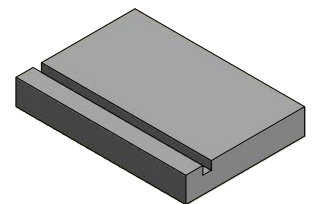
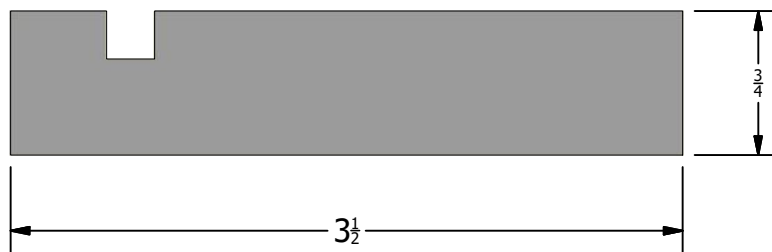

CB-78

Scale
1 / 2

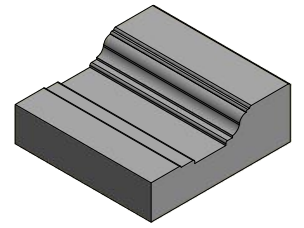
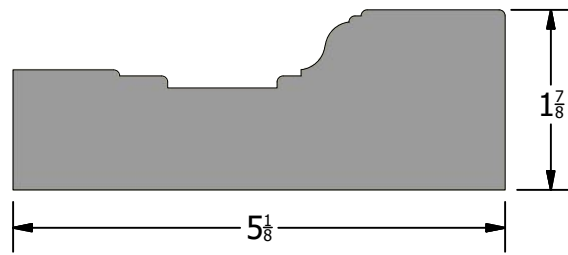

CB-79

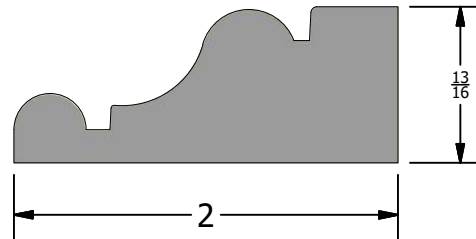

CB-80

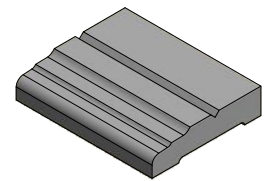
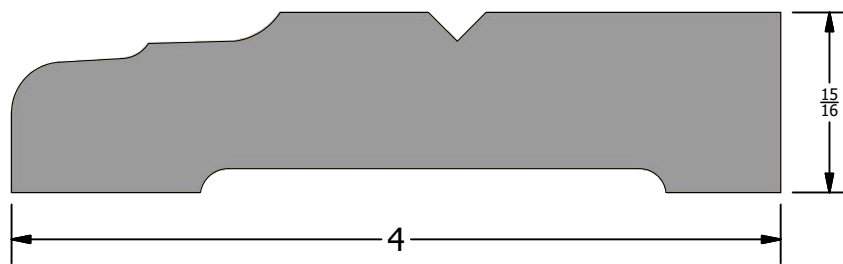

CB-81

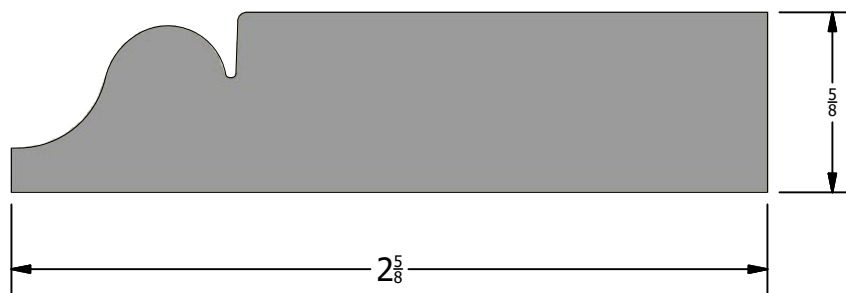

Back Band

- Standard lap is 1/4" but can be modified.
- Heights adjust according to casing thickness.
- Most back band can be modified on the back edge to add or remove width or a step detail.



BB-01

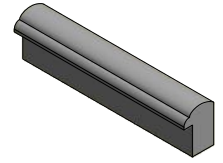
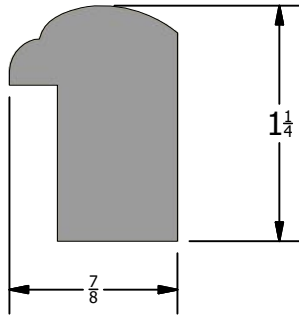

BB-02

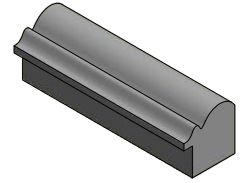
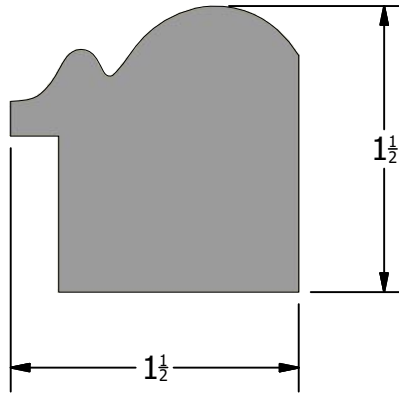

BB-03-A

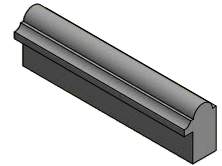
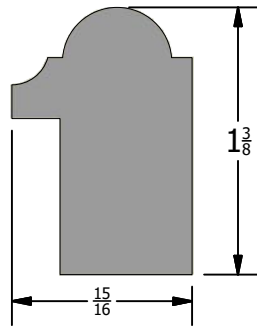

BB-03-B

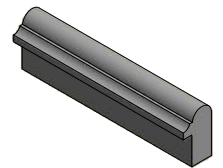
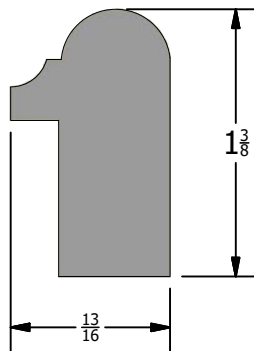

BB-04

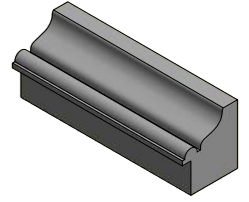
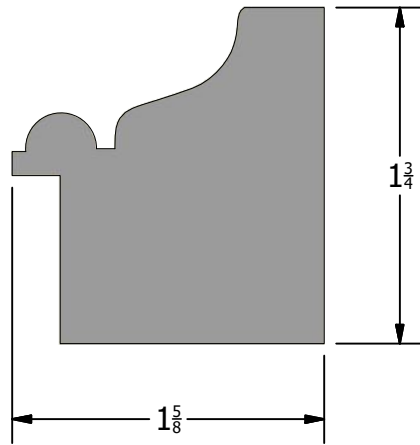

BB-05

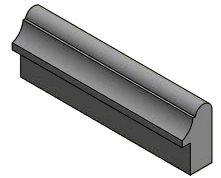
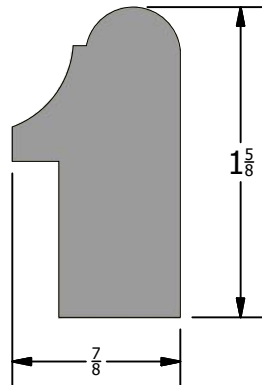

BB-06

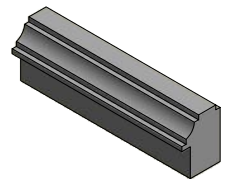
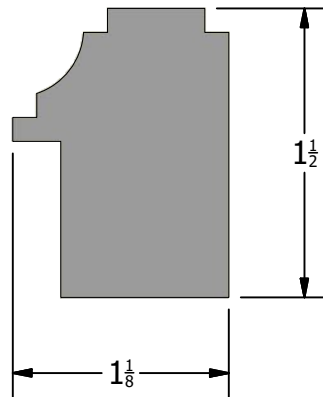

BB-07

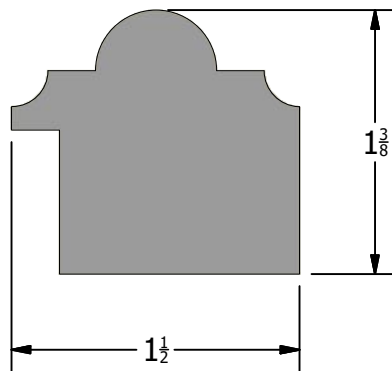

BB-08

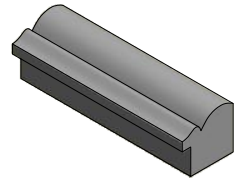
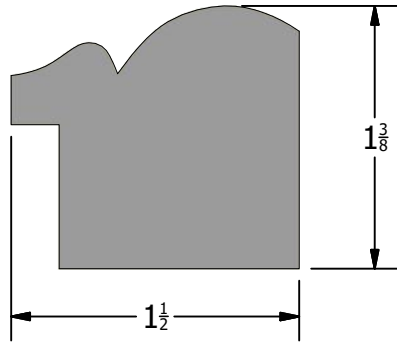

BB-09

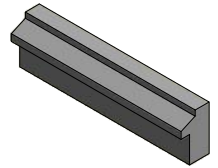
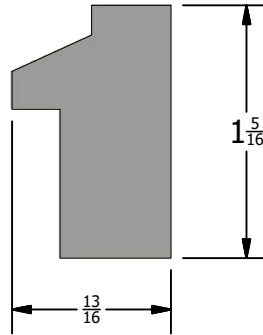

BB-10

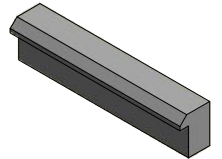
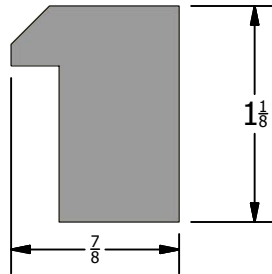

BB-11-A

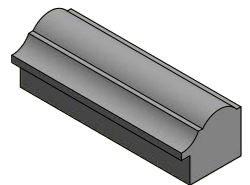
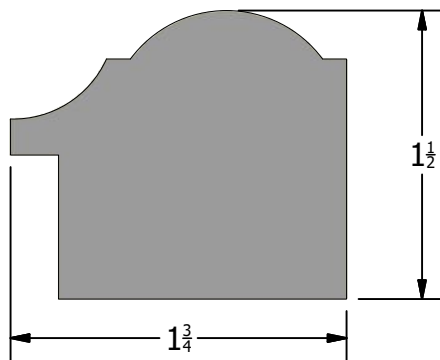

BB-11-B

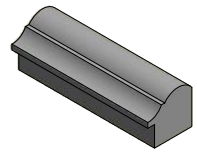
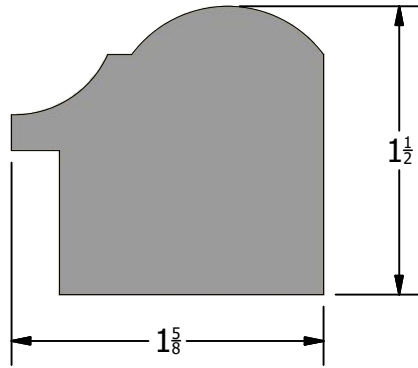

BB-12

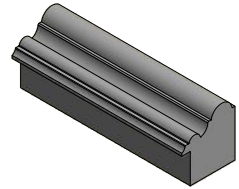
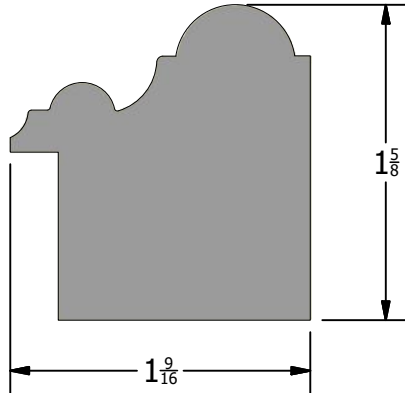

BB-13

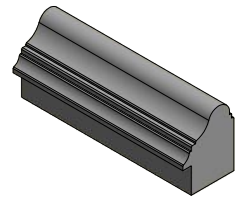
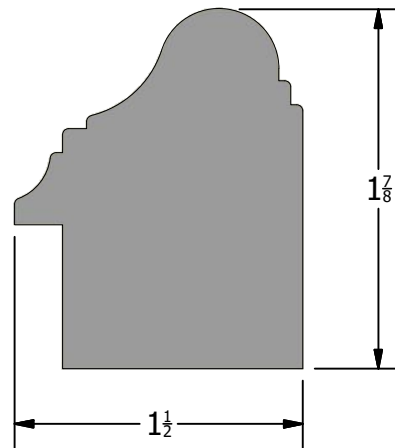

BB-14

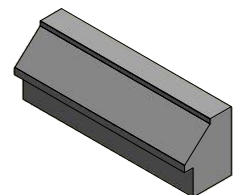
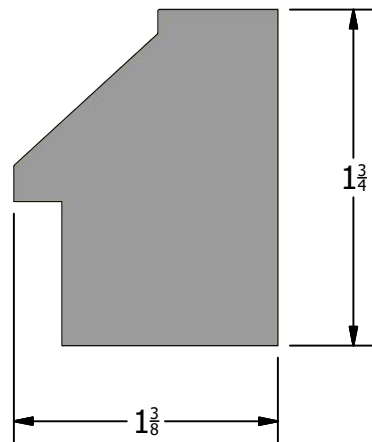

BB-15

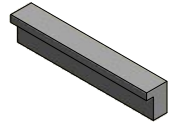
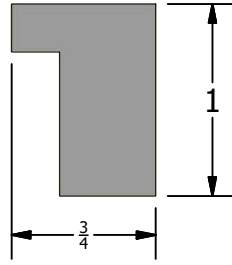

Base Board

-CB moulds used as base are standard thickness of 11/16".

-Most of the following base moulds need to be as the thickness shown or thicker.

-Both CB & base moulds can be stacked to achieve a taller base and control material shrinkage.

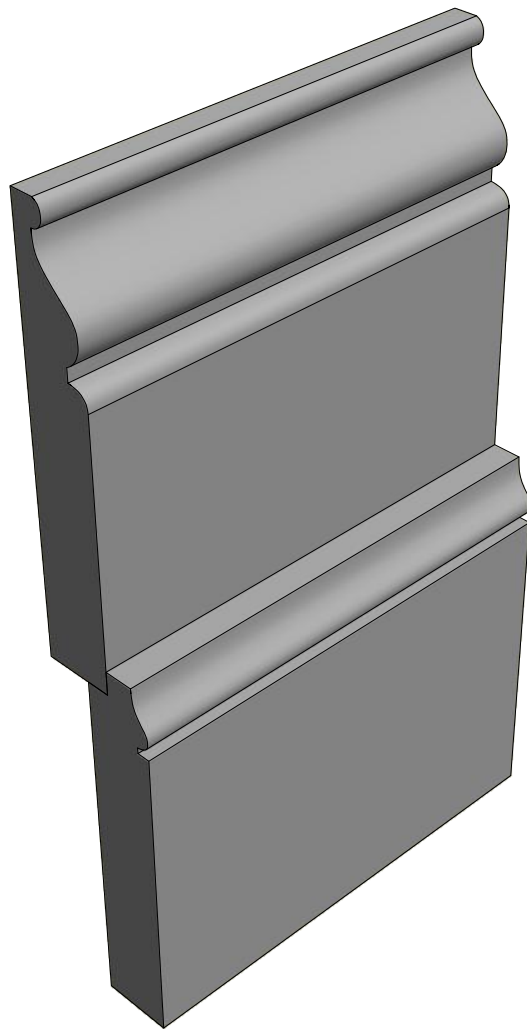

Base-01

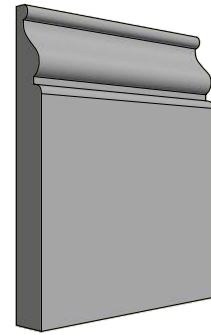
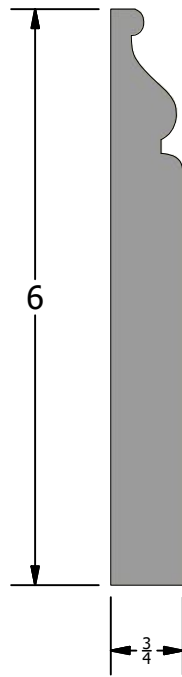

Base-02

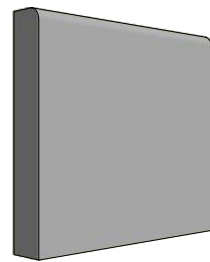
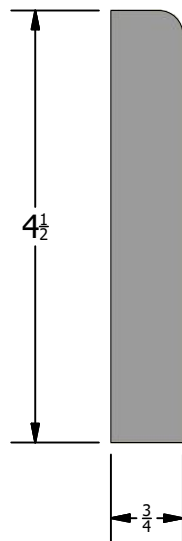

Base-03
Scale
1 / 2

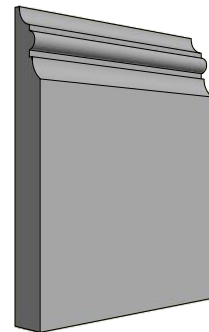
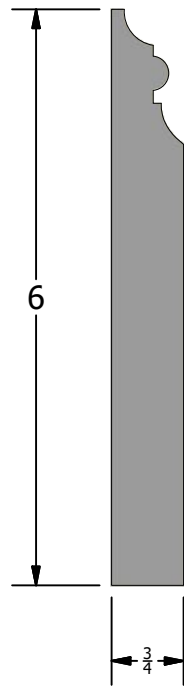

Base-04
Scale
1 / 2

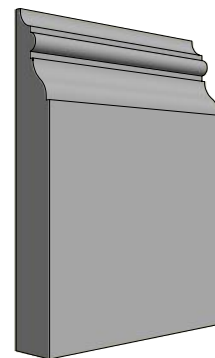
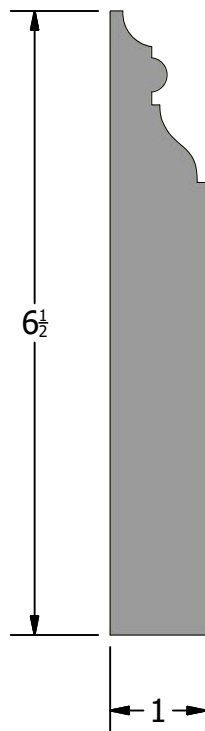

Base-05
Scale
1 / 2

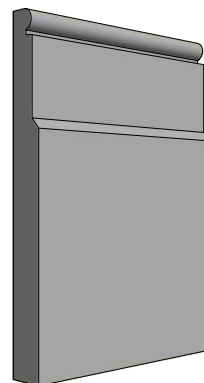
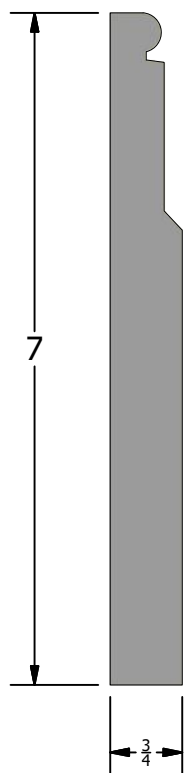

Base-06
Scale
1 / 2

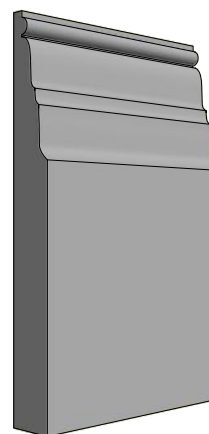
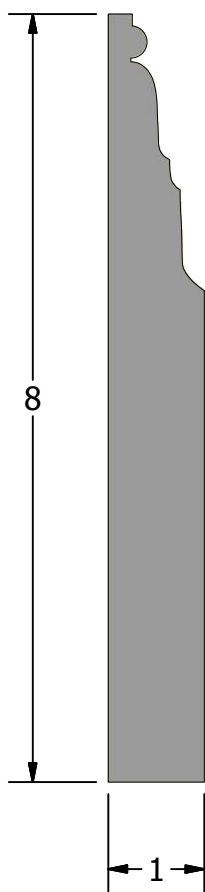

Base-07
Scale
1 / 2

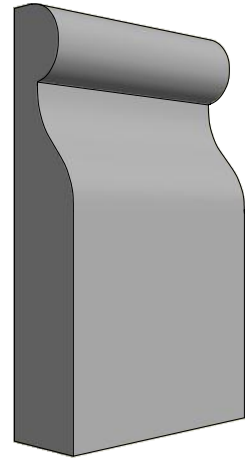
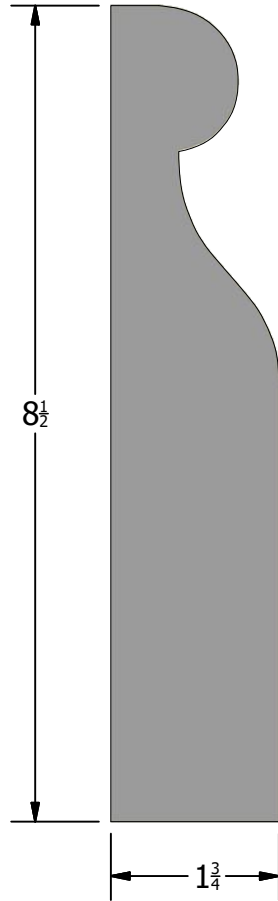

Base-08
Scale
1 / 2

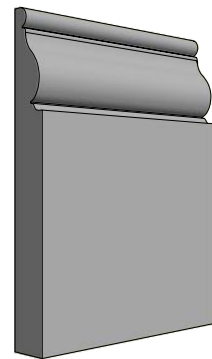
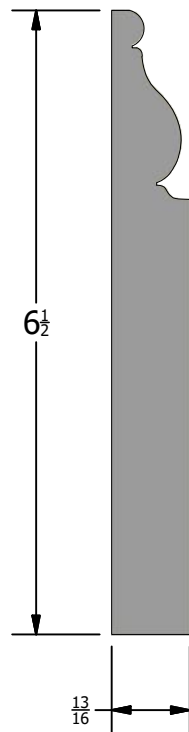

Base-09
Scale
1 / 2

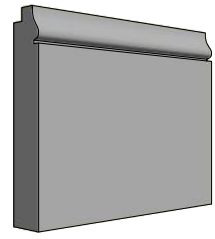
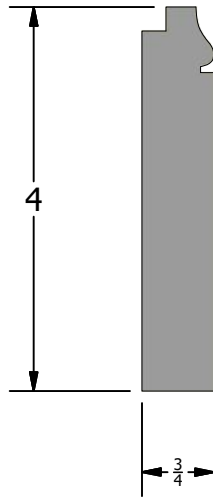

Base-10
Scale
1 / 2

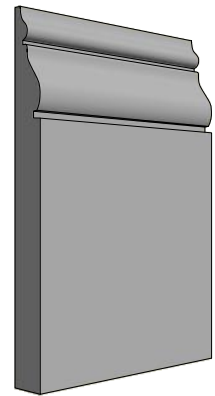
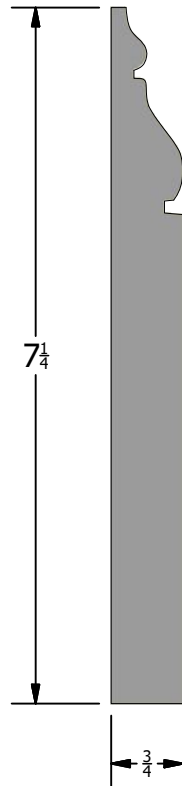

Base-11
Scale
1 / 2

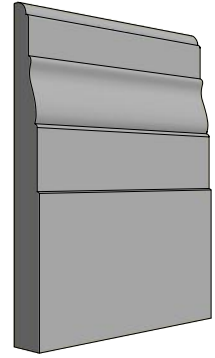
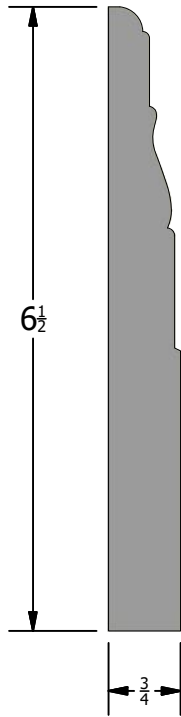

Base-12
Scale
1 / 2

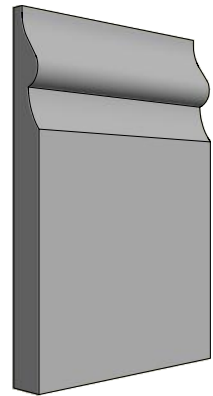
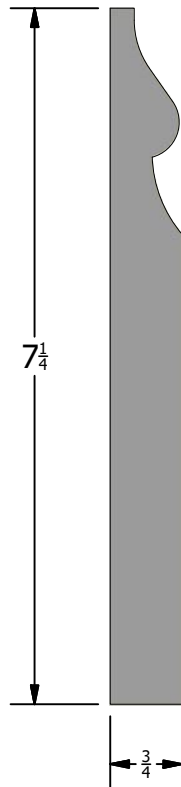

Base-13
Scale
1 / 2

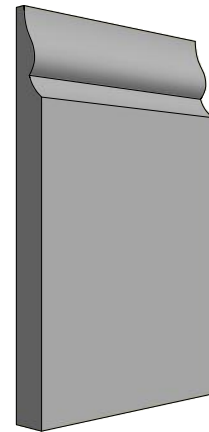
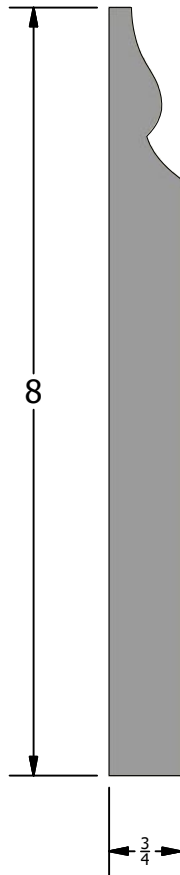

Base-14
Scale
1 / 2

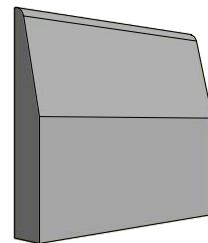
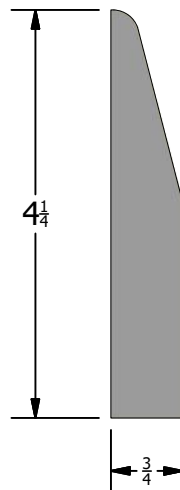

Base-15
Scale
1 / 2

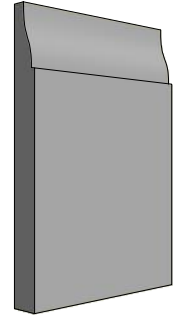
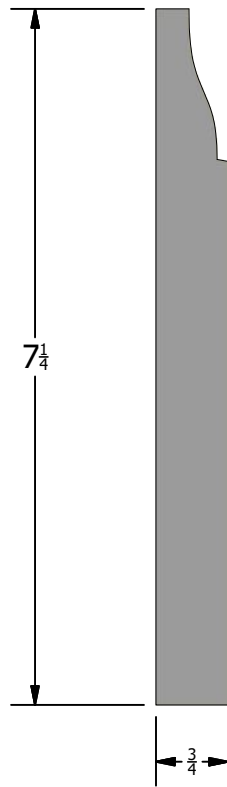

Base-16-A
Scale
1 / 2

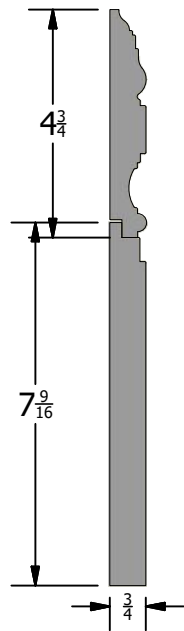

Base-16-B
Scale
1 / 2

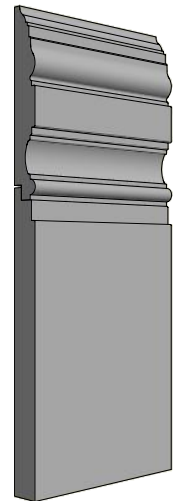

Crown Mould

- There are minimal modifications that can be made to crown moulding profiles.
- Dimensions and stock requirements are as indicated.

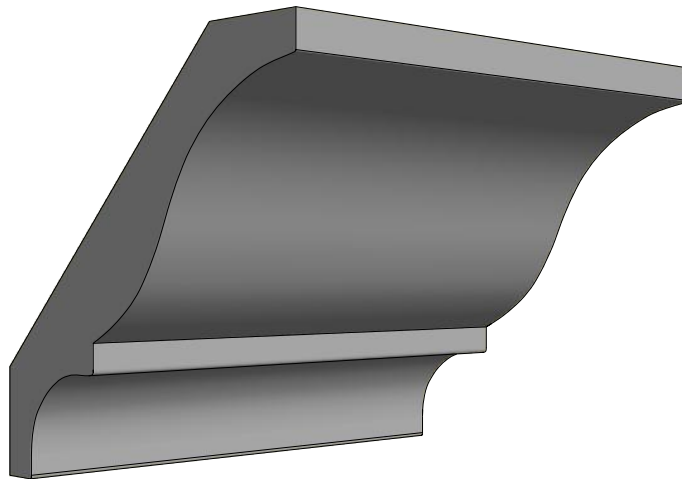

CRO-01

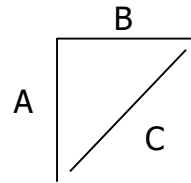
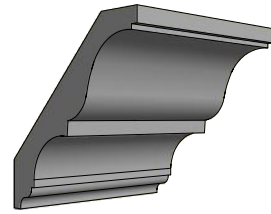
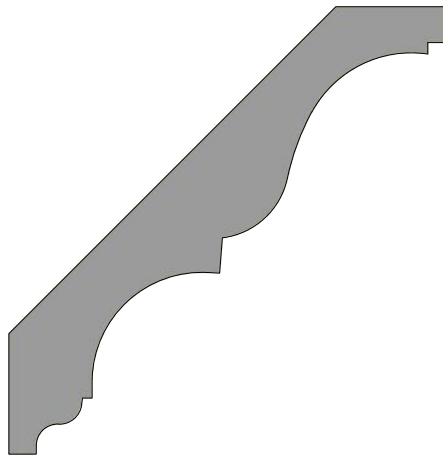

A: 4 1/2"
B: 4 1/2"
C: 6 3/8"

6/4

CRO-02

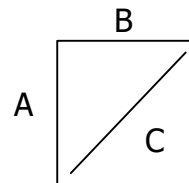
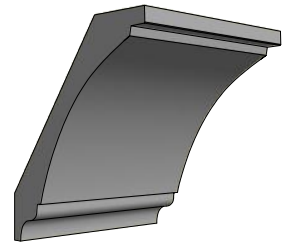
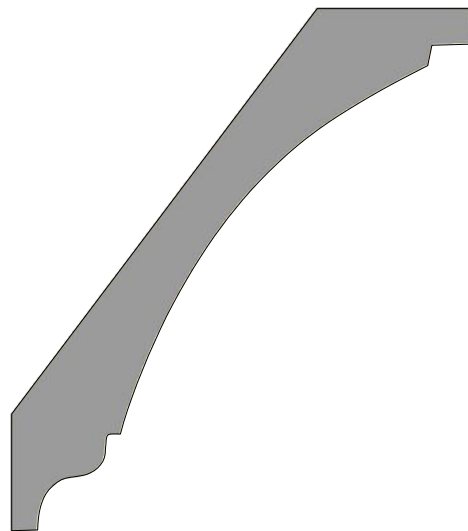

A: 5 7/16"
B: 4 13/16"
C: 7 1/4"

6/4

CRO-03

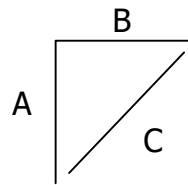
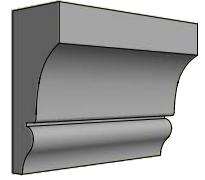
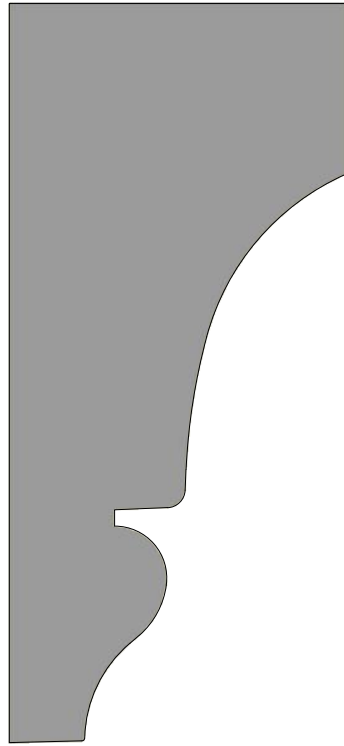

A: 3 5/8"
B: 2"
C: 4 1/8"

CRO-04

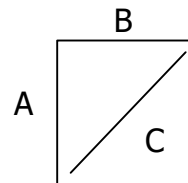
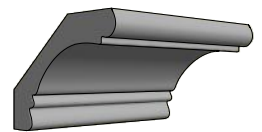
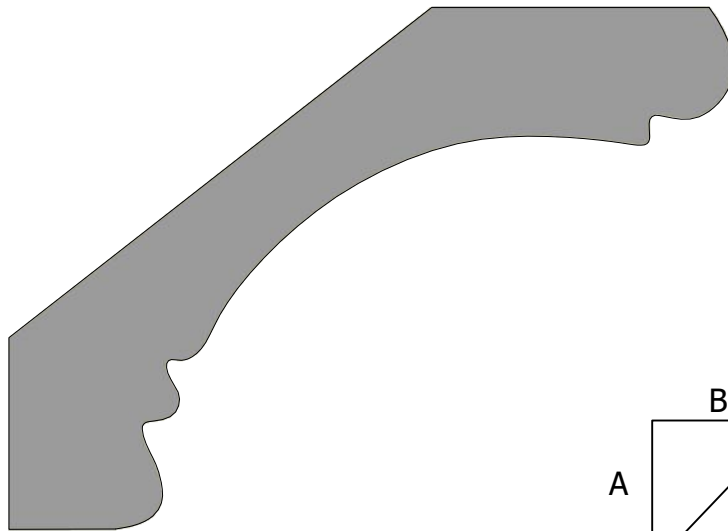

A: 2 11/16"
B: 3 5/8"
C: 4 9/16"

6/4

CRO-05

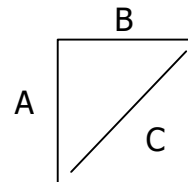
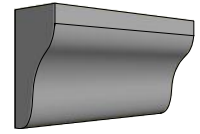
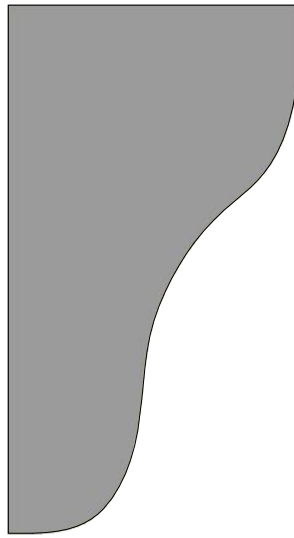

A: 2 3/4"
B: 1 1/2"
C: 3 1/8"

CRO-06

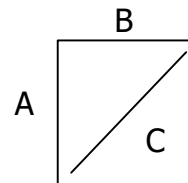
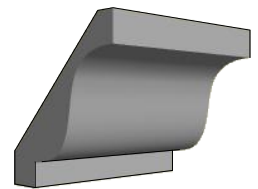
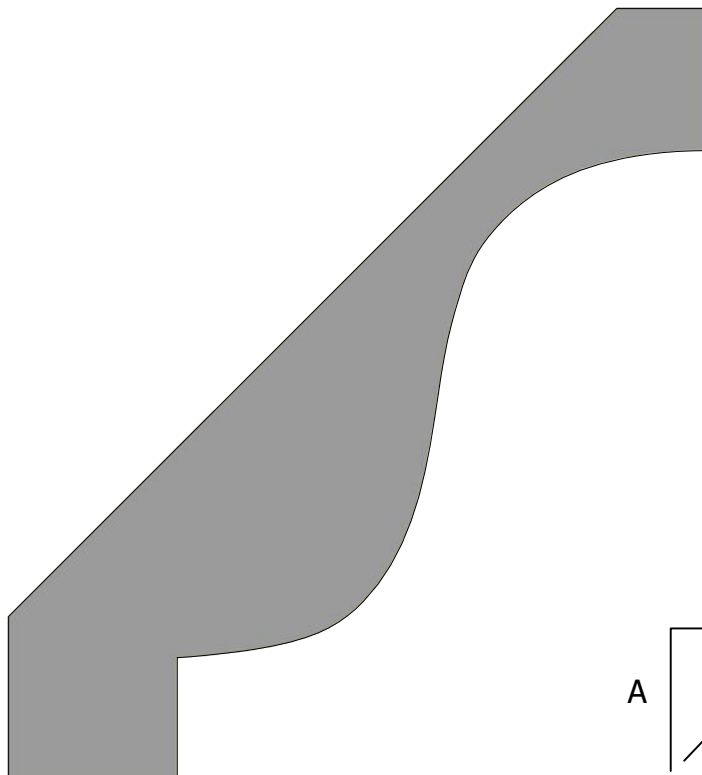

A: 4"
B: 3 5/8"
C: 5 7/16"

6/4

CRO-07

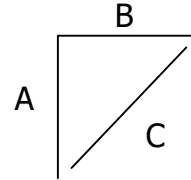
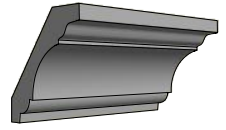
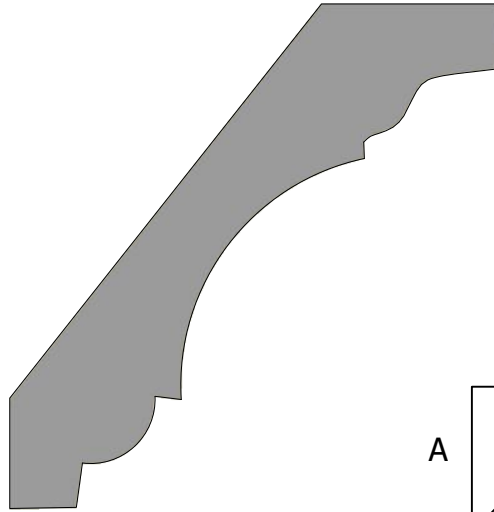

A: 2 5/8"
B: 2 9/16"
C: 3 5/8"

4/4

CRO-08

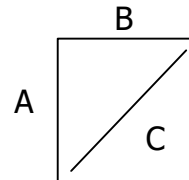
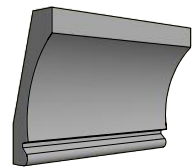
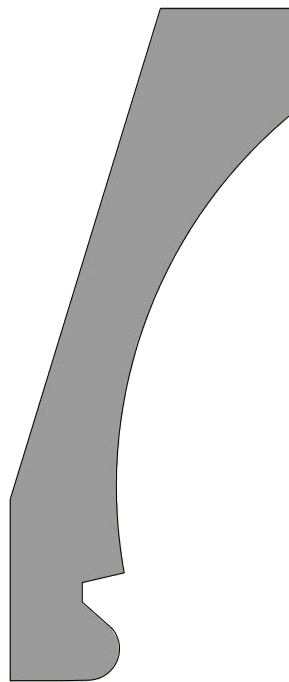

A: 3 1/2"
B: 1 7/16"
C: 3 13/16"

4/4

CRO-09

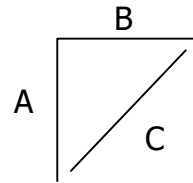
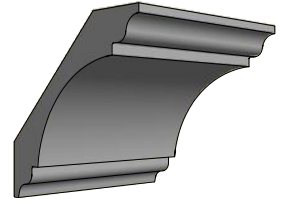
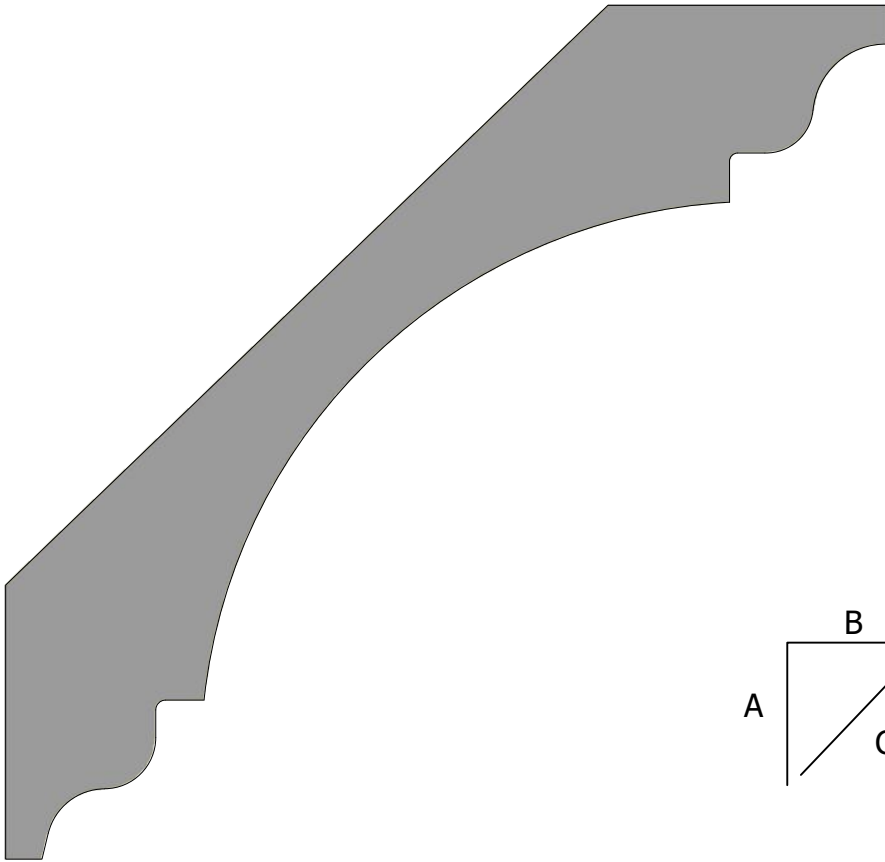

A: 4 7/16"
B: 4 9/16"
C: 6 3/8"

6/4

CRO-10

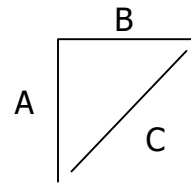
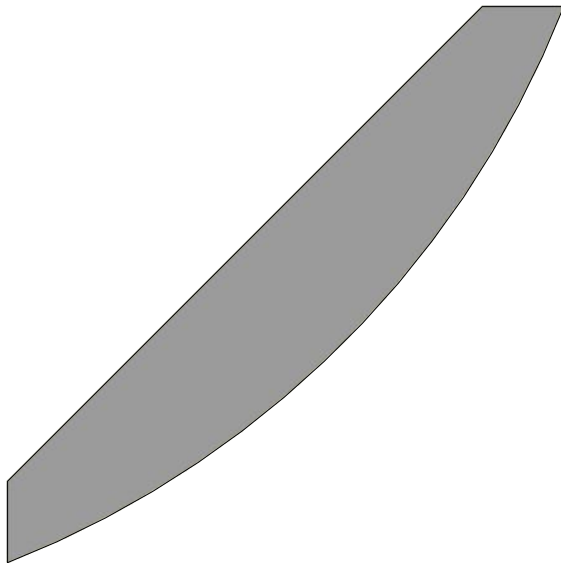

A: 2 7/8"
B: 2 7/8"
C: 4 1/8"

4/4

CRO-11

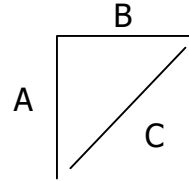
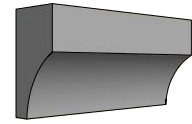
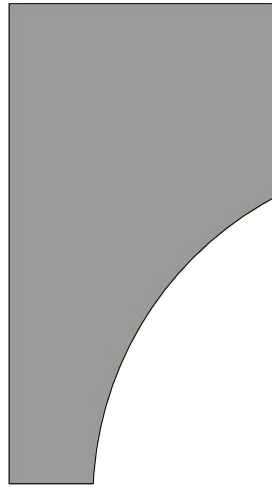

A: 2 1/2"
B: 1 3/8"
C: 2 7/8"

CRO-12-A

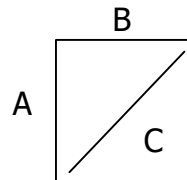
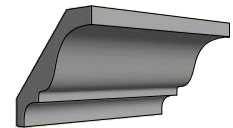
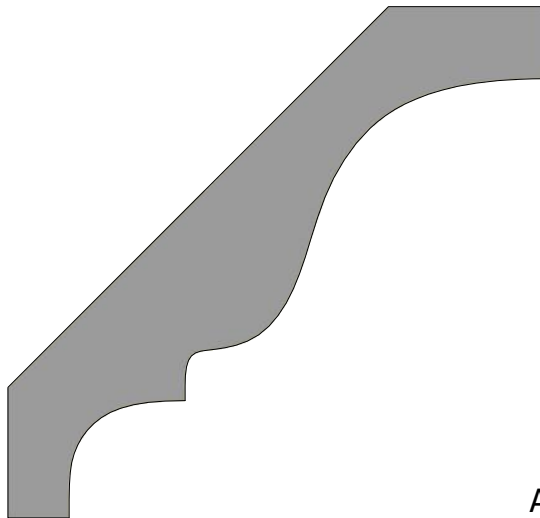

A: 2 11/16"
B: 2 13/16"
C: 3 7/8"

6/4

CRO-12-B

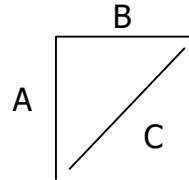
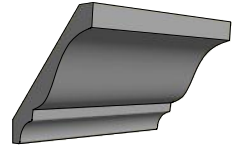
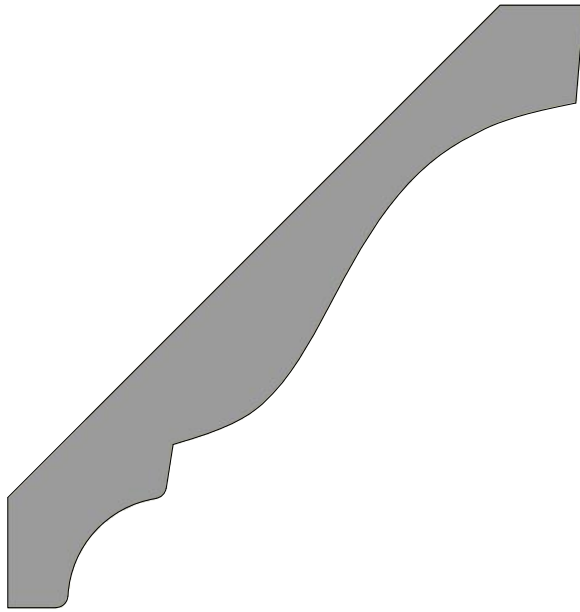

A: 3 1/8"
B: 3"
C: 4 5/16"

4/4

CRO-12-C

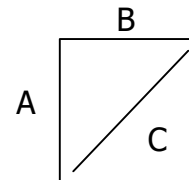
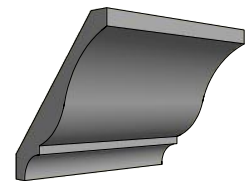
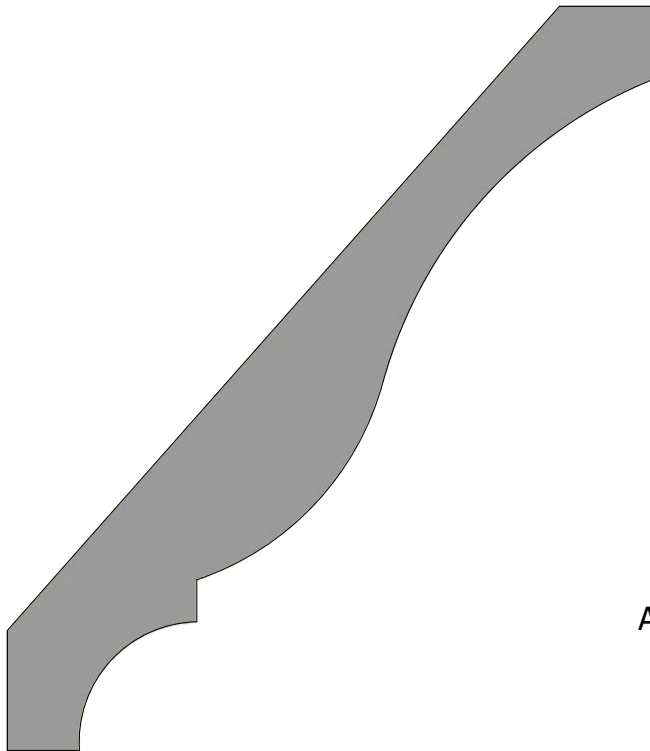

A: 3 7/8"
B: 3 3/8"
C: 5 1/8"

4/4

CRO-12-D

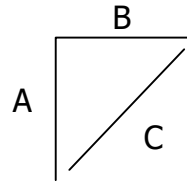
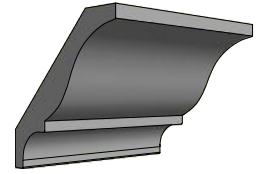
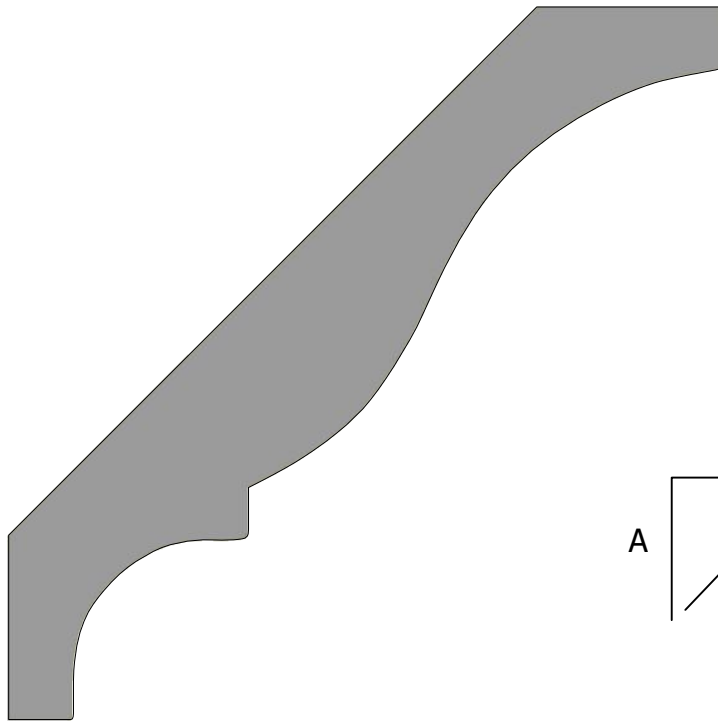

A: 3 11/16"
B: 3 3/4"
C: 5 1/4"

4/4

CRO-12-E

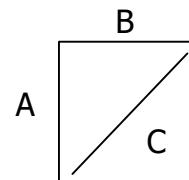
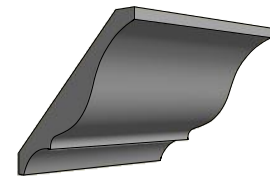
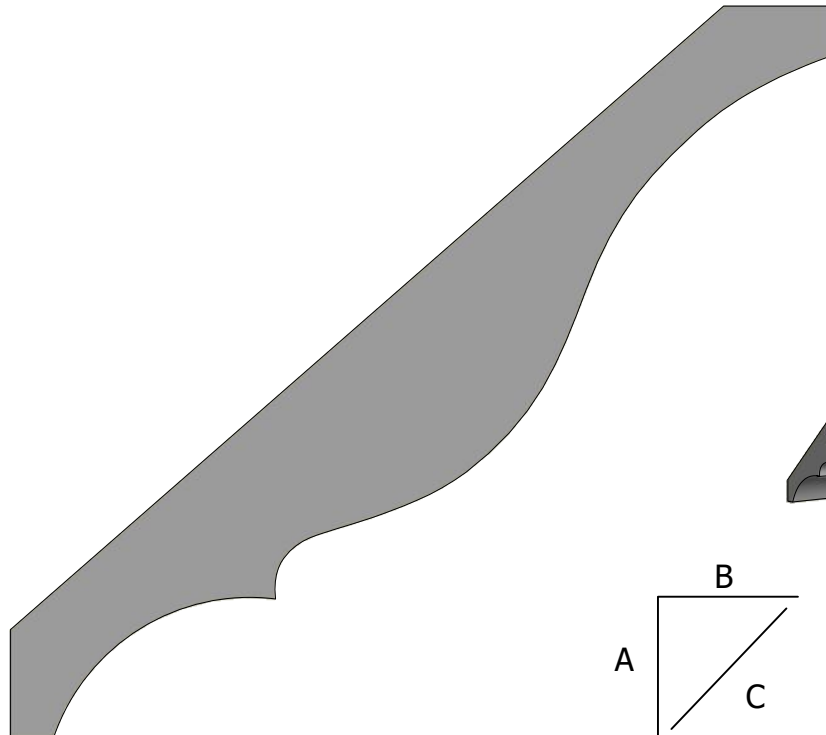

A: 3 13/16"
B: 4 1/4"
C: 5 3/4"

4/4

CRO-12-F

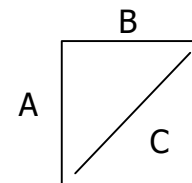
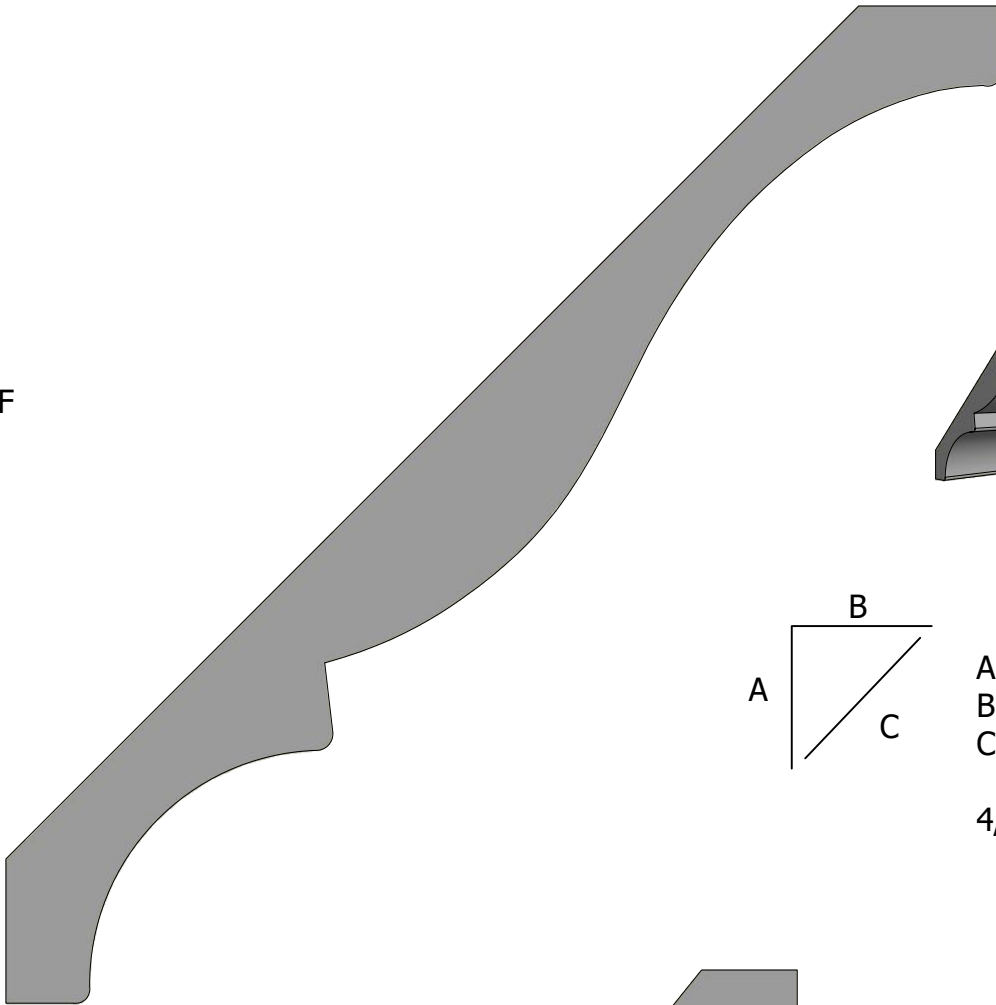

A: 5 3/16"
B: 5 3/16"
C: 7 5/16"

4/4

CRO-12-G

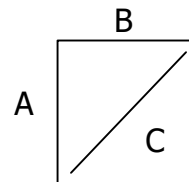
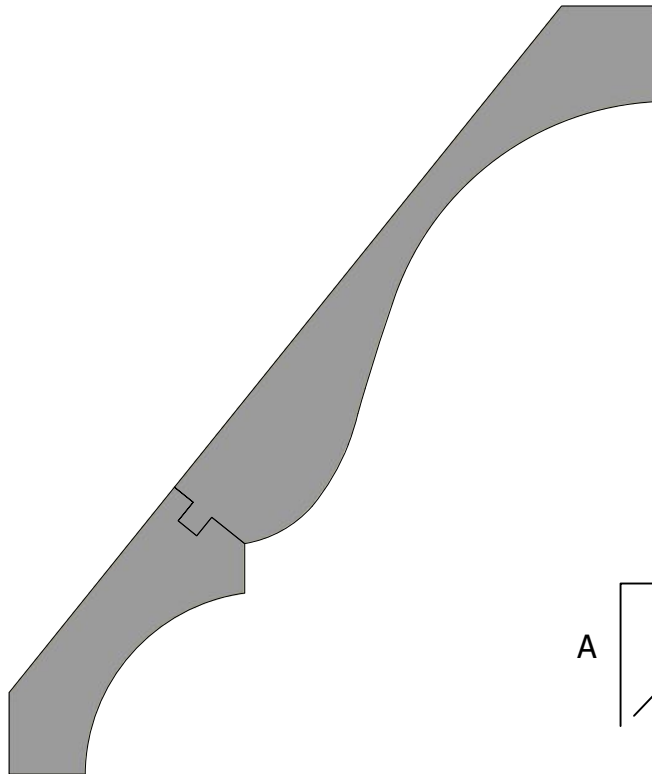

A: 8"
B: 6 3/4"
C: 10 7/16"

4/4



CRO-13

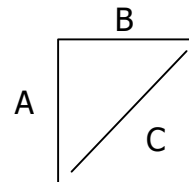
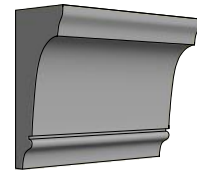
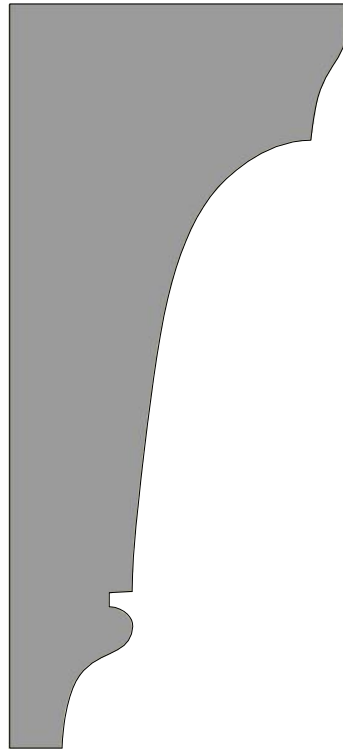

A: 3 7/8"
B: 1 3/4"
C: 4 1/4"

CRO-14

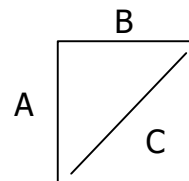
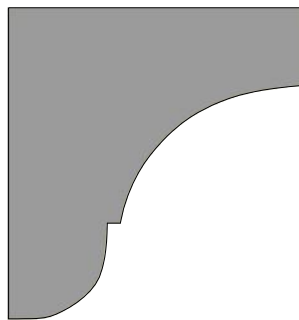

A: 1 5/8"
B: 1 1/2"
C: 2 1/4"

CRO-15

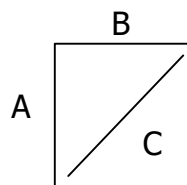
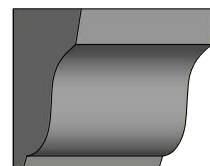
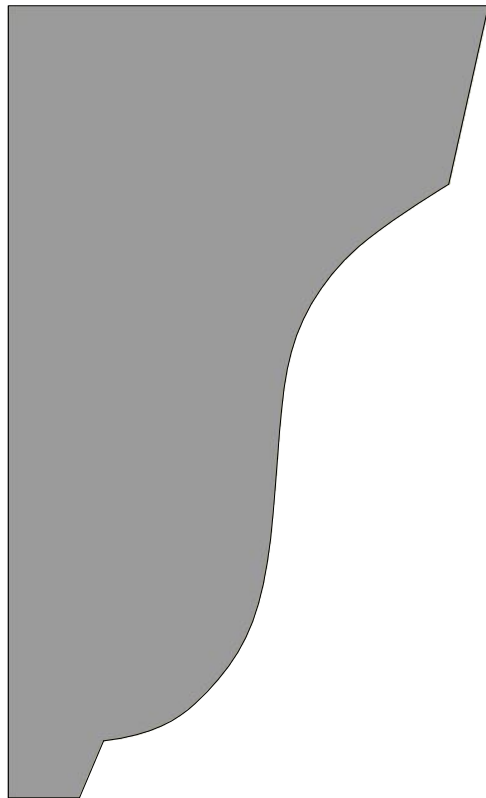

A: 4 1/8"
B: 2 1/2"
C: 4 13/16"

CRO-16

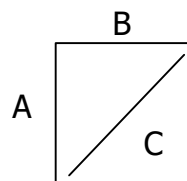
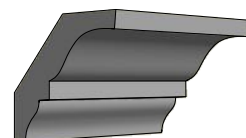
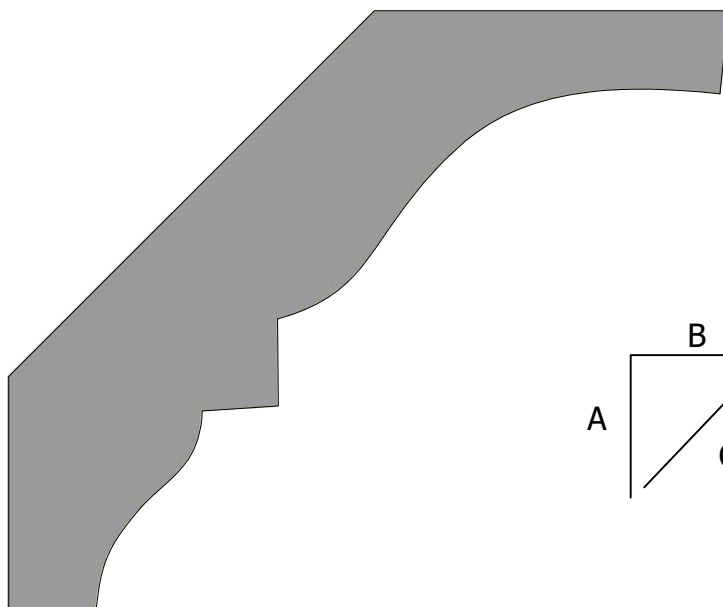

A: 3 1/8"
B: 3 3/4"
C: 4 7/8"

8/4

CRO-17-A

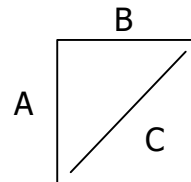
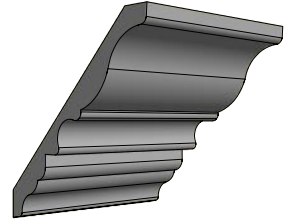
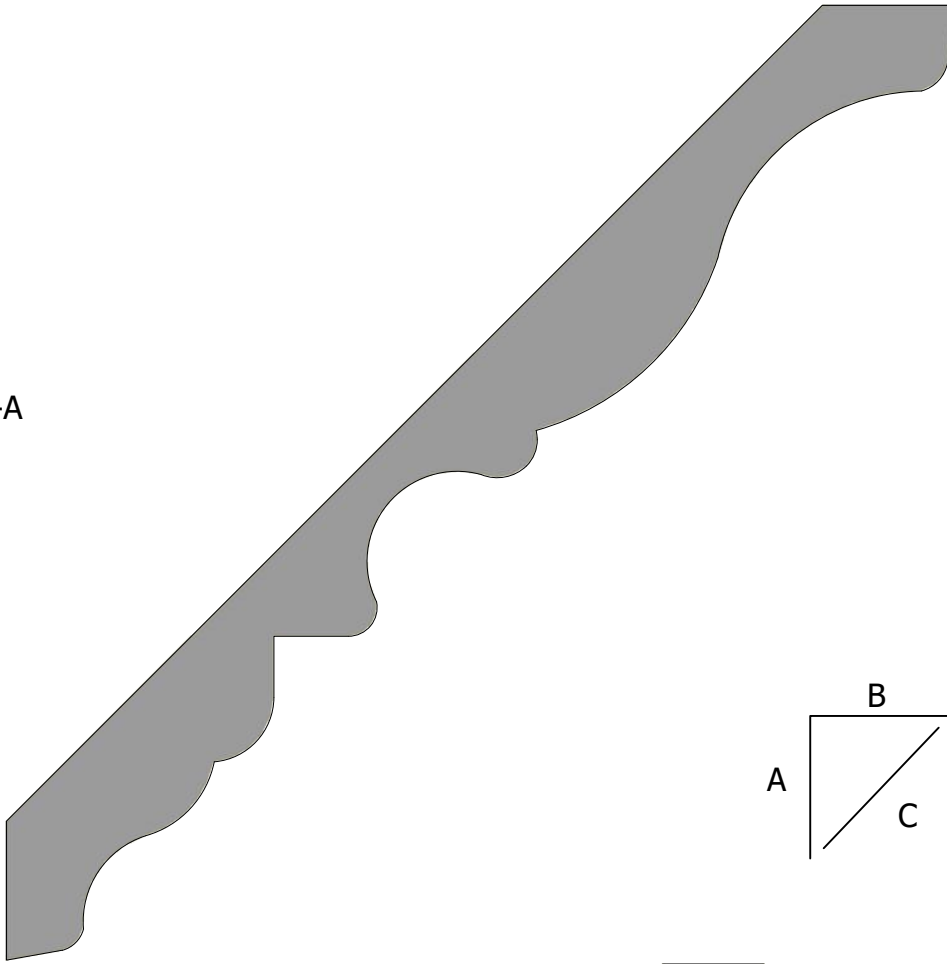

A: 5"
B: 4 15/16"
C: 7"

4/4

CRO-17-B

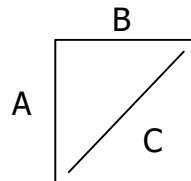
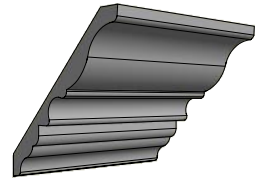
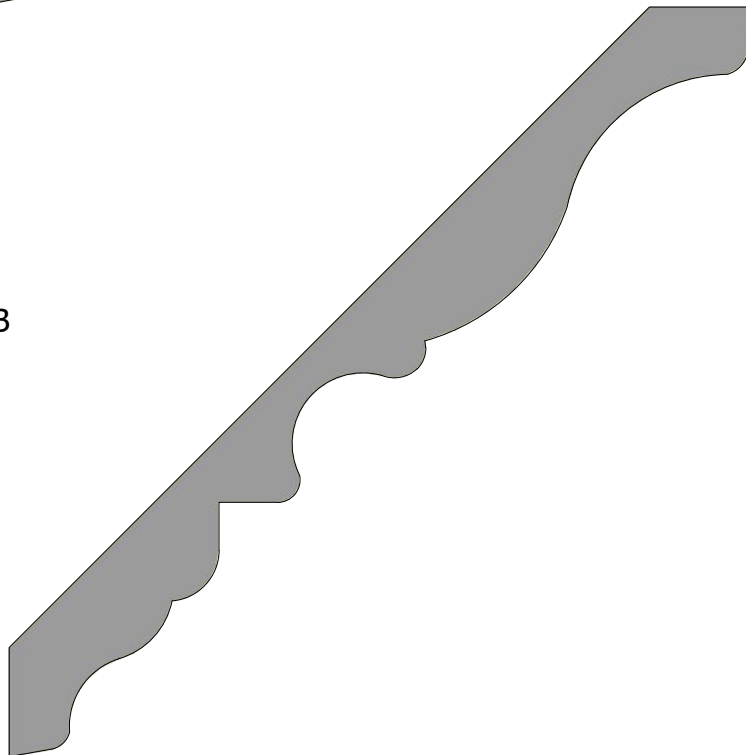

A: 3 7/8"
B: 3 7/8"
C: 5 1/2"

4/4

CRO-18

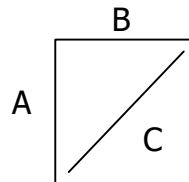
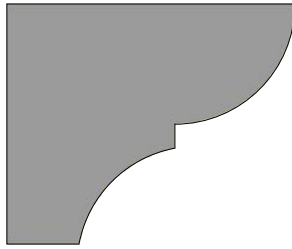

A: 1 1/4"
B: 1 1/2"
C: 1 15/16"

CRO-19

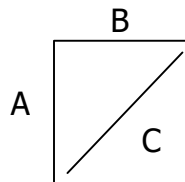
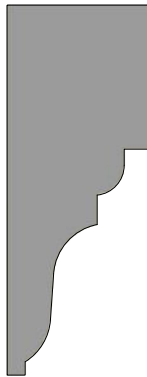

A: 1 15/16"
B: 3/4"
C: 2 1/16"

CRO-20-A

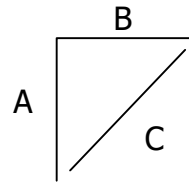
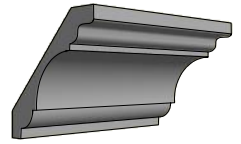
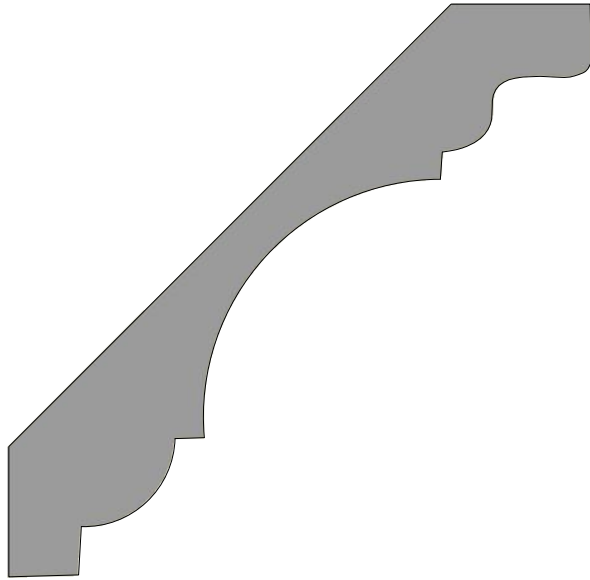

A: 3"
B: 3"
C: 4 1/4"
4/4

CRO-20-B

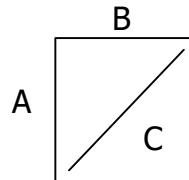
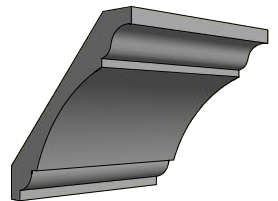
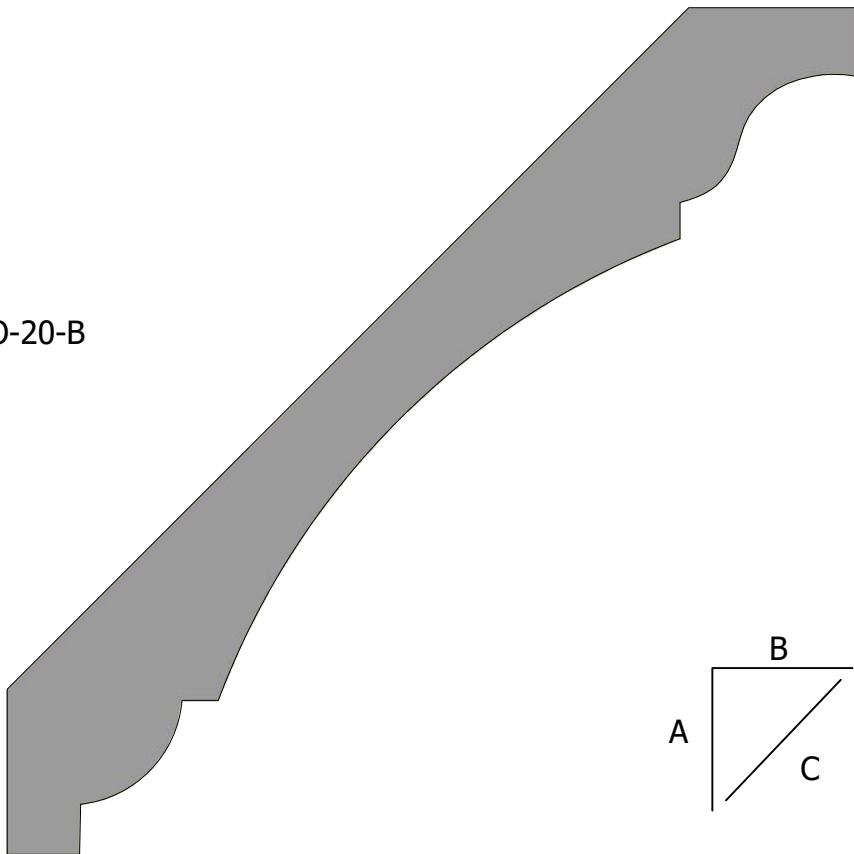

A: 4 7/16"
B: 4 7/16"
C: 6 1/4"
4/4

CRO-21

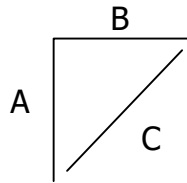
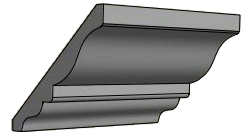
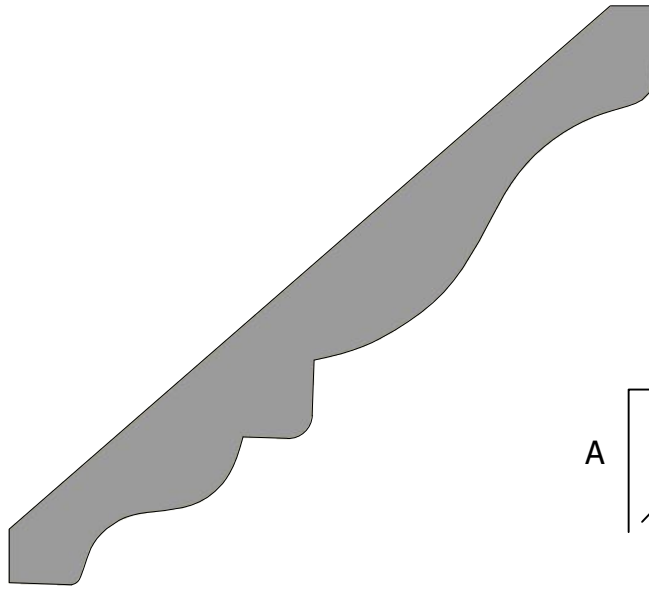

A: 3"
B: 3 3/8"
C: 4 1/2"
4/4

CRO-22

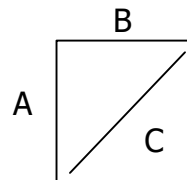
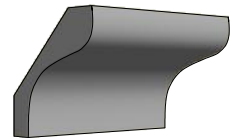
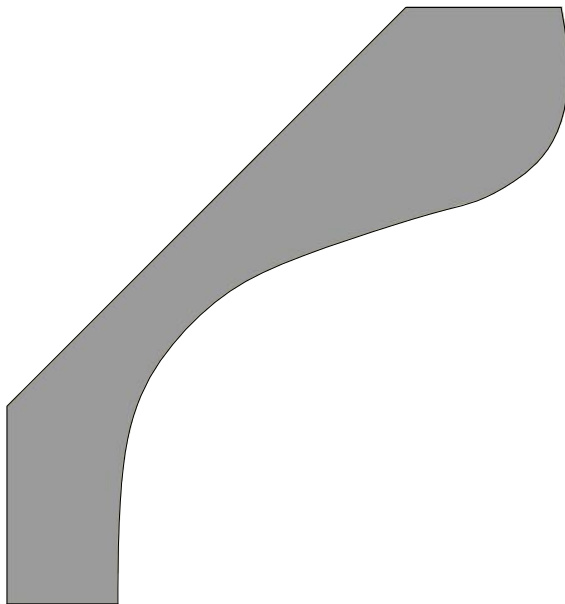

A: 3 1/8"
B: 2 7/8"
C: 4 1/4"
6/4

CRO-23

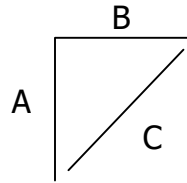
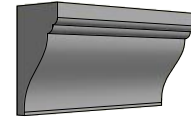
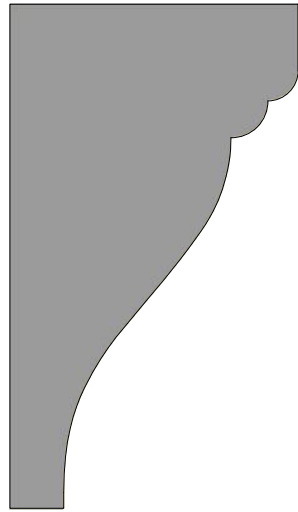

A: 2 5/8"
B: 1 1/2"
C: 3"

CRO-24

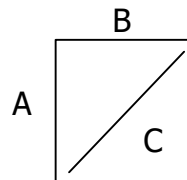
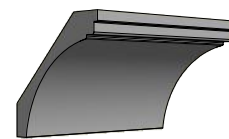
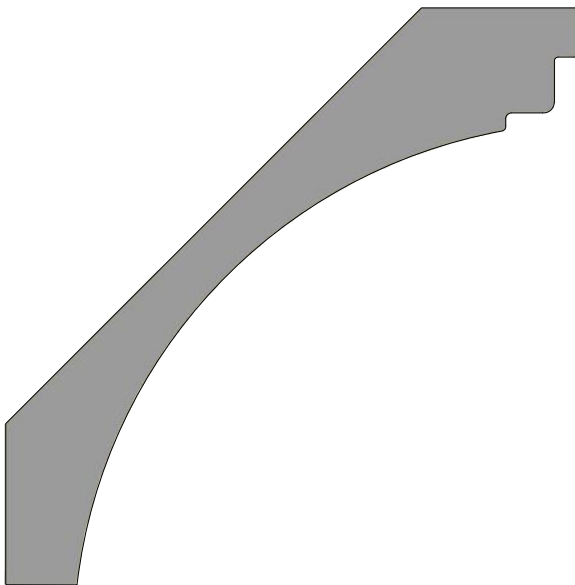

A: 3"
B: 3"
C: 4 1/4"

4/4

CRO-25

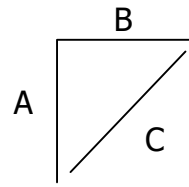
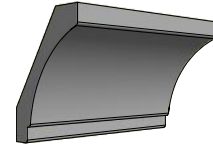
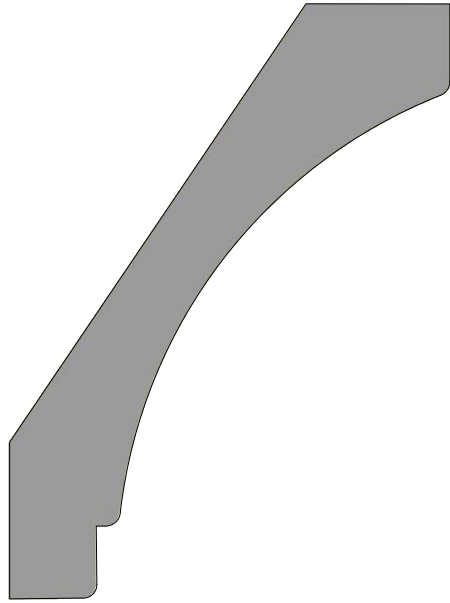

A: 2 5/16"

B: 3 1/8"

C: 3 7/8"

4/4

CRO-26

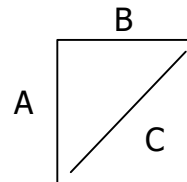
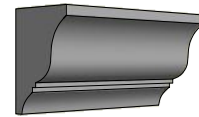
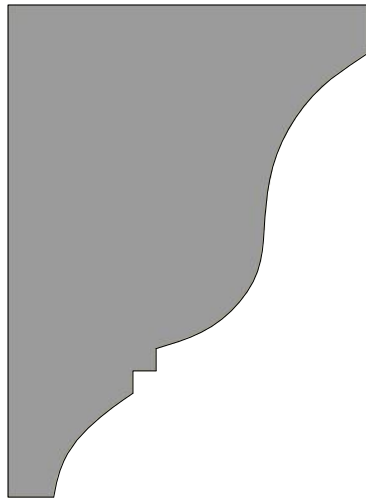

A: 2 9/16"

B: 1 7/8"

C: 3 3/16"

CRO-27

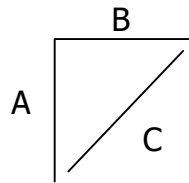
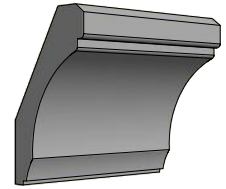
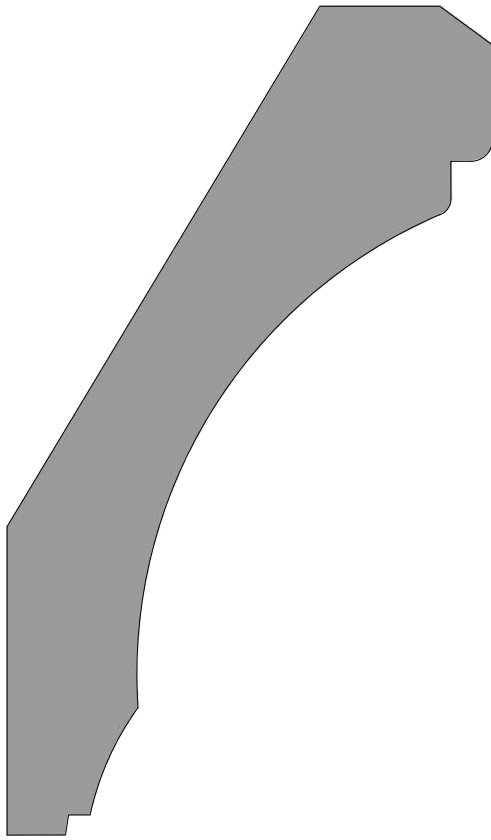

A: $4 \frac{15}{16}$ "
B: $2 \frac{1}{2}$ "
C: $4 \frac{13}{16}$ "

$\frac{6}{4}$

CRO-28

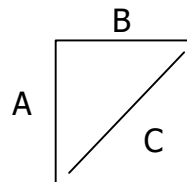
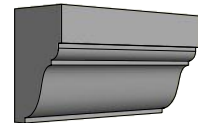
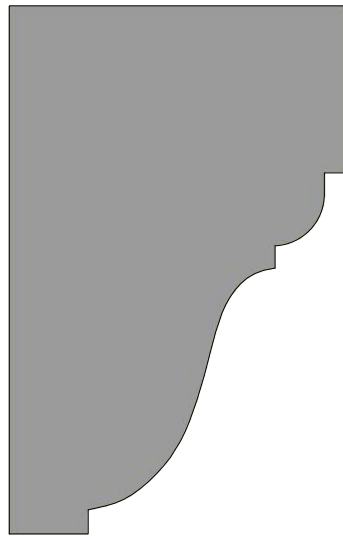

A: $2 \frac{3}{4}$ "
B: $1 \frac{3}{4}$ "
C: $3 \frac{1}{4}$ "

CRO-29

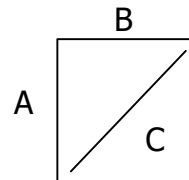
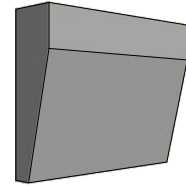
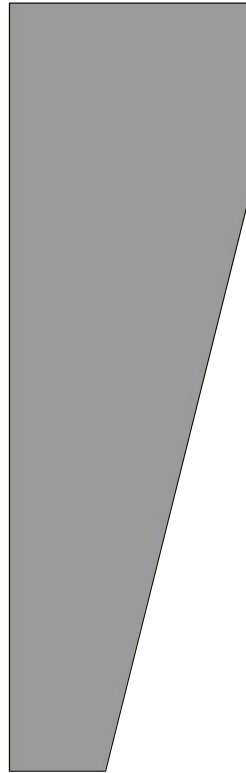

A: 4"
B: 1 3/4"
C: 4 13/16"

CRO-30

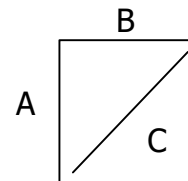
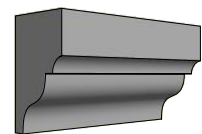
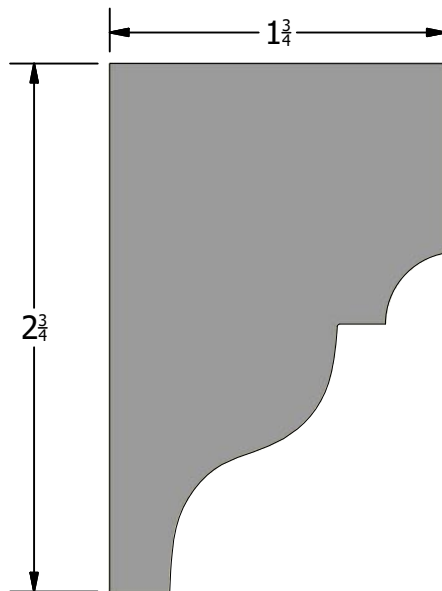

A: 2 3/4"
B: 1 3/4"
C: 3 1/4"

CRO-31

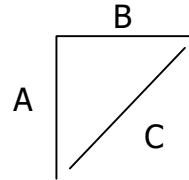
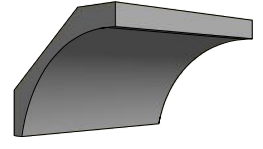
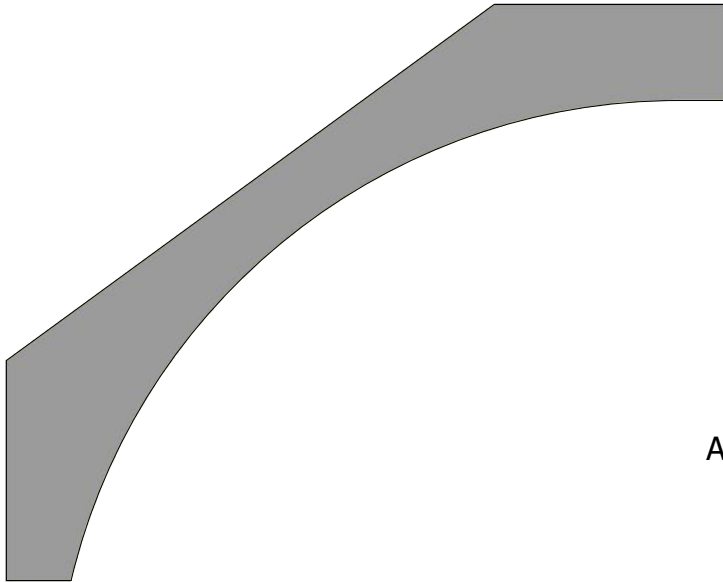

A: 3 "
B: 3 3/4"
C: 4 13/16"

6/4

CRO-32

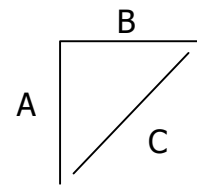
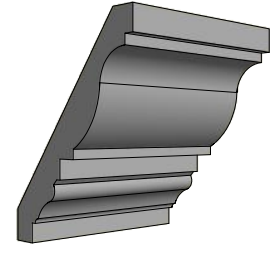

A: 5 1/2"
B: 4 1/4"
C: 6 15/16"

4/4

CRO-33

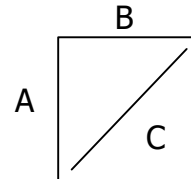
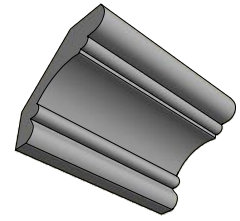
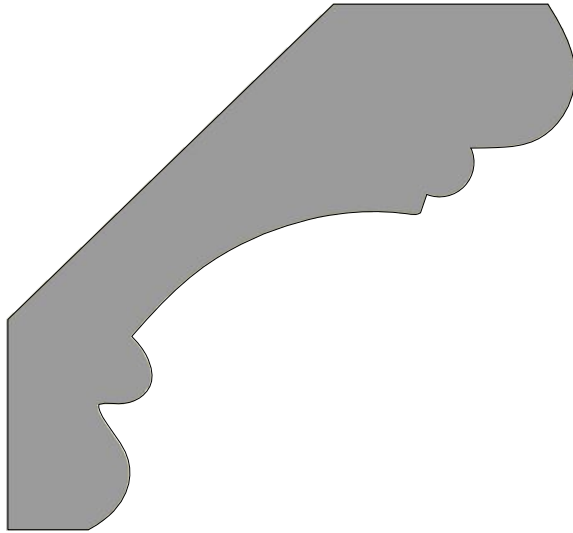

A: $2 \frac{3}{4}$ "
B: $2 \frac{13}{16}$ "
C: $3 \frac{15}{16}$ "

$\frac{6}{4}$

CRO-34

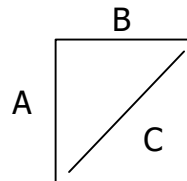
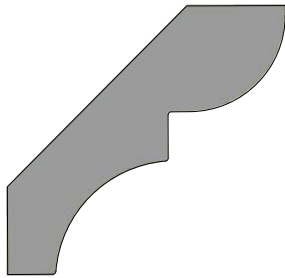

A: $1 \frac{3}{8}$ "
B: $1 \frac{7}{16}$ "
C: 2"

$\frac{4}{4}$

Panel Mould

- Most panel moulds can be modified for depth or width.
- Some can have a rabbet added to receive a panel or style.

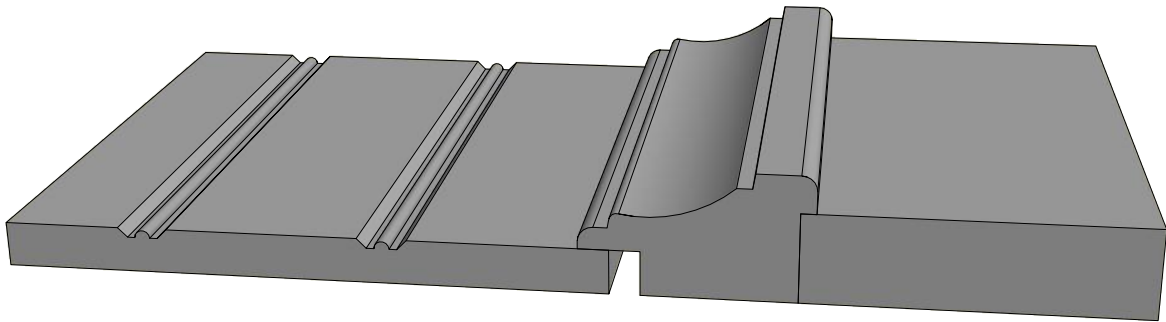

Pan-01

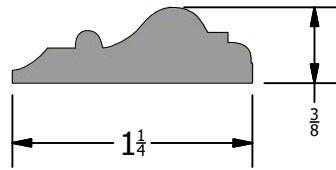

Pan-02

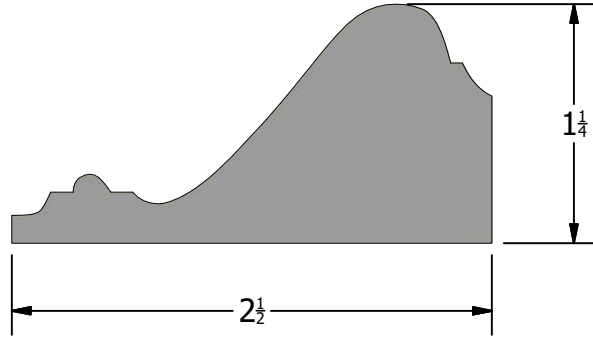

Pan-03

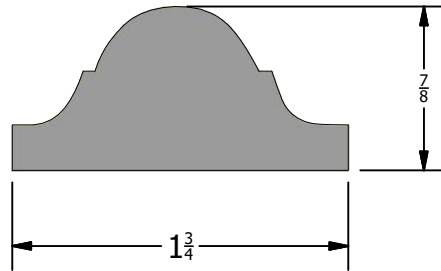

Pan-04

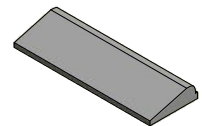
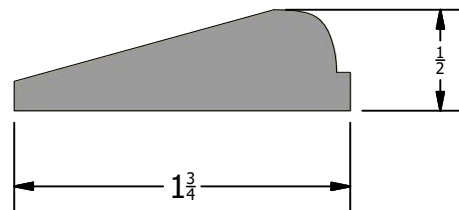

Pan-05

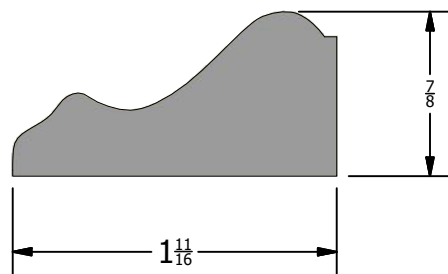

Pan-06

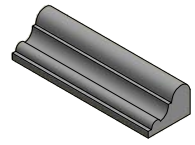
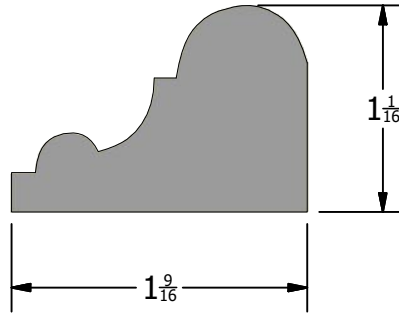

Pan-07

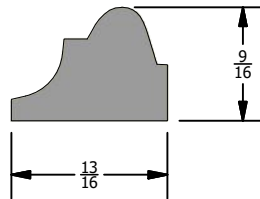

Pan-08

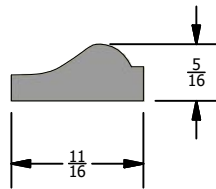

Pan-09

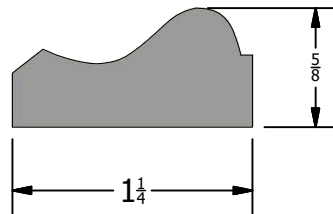

Pan-10

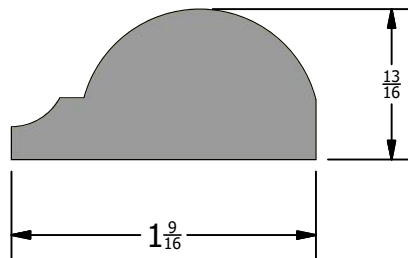

Pan-11

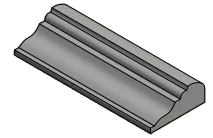
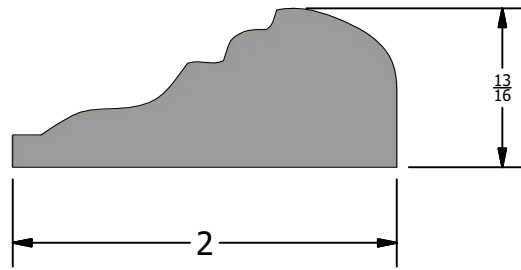

Pan-12

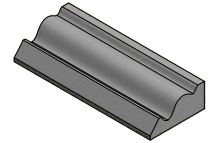
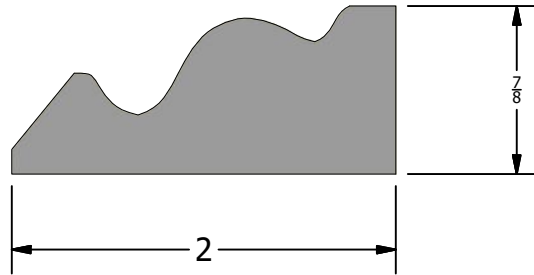

Pan-13

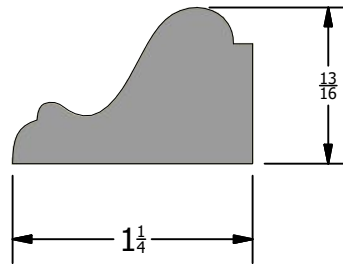

Pan-14

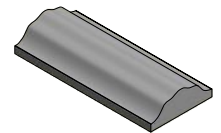
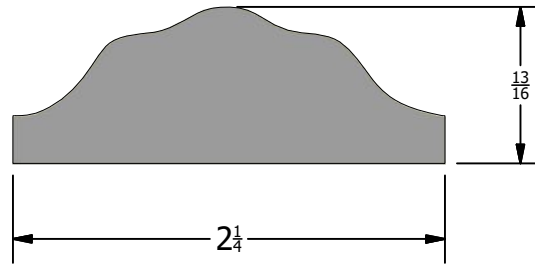

Pan-15

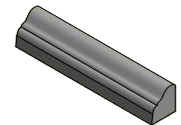
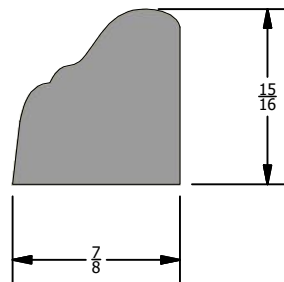

Pan-16

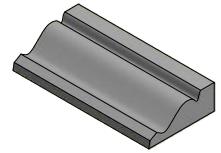
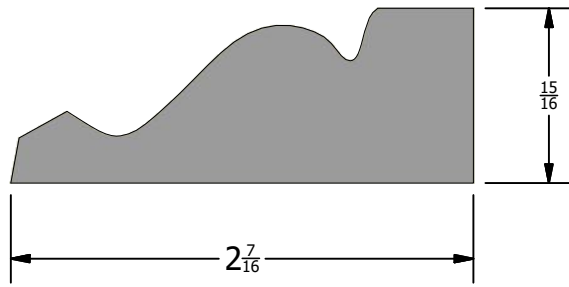

Pan-17

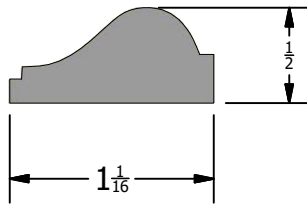

Pan-18

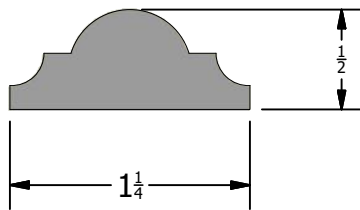

Pan-19

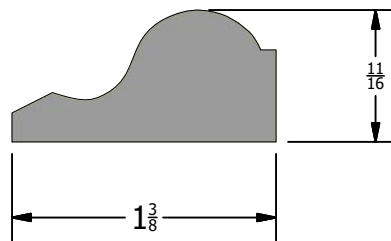

Pan-20

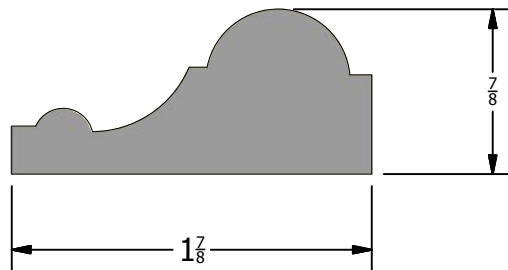

Pan-21

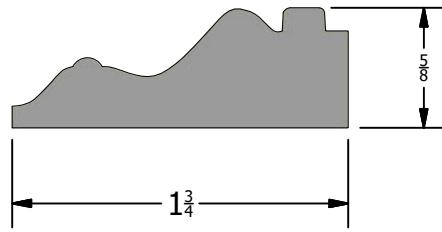

Pan-22

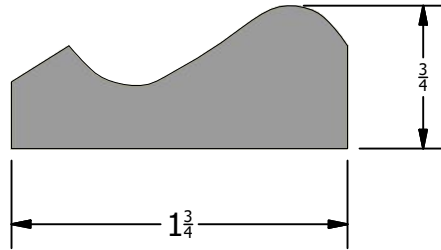

Pan-23

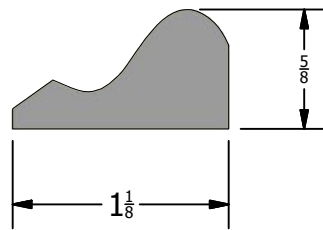

Pan-24

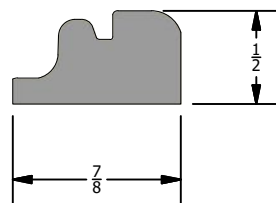

Pan-25

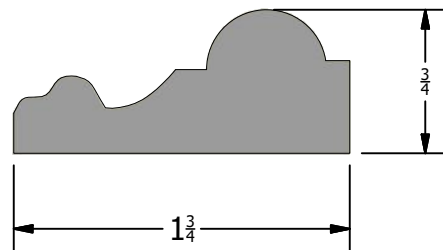

Pan-26

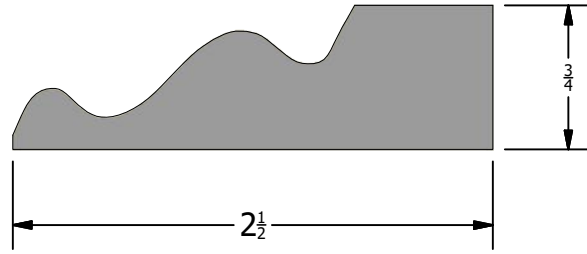

Pan-27

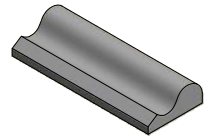
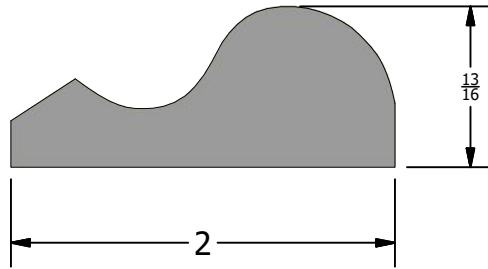

Pan-28

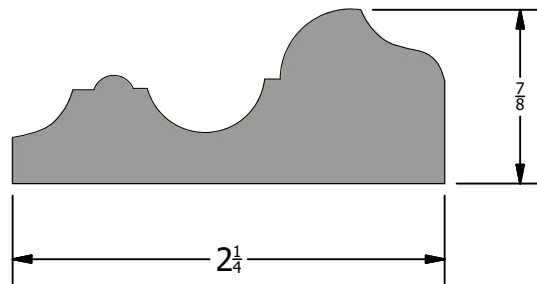

Pan-29

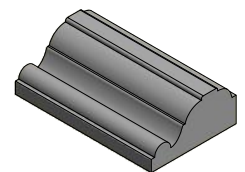
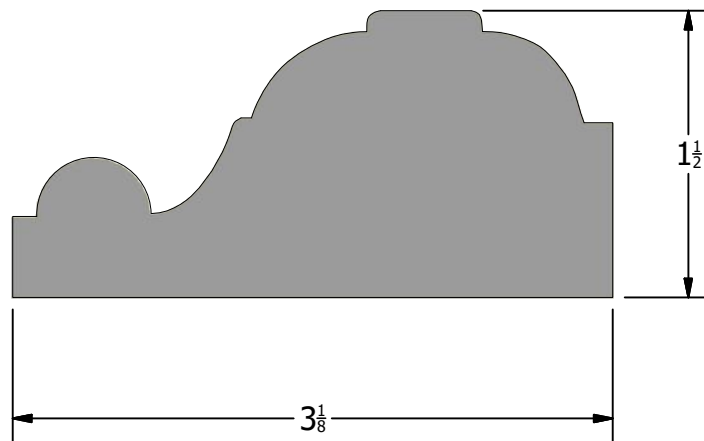

Pan-30

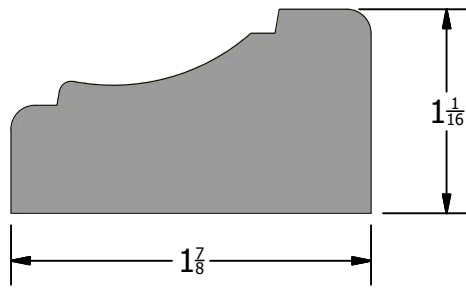

Pan-31

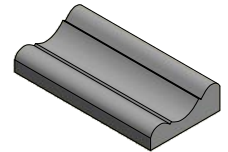
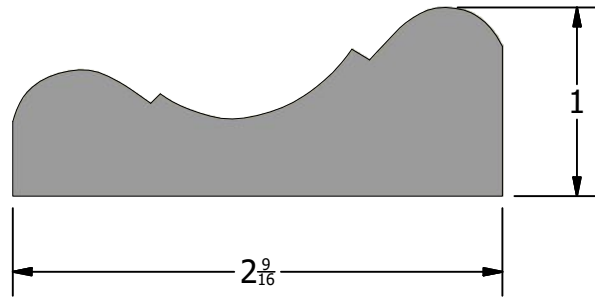

Pan-32

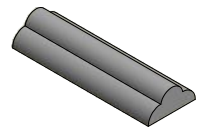
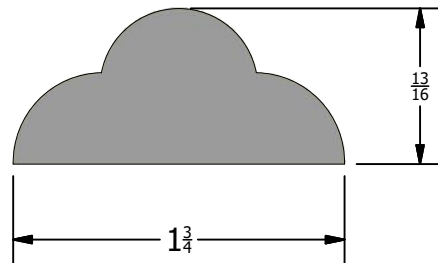

Pan-33

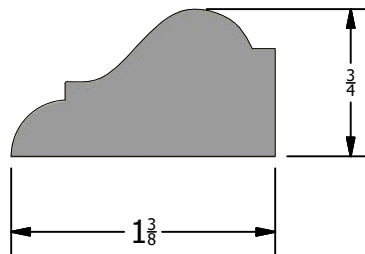

Pan-34

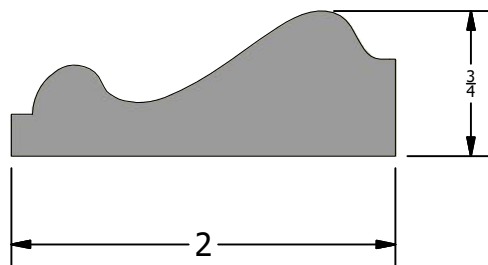

Pan-35

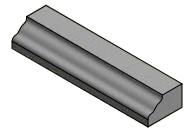
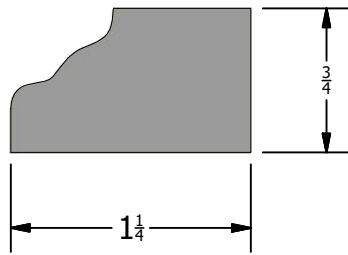

Pan-36-A

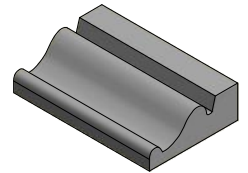
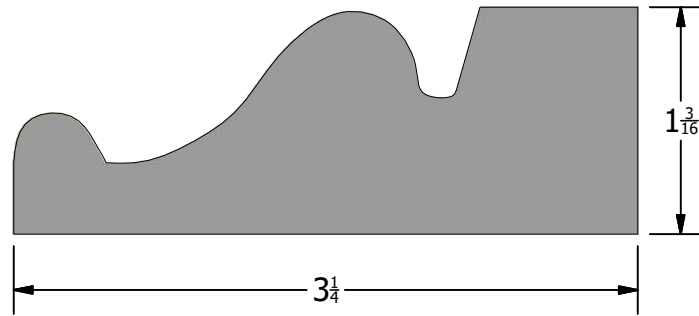

Pan-36-B

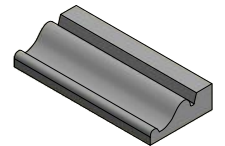
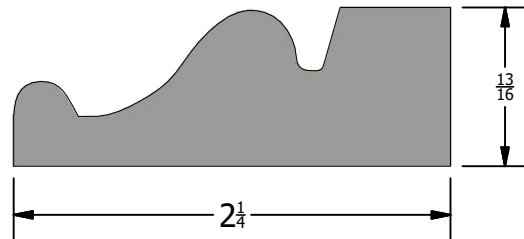

Pan-37

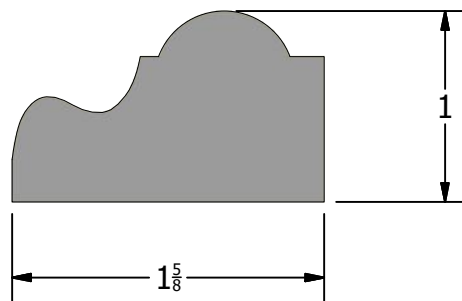

Pan-38

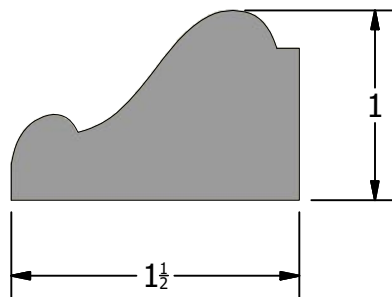

Pan-39

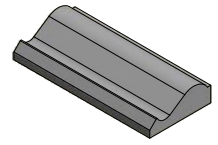
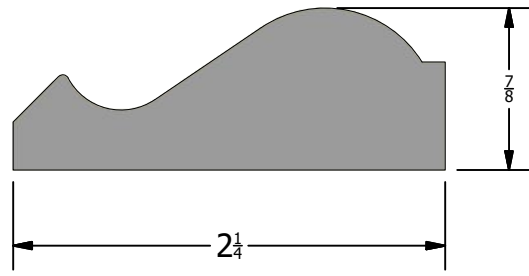

Pan-40

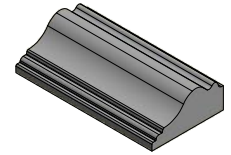
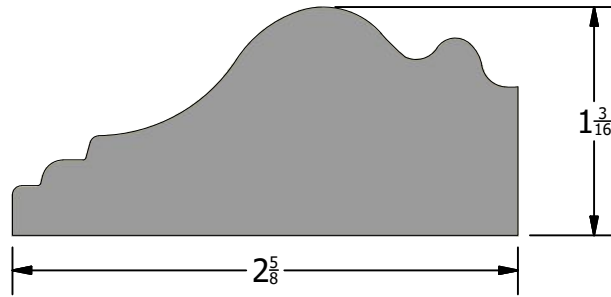

Pan-41

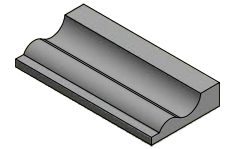
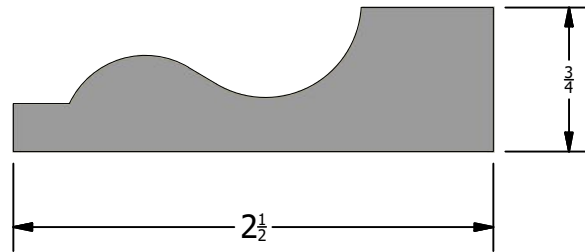

Pan-42

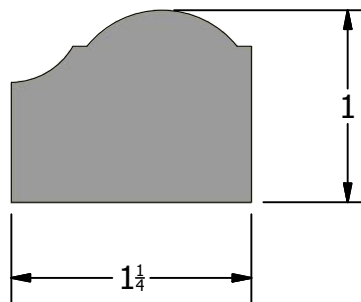

Pan-43

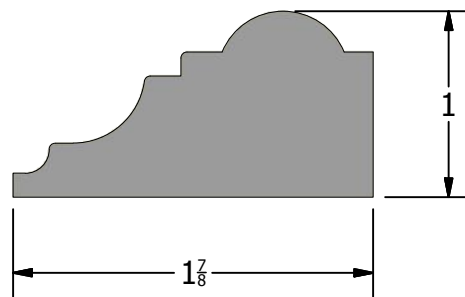

Pan-44

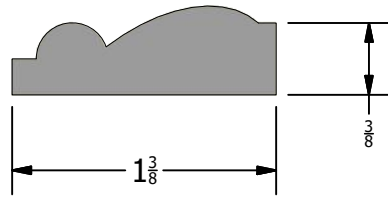

Pan-45

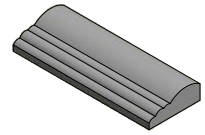
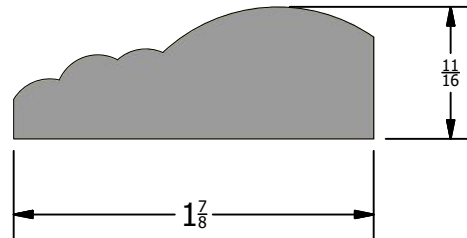

Pan-46

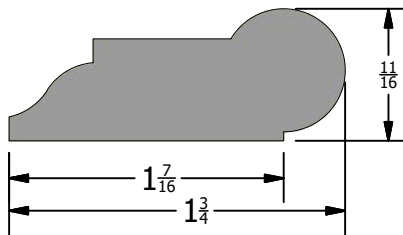

Pan-47-A

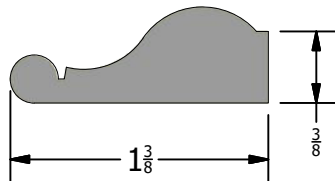

Pan-47-B

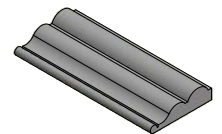
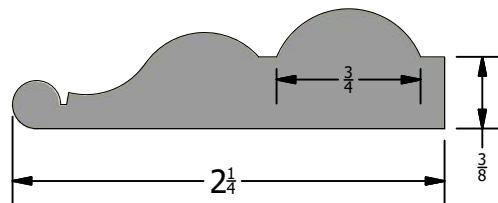

Pan-48

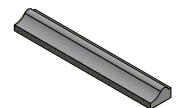
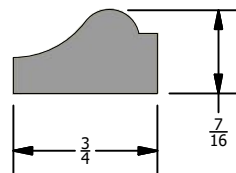

Pan-49-A

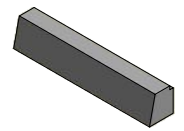
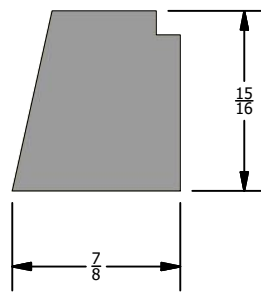

Pan-49-B

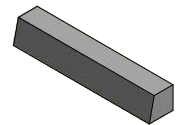
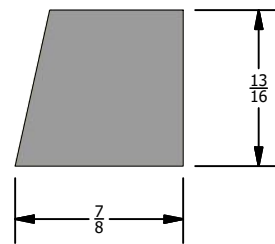

Pan-50

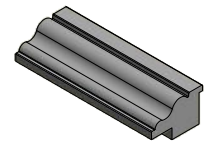
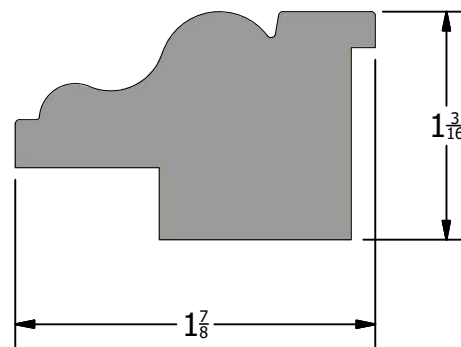

Pan-51

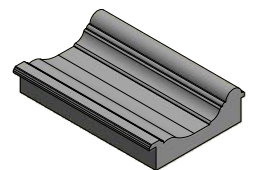
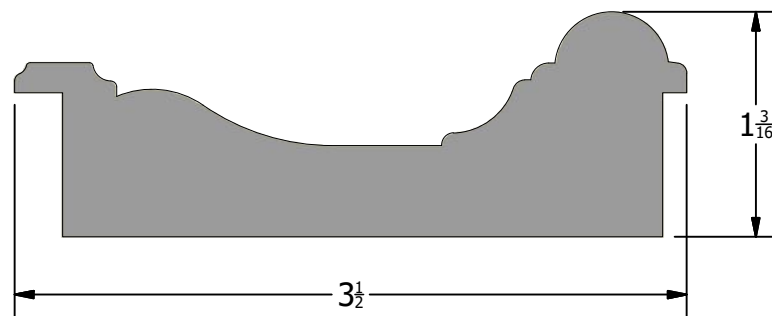

Pan-52

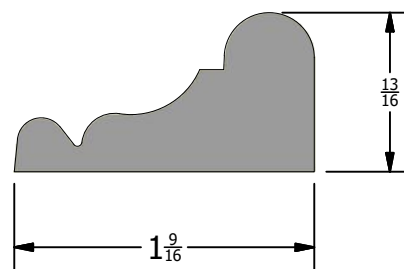

Pan-53

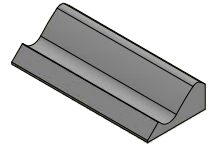
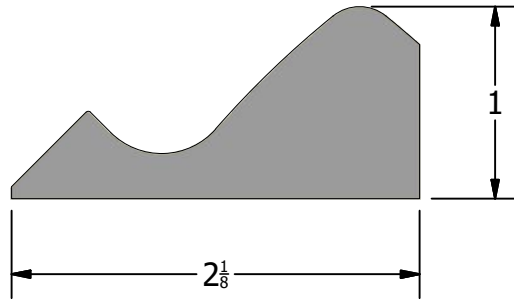

Pan-54

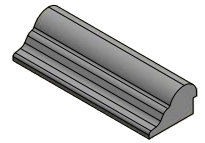
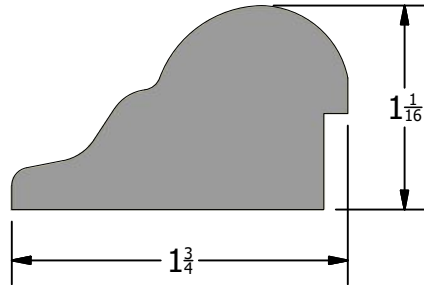

Pan-55

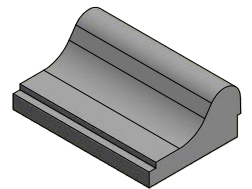
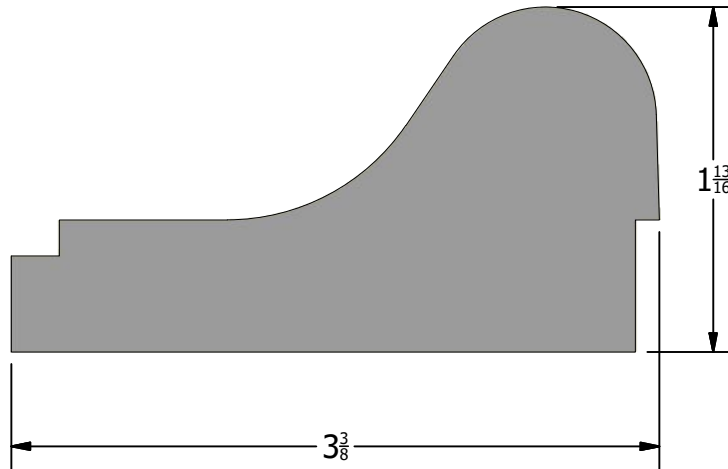

Pan-56

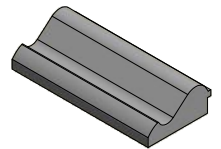
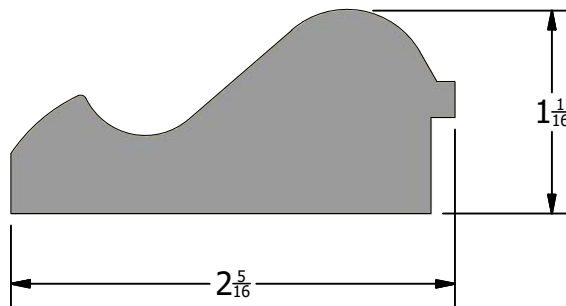

Pan-57

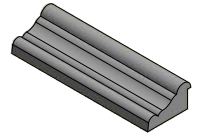
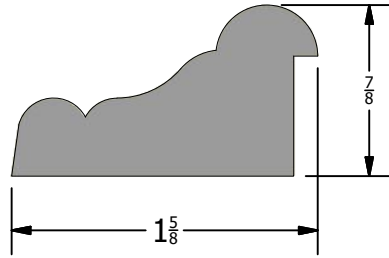

Pan-58

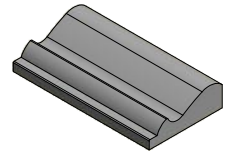
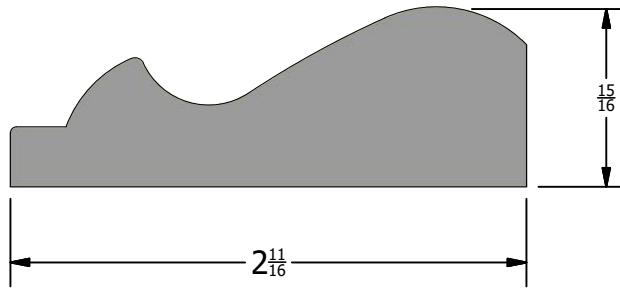

Pan-59

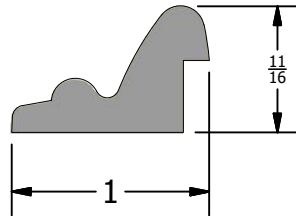

Pan-60

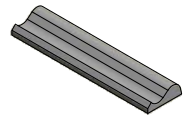
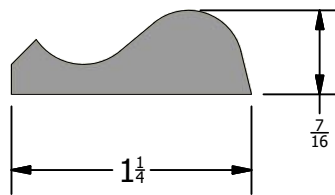

Pan-61

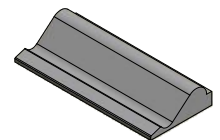
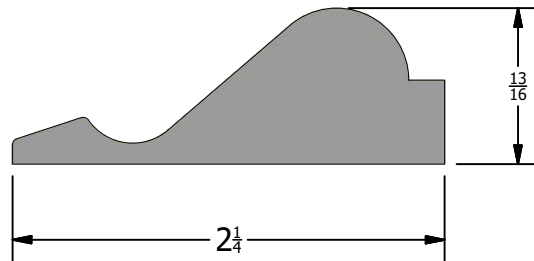

Pan-62

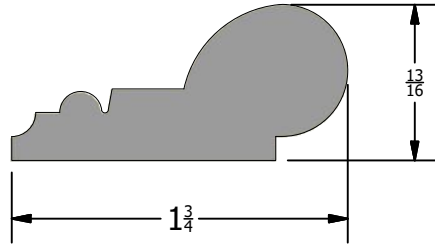

Pan-63

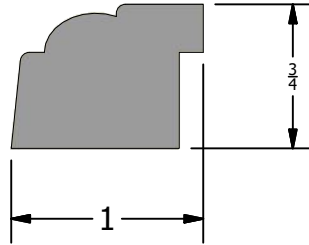

Pan-64

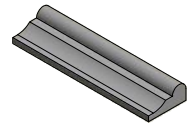
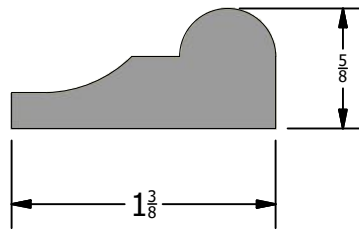

Pan-65-A

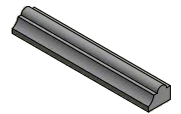
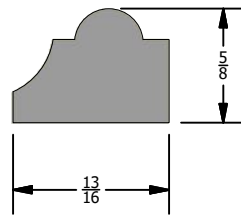

Pan-65-B

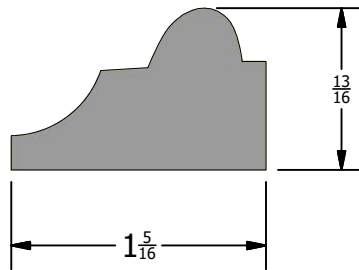

Pan-65-C

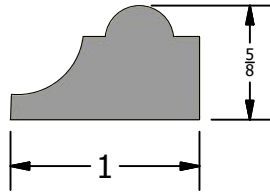

Pan-66-A

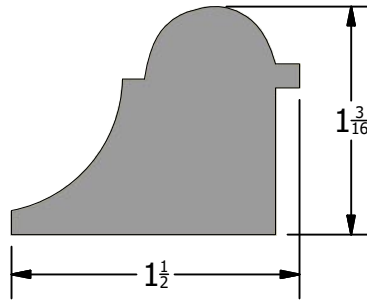

Pan-66-B

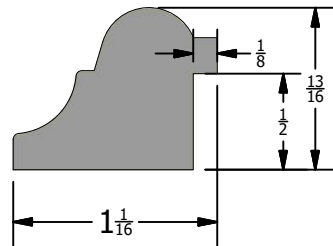

Pan-67

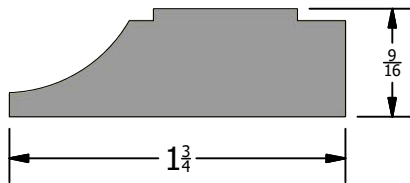

Pan-68

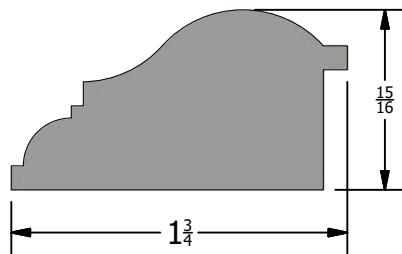

Pan-69

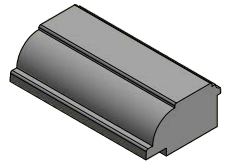
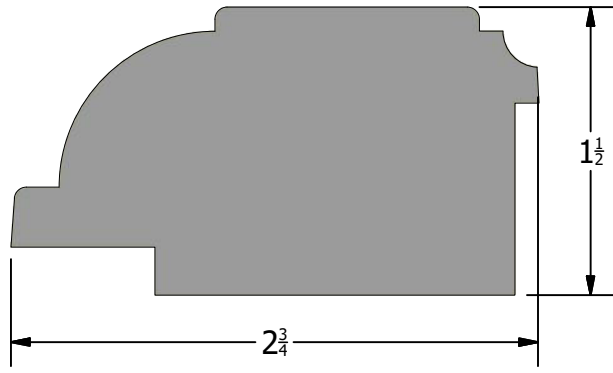

Pan-70

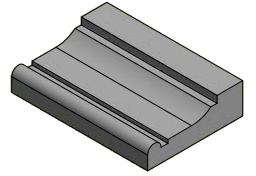
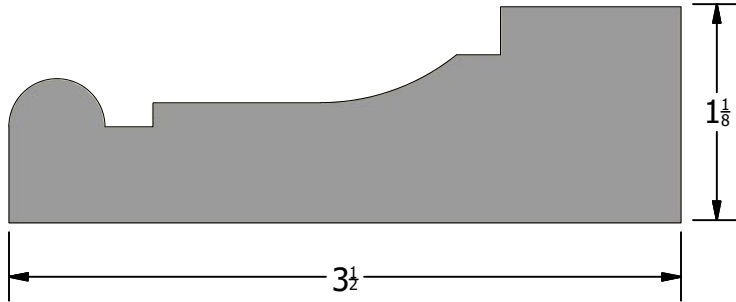

Pan-71

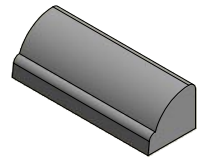
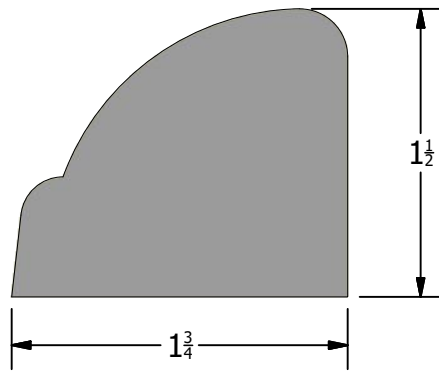

Pan-72

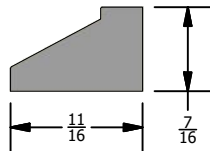

Chair Rails

- Most chair rails can be modified slightly for depth & height.
- Most chair rails can have a rabbet added to receive a panel.

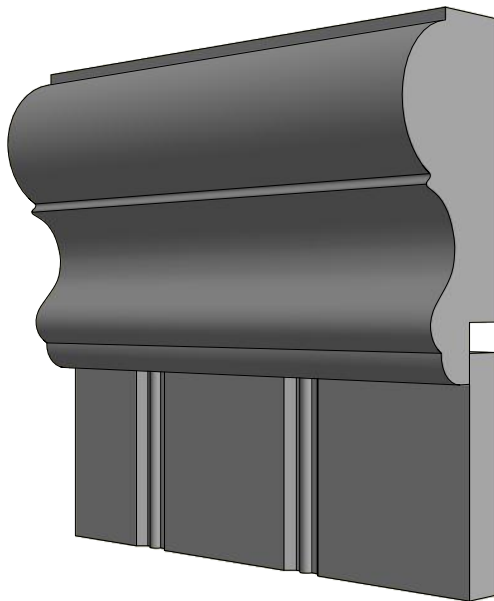

Cha-01

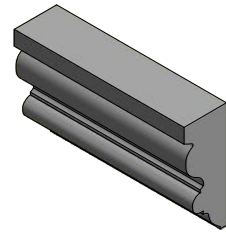
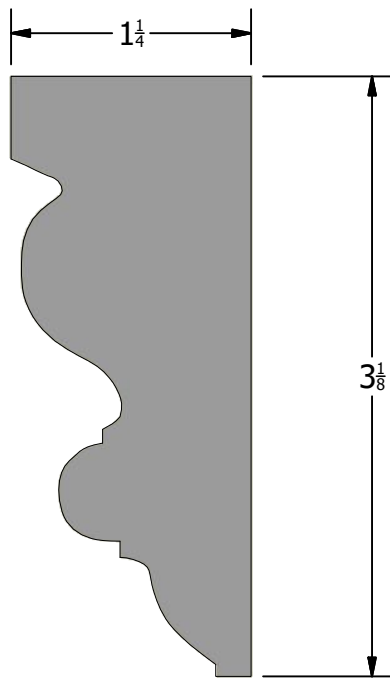

Cha-02

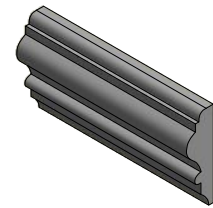
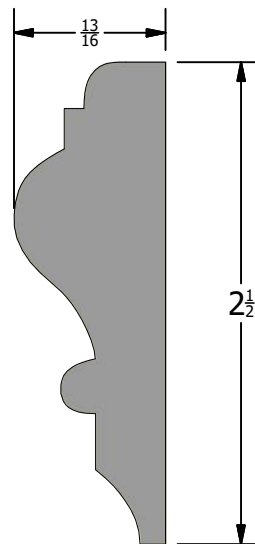

Cha-03

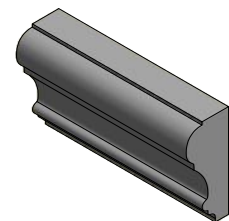
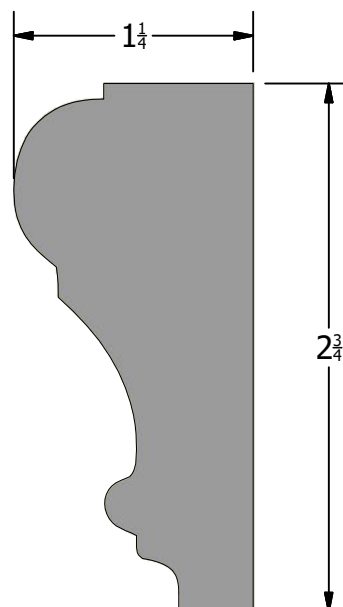

Cha-04

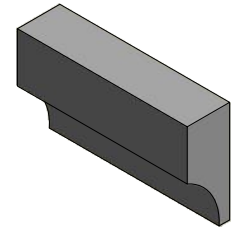
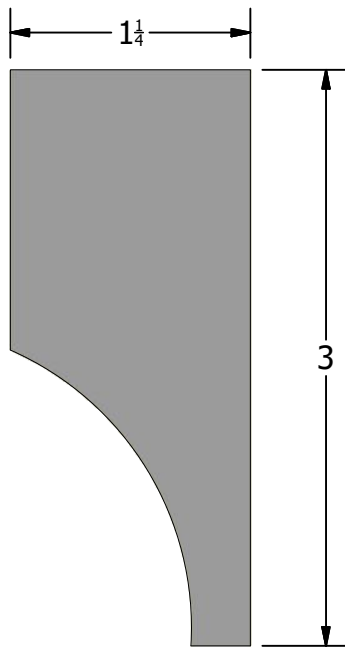

Cha-05

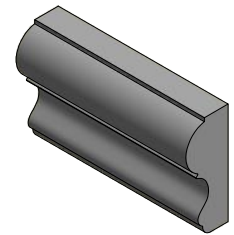
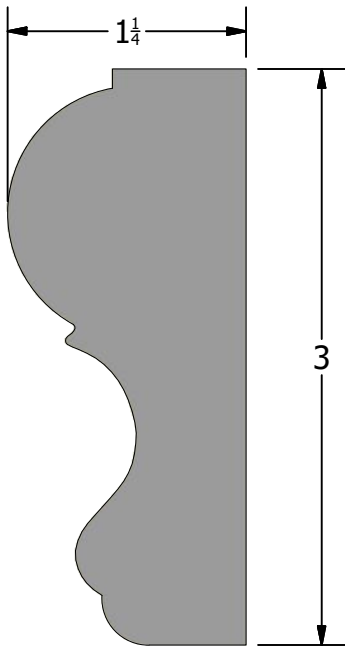

Cha-06

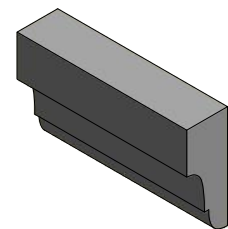
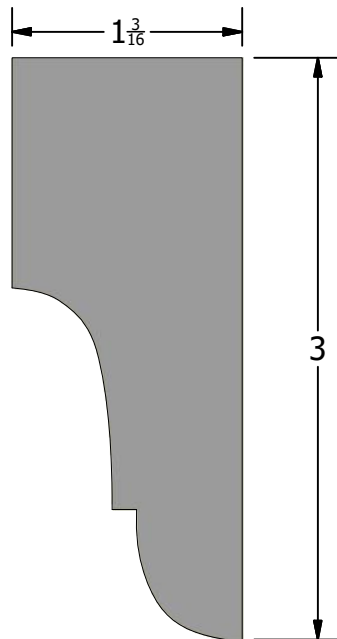

Cha-07

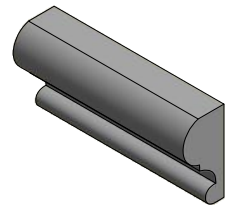
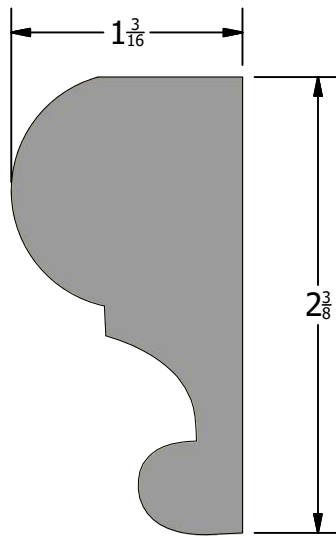

Cha-08

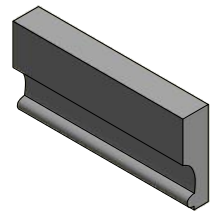
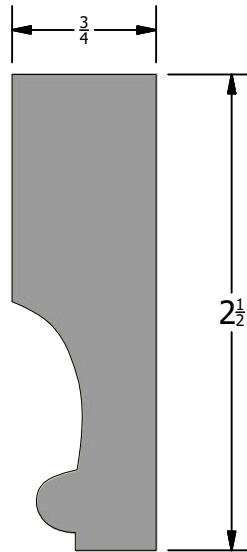

Cha-09-A

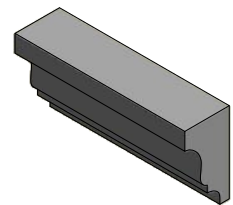
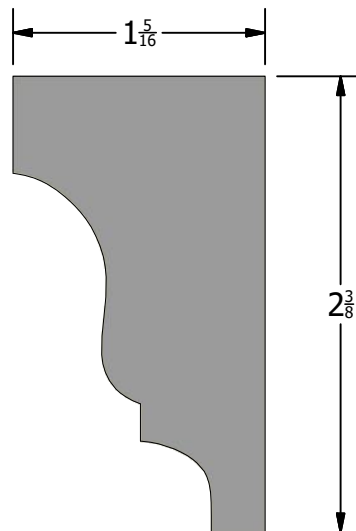

Cha-9-B

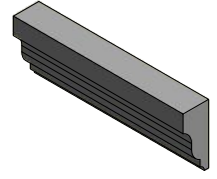
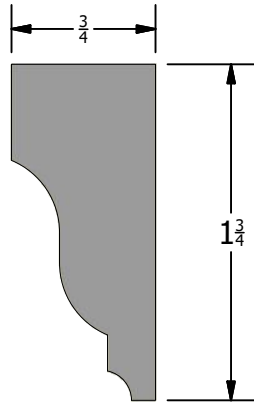

Cha-10

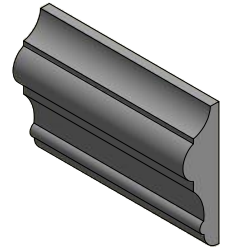
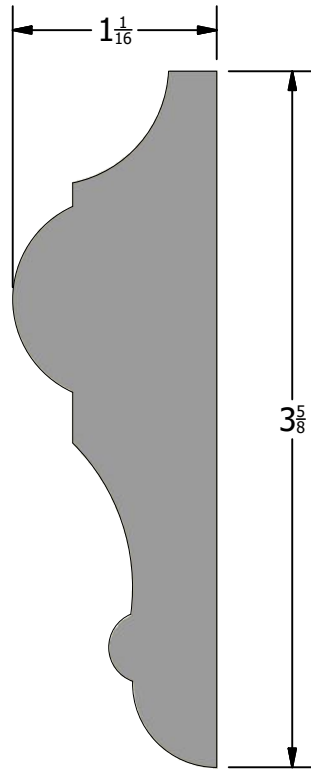

Door Stop

-All DS mouldings can be modified for width.

-DS-E are primarily used on exterior doors and are intended to hold weather strip.

-DS-I are primarily used on interior doors.

-DS-I can be modified to receive a small weather strip for reducing sound transfer and creating a silent close option.

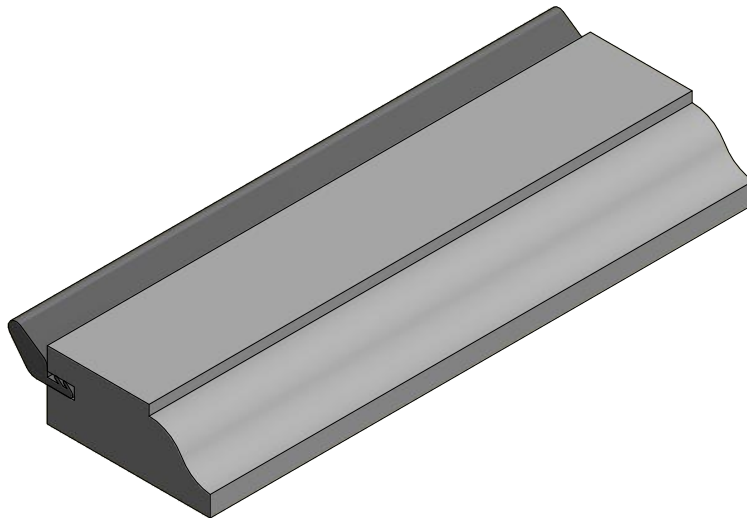

DS-E-01

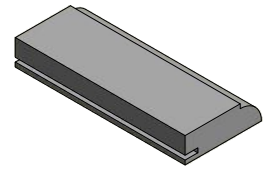
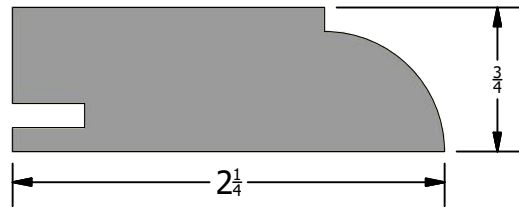

DS-E-02

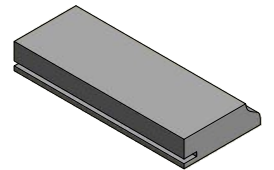
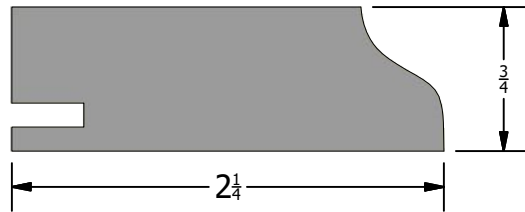

DS-E-03

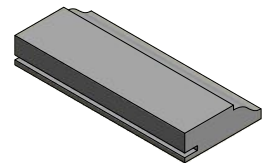
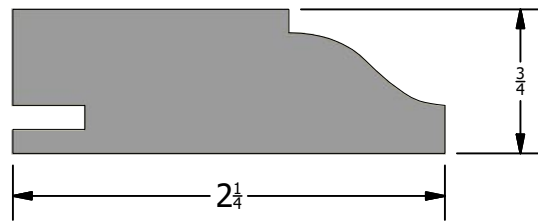

DS-E-04

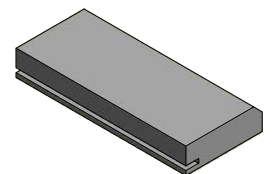
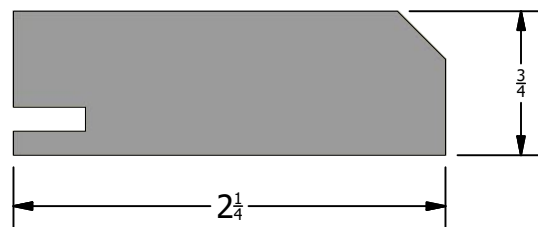

DS-E-05

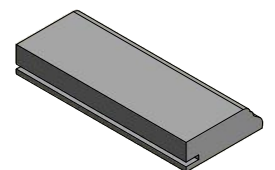
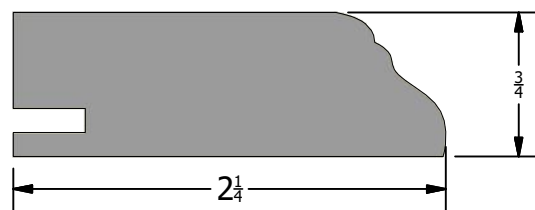

DS-I-01

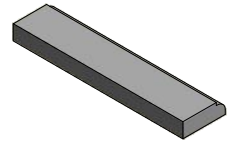
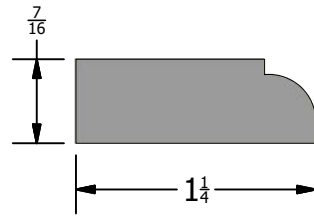

DS-I-02

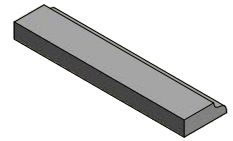
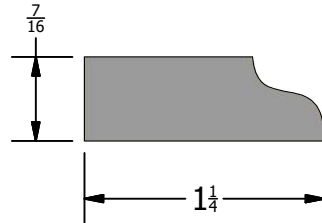

DS-I-03

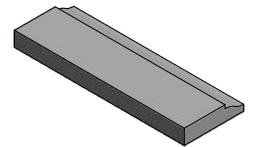
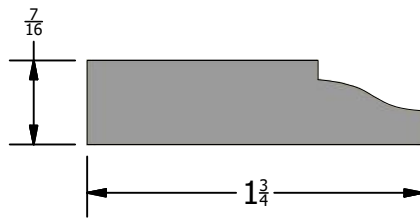

DS-I-04

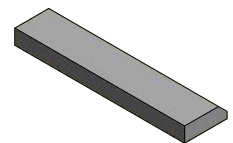
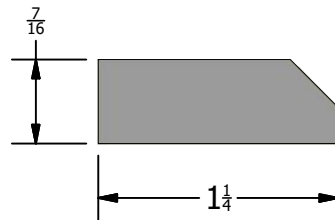

DS-I-05

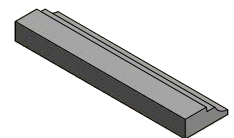
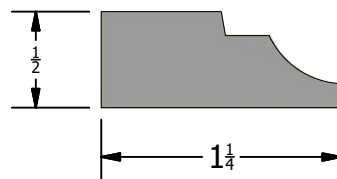

DS-I-06

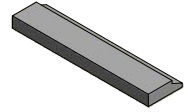
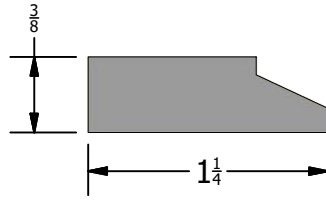

DS-I-07

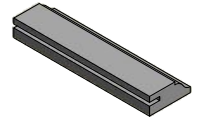
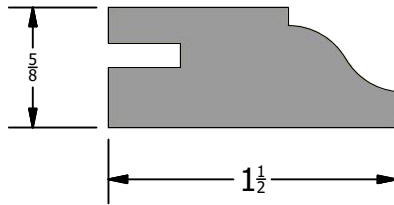

Window Sills

-Most Sill moulds can be modified for height & width.



Sill-01

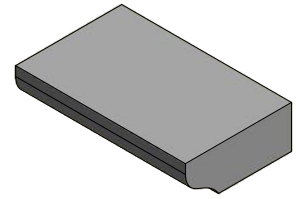
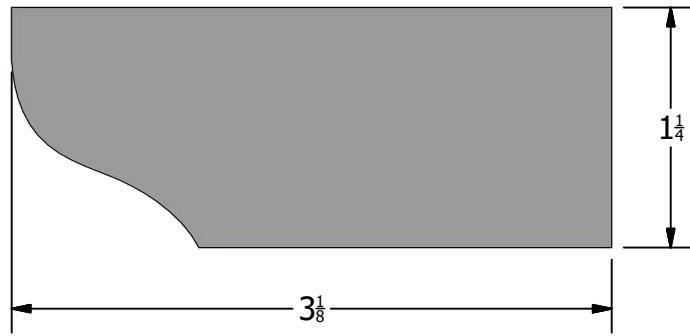

Sill-02

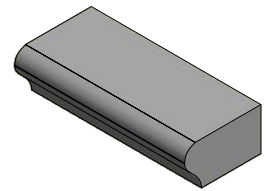
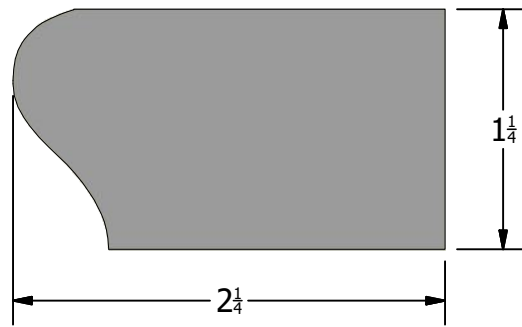

Sill-03

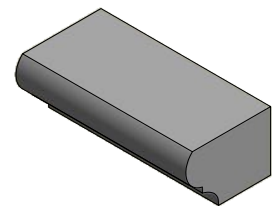
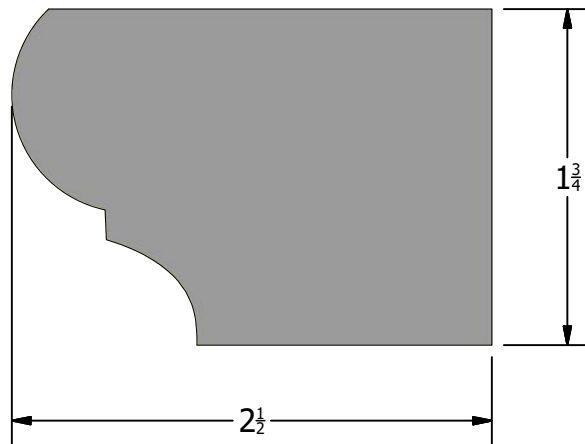

Sill-04

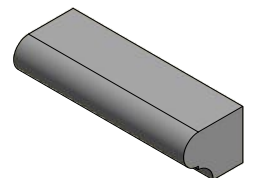
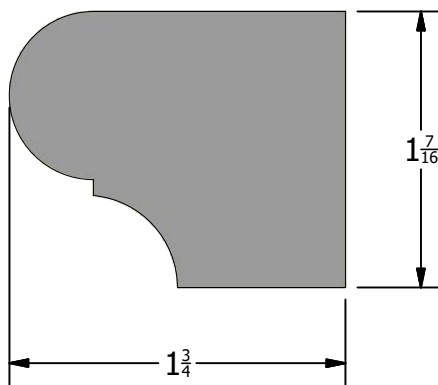

Sill-05

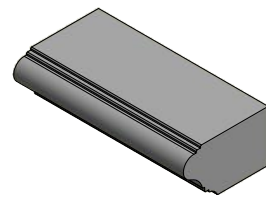
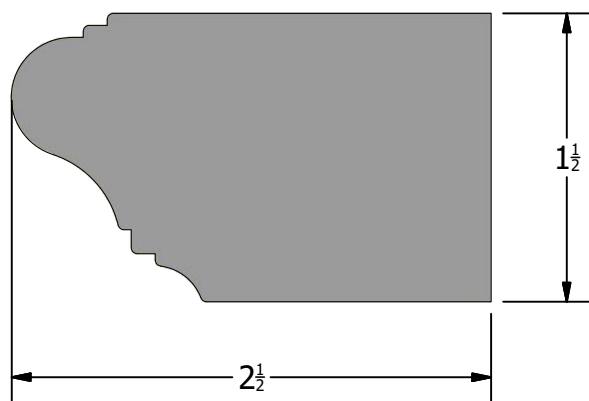

Sill-06

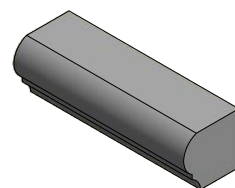
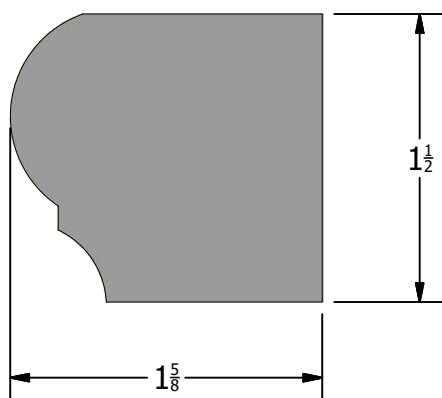

T & G Panels

-All T & G can be modified for widths up to a maximum of 9 1/4" over all.

-Thickness can be modified somewhat.

-Size of chamfer can be modified from a micro bevel up to 1/4".

-T & G-05 is a reverse nail flange and can be done without the bead.

-TG-09 is our standard flooring cutter.

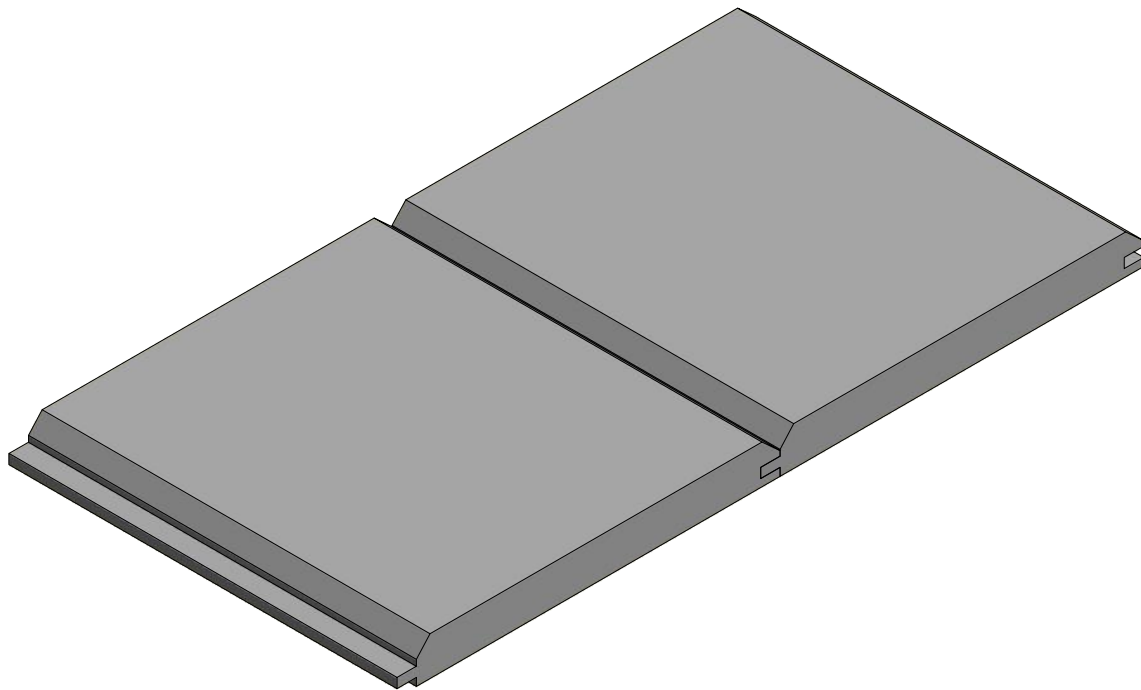

TG-01

Scale
1 / 2

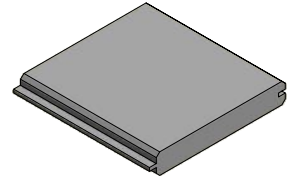
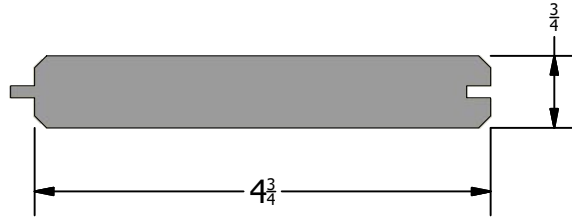

TG-02

Scale
1 / 2

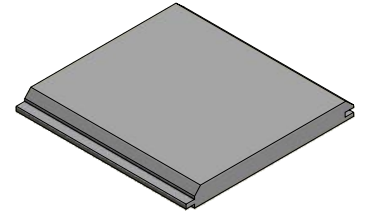
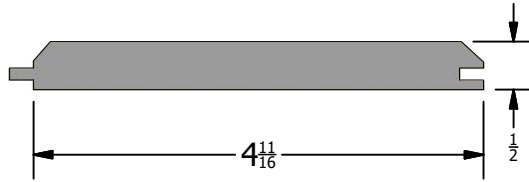

TG-03

Scale
1 / 2

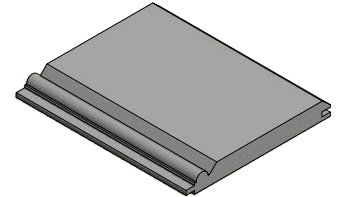
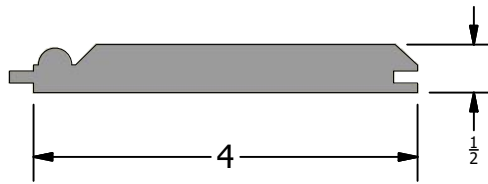

TG-04

Scale
1 / 2

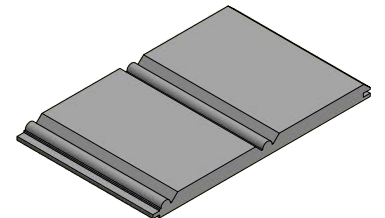
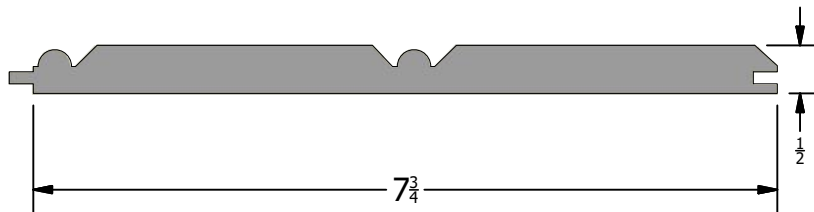

TG-05

Scale
1 / 2

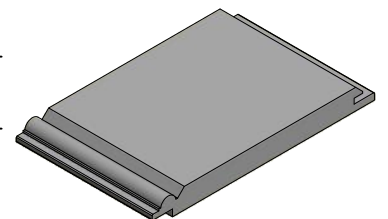
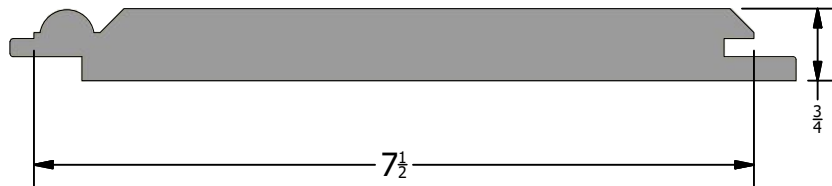

TG-06

Scale
1 / 2

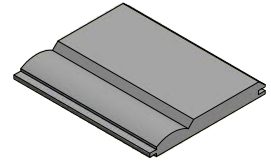
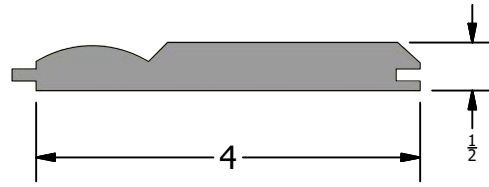

TG-07

Scale
1 / 2

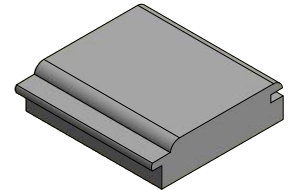
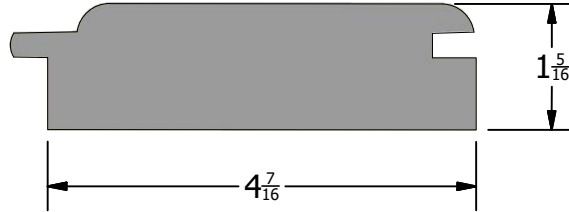

TG-08

Scale
1 / 2

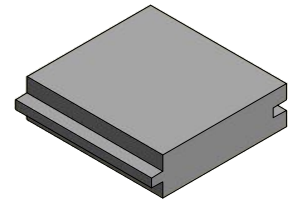
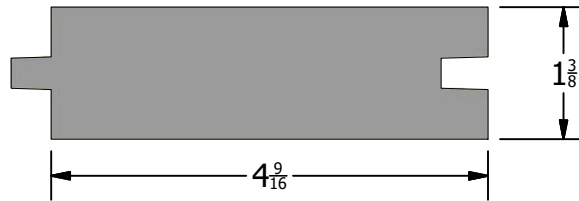

TG-09-A

Scale
1 / 2

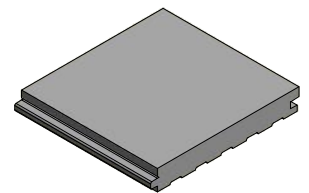
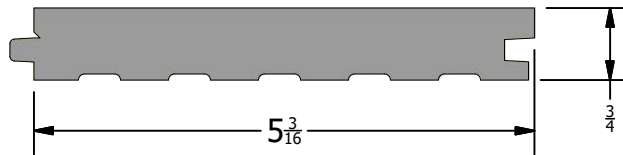

TG-09-B

Scale
1 / 2

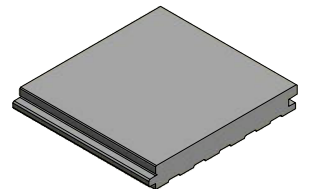
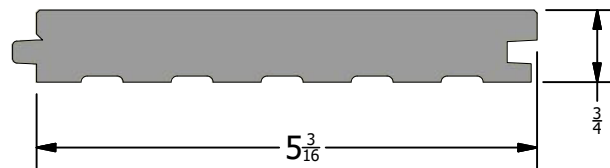

TG-09-C

Scale
1/2

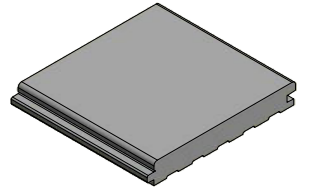
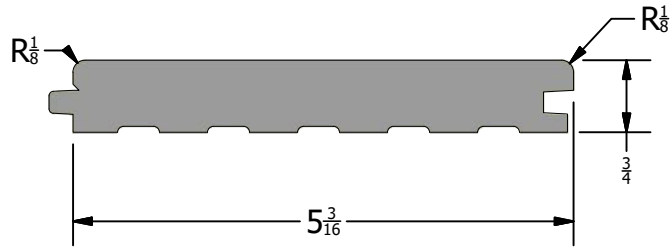

TG-10

Scale
1/2

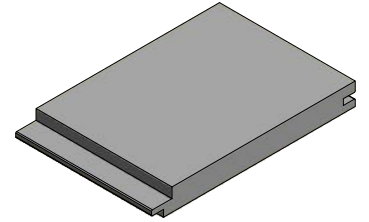
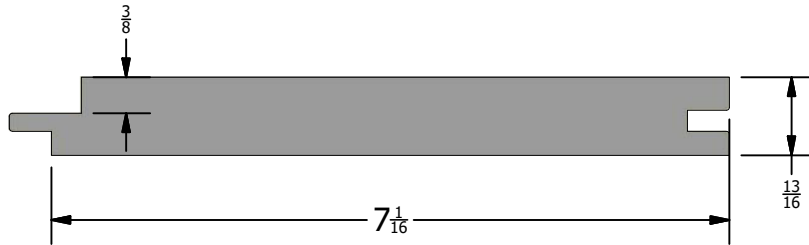

Shiplap

-SHL-01, 02 & 03 can be modified for width.

-SHL-01 can be modified for size of chamfer from micro bevel up to 1/4".

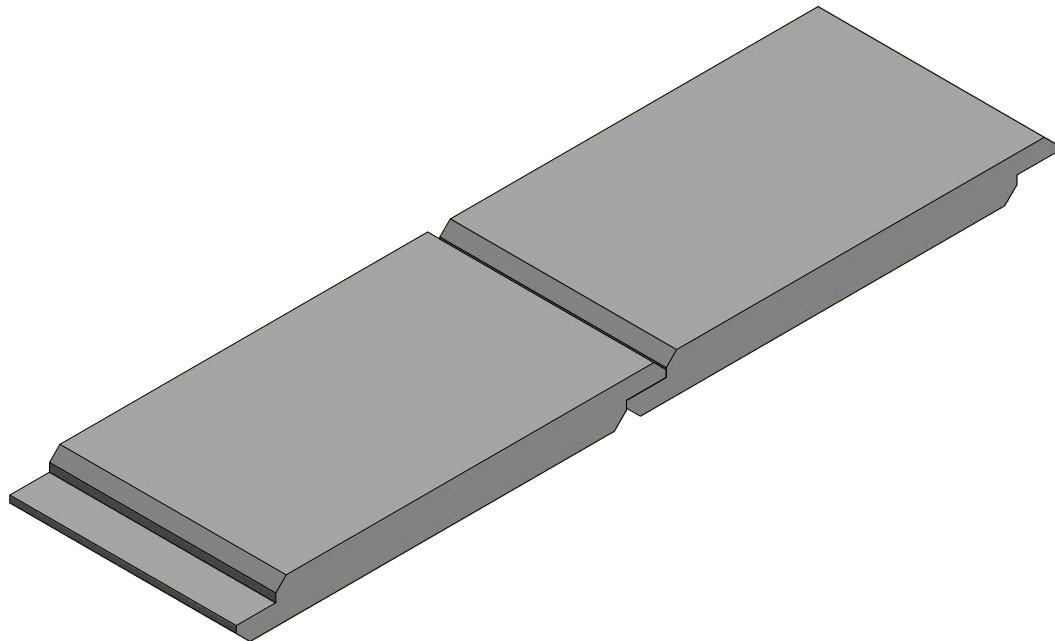

SHL-01

Scale
1 / 2

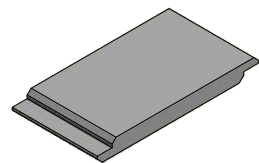
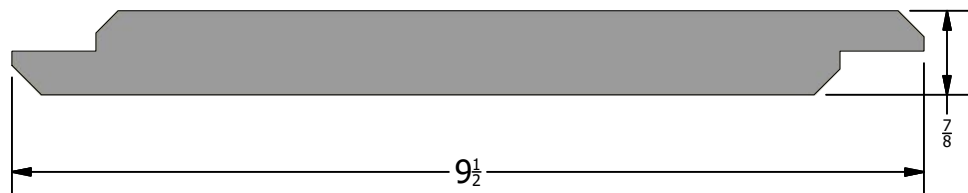

SHL-02

Scale
1 / 2

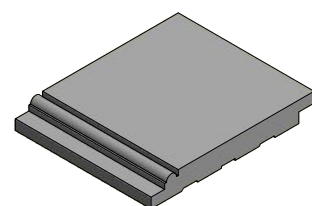
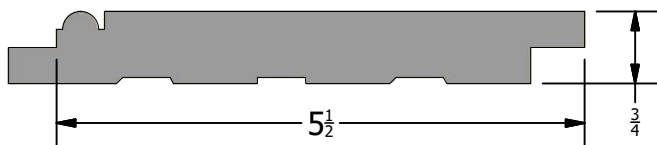

SHL-03

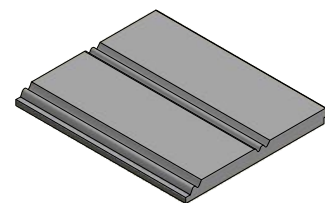
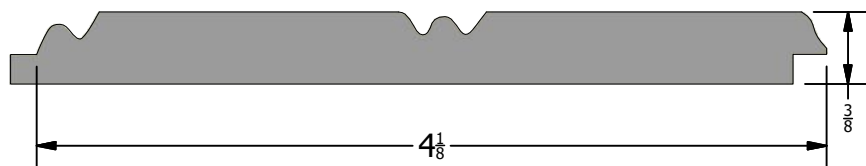

SHL-04

Scale
1 / 2

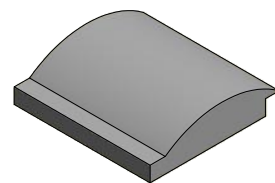
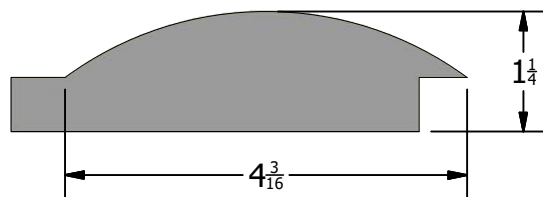

SHL-05

Scale
1 / 2

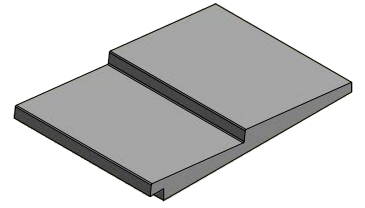
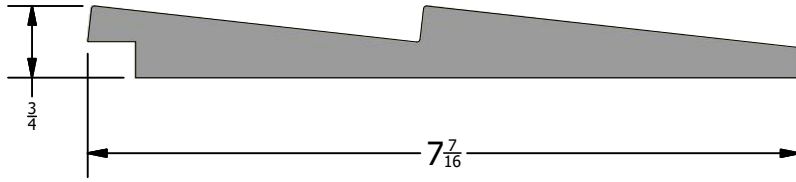

Handrails

- Check with a salesman for possible modifications.
- Check with salesman for easement options.

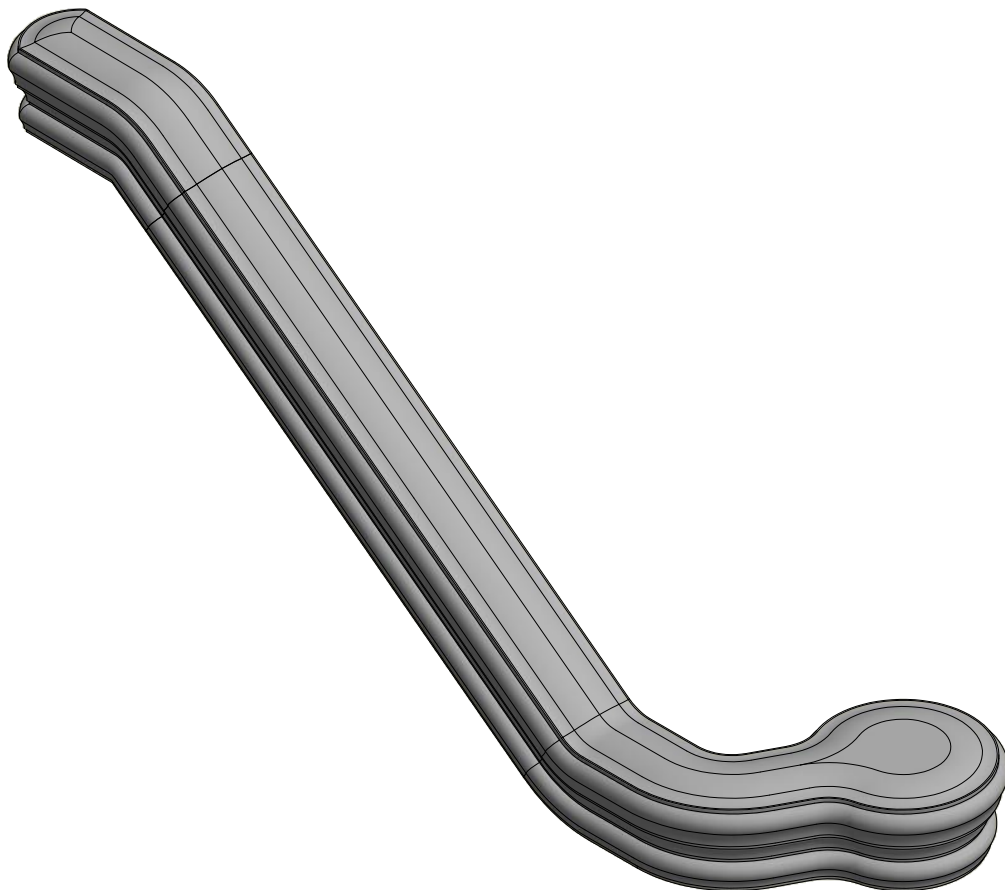

HR-01

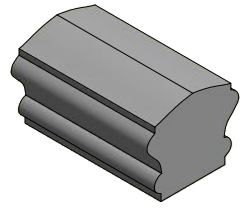
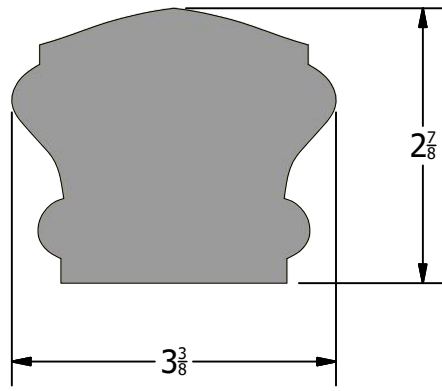

HR-02

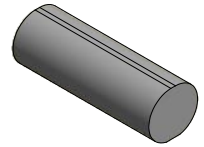
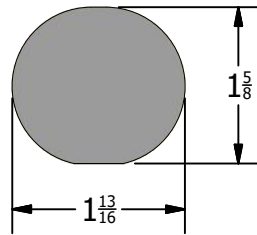

HR-03

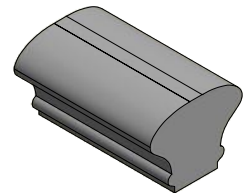
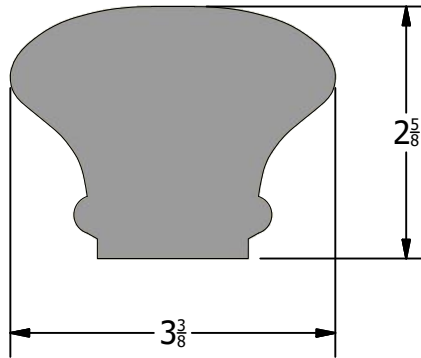

HR-04

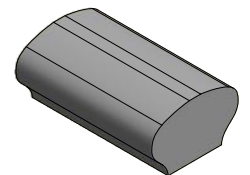
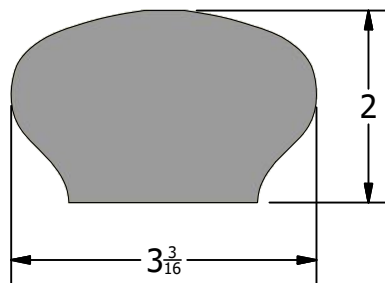

HR-05

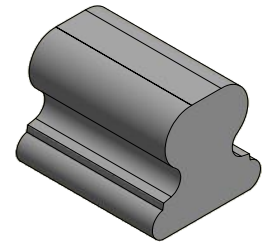
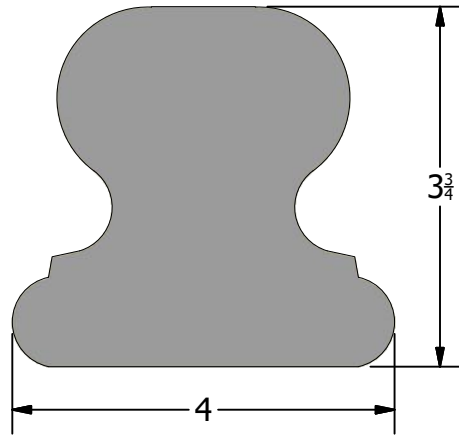

HR-06

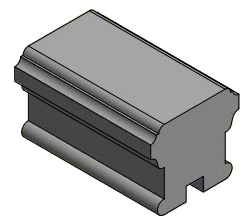
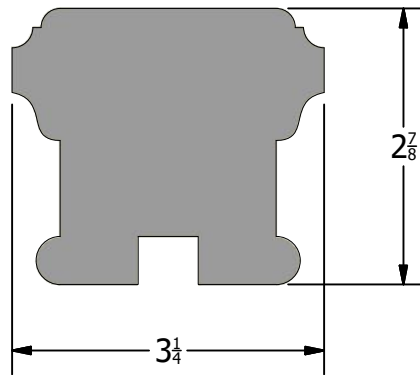

HR-07

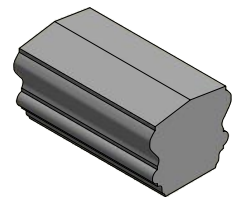
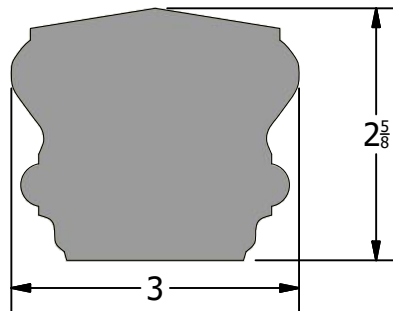

HR-08

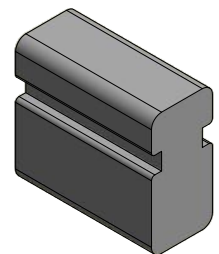
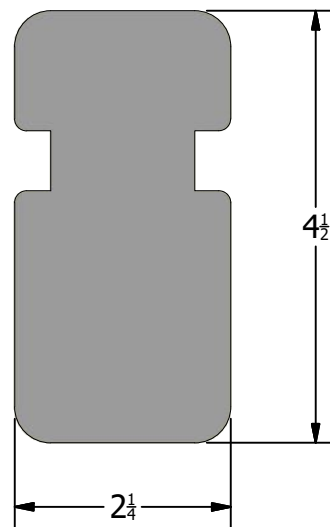

HR-09

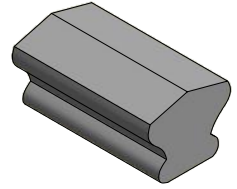
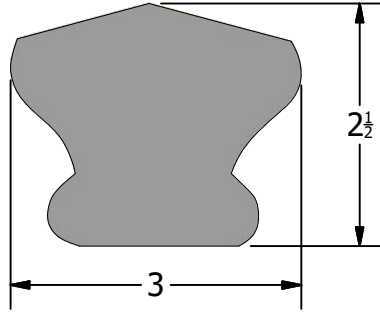

HR-10

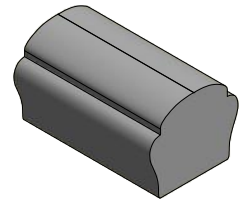
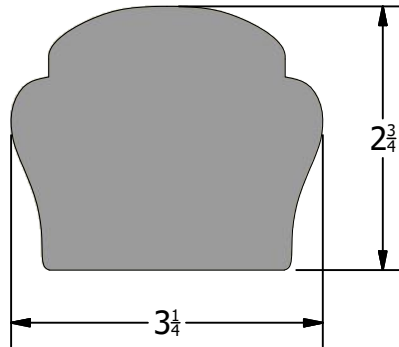

HR-11

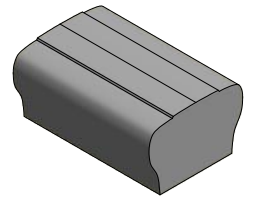
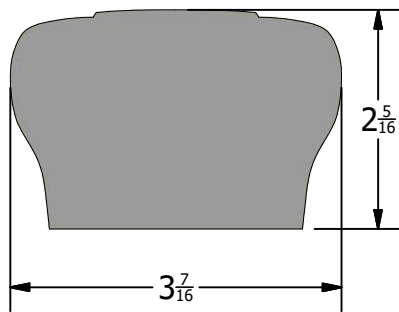

HR-12-A

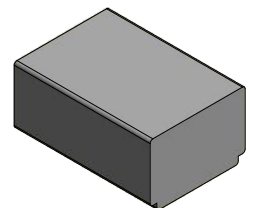
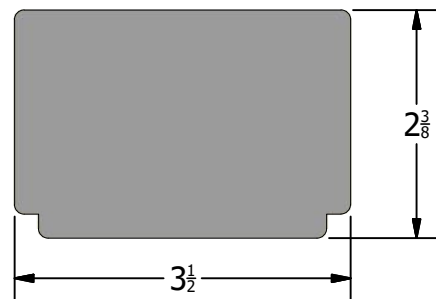

HR-12-B

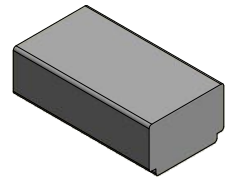
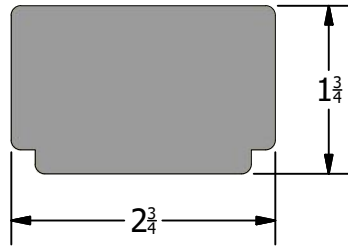

HR-13

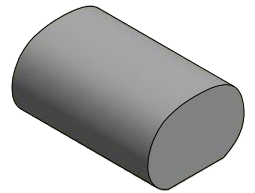
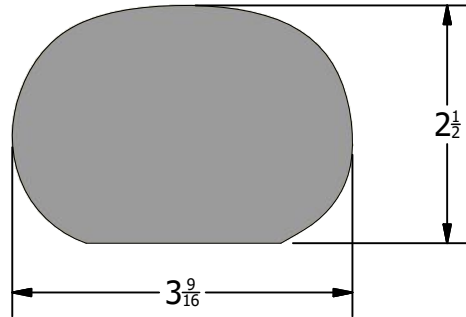

HR-14

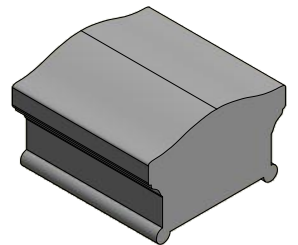
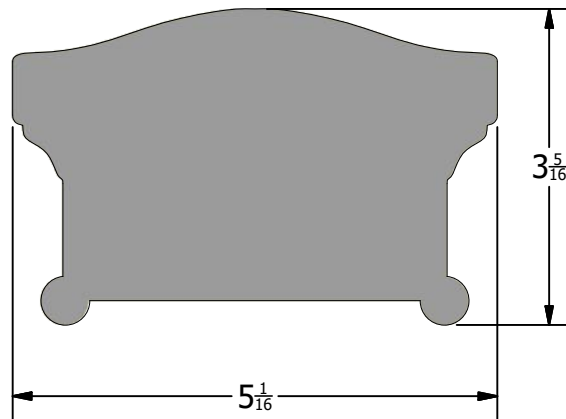

HR-15

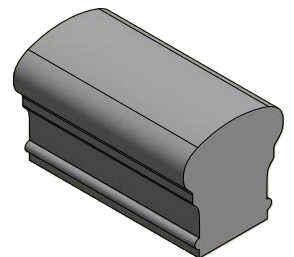
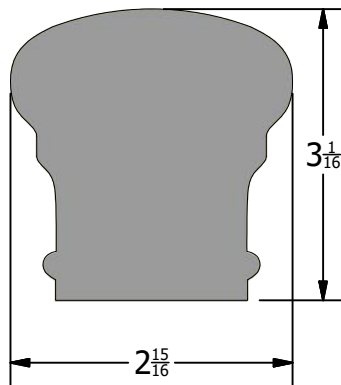

HR-17

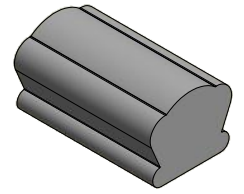
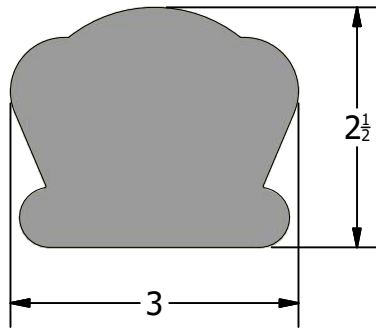

HR-18

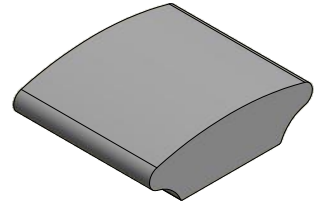
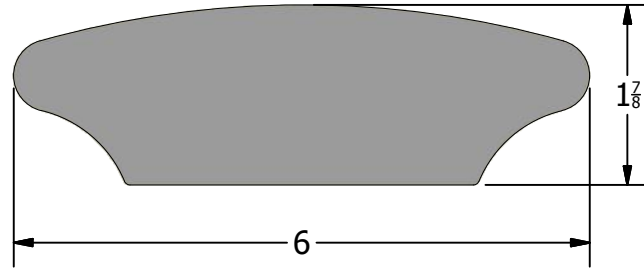

HR-19

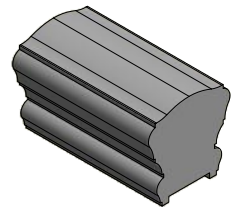
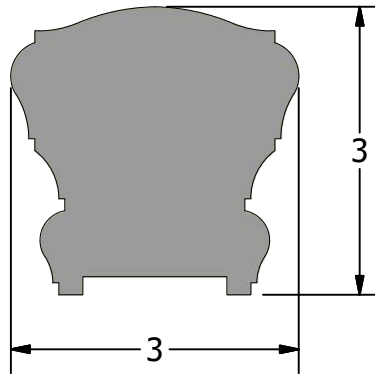



Plinth Blocks

- Some Plinth blocks can be modified for width.
- Our standard height for plinth blocks is base plus 1/2"
- Keep in mind, when using plinth blocks, the bottom hinge on your door must be set above the plinth block.

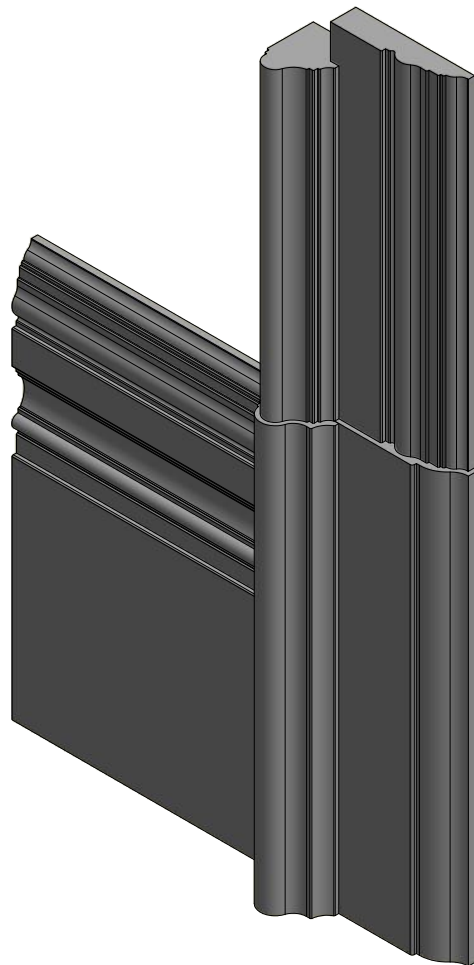

Plinth-01
Scale
1 / 2

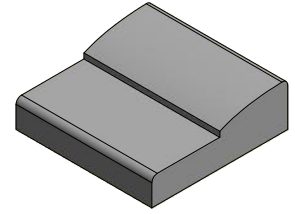
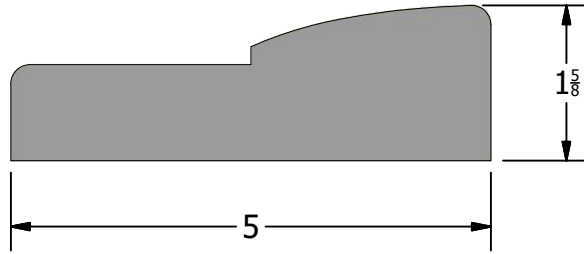

Plinth-02
Scale
1 / 2

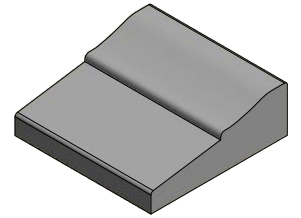
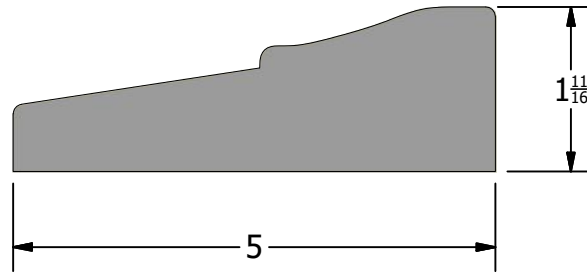

Plinth-03
Scale
1 / 2

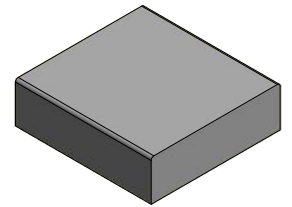
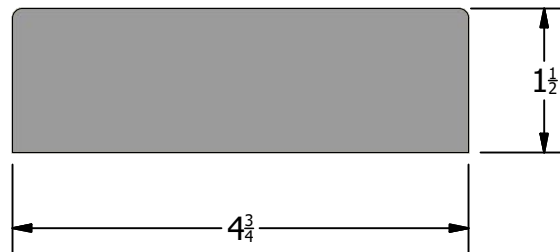

Plinth-04
Scale
1 / 2

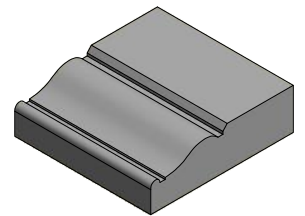
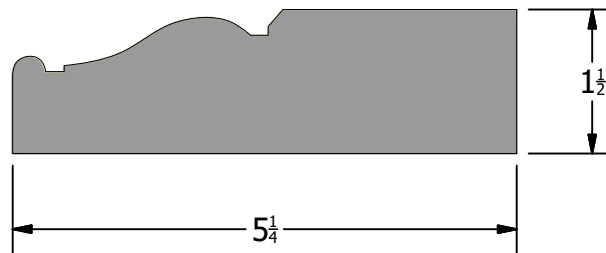

Plinth-05
Scale
1 / 2

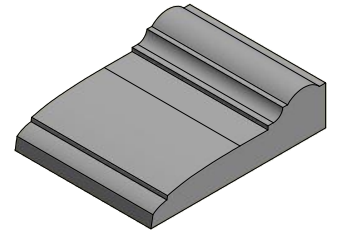
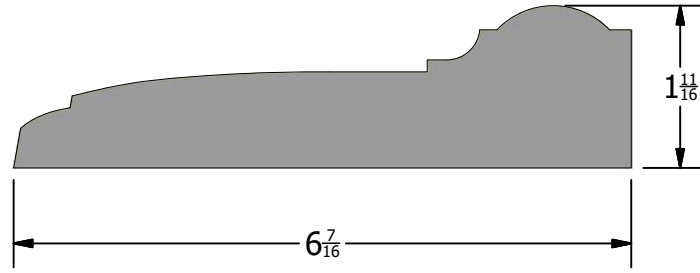

Plinth-06
Scale
1 / 2

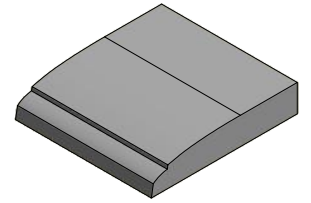
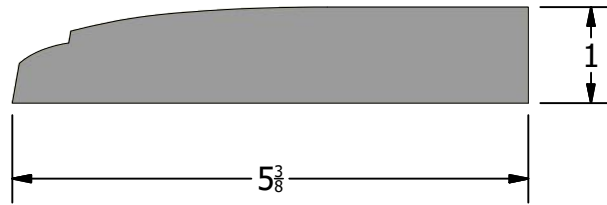

Plinth-07
Scale
1 / 2

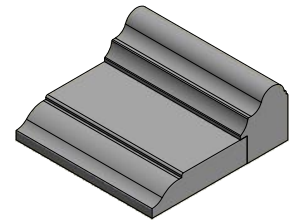
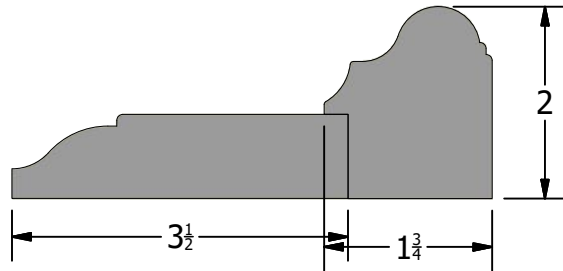

Plinth-08
Scale
1 / 2

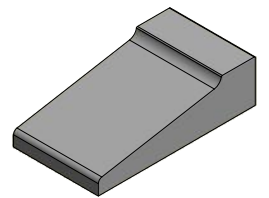
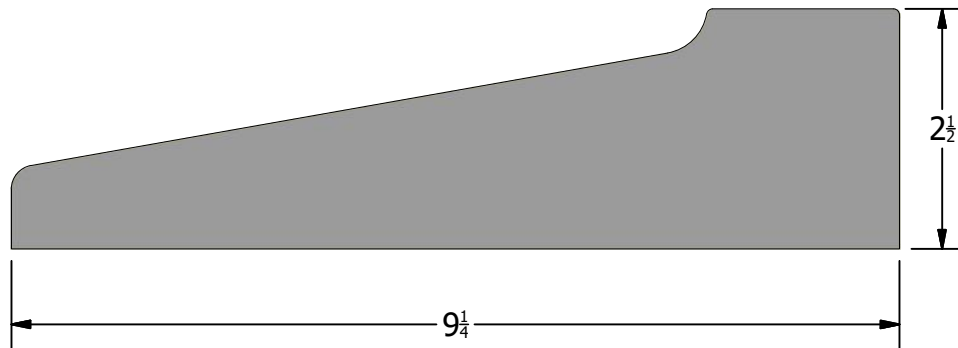

Plinth-09
Scale
1 / 2

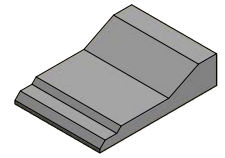
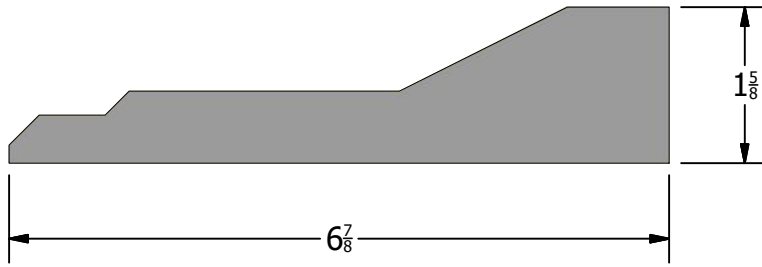

Plinth-10
Scale
1 / 2

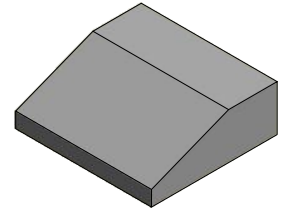
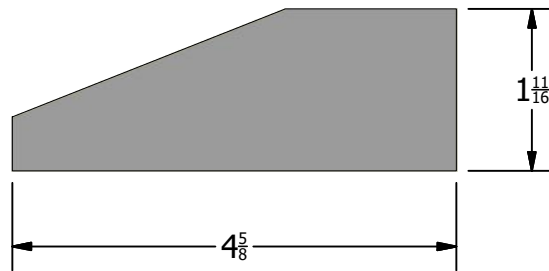

Brick Mould

- Some modifications can be made.
- Used primarily on exterior doors and windows.

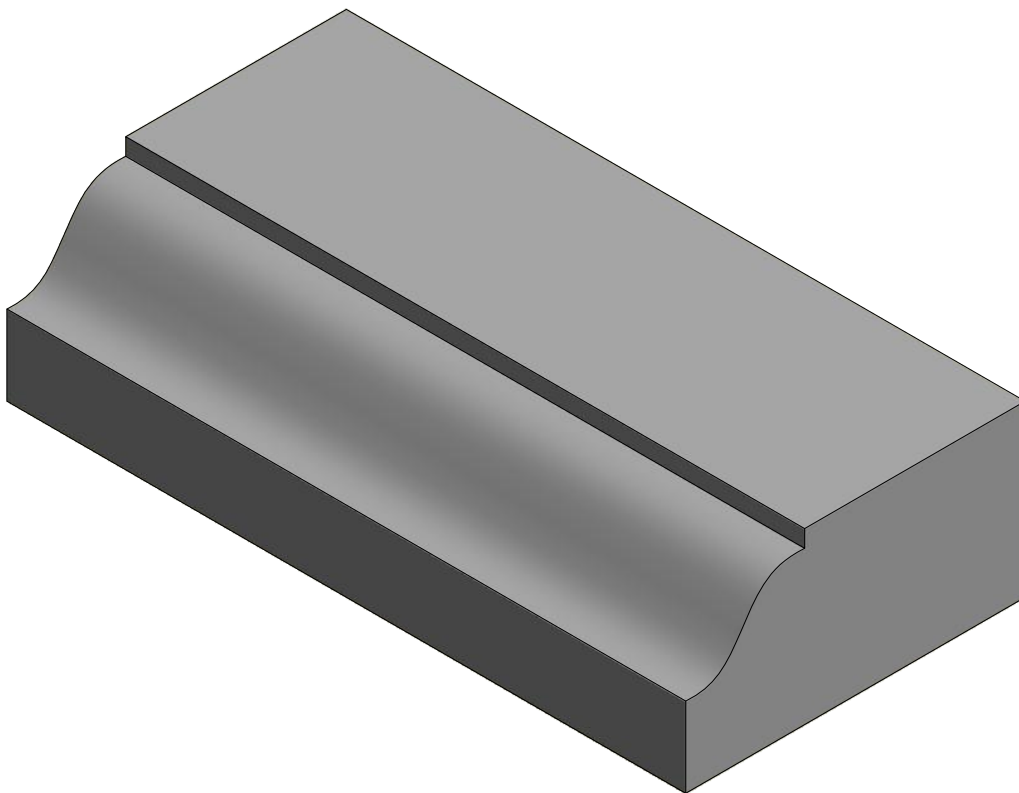

BM-01

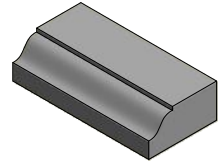
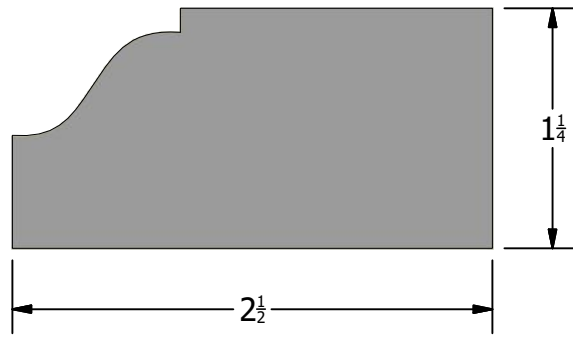

BM-02

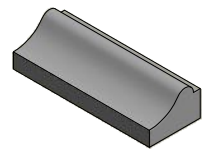
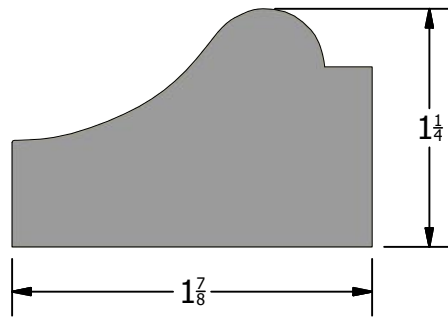

BM-03

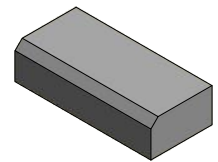

BM-04

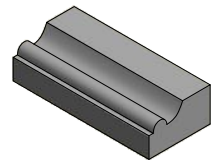
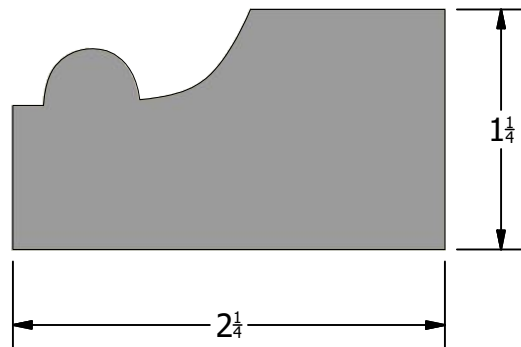

BM-05

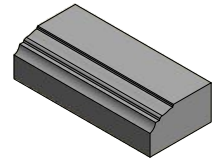
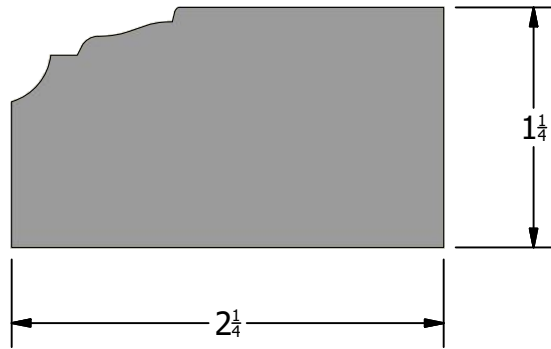

BM-06

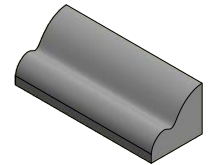
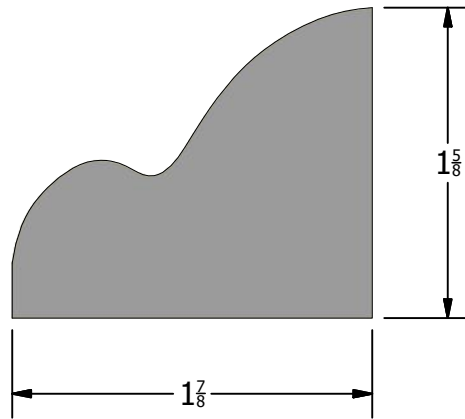

BM-07

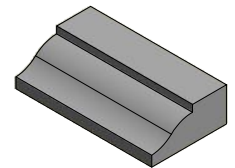
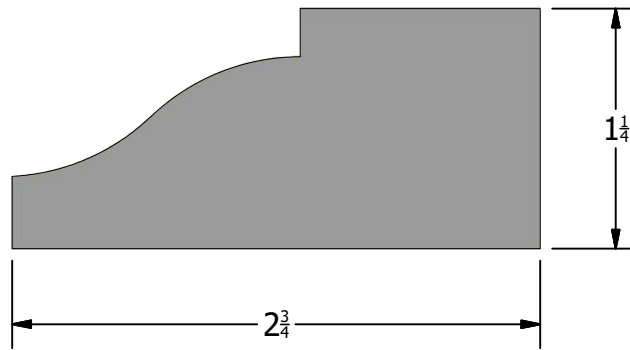

BM-08

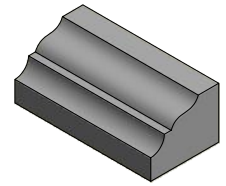
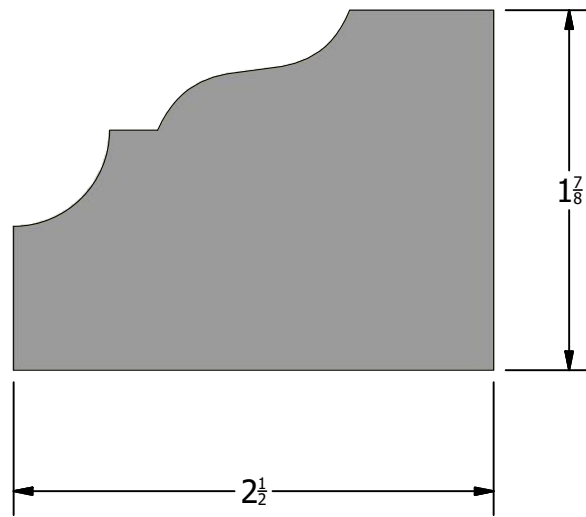

BM-09

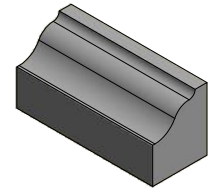
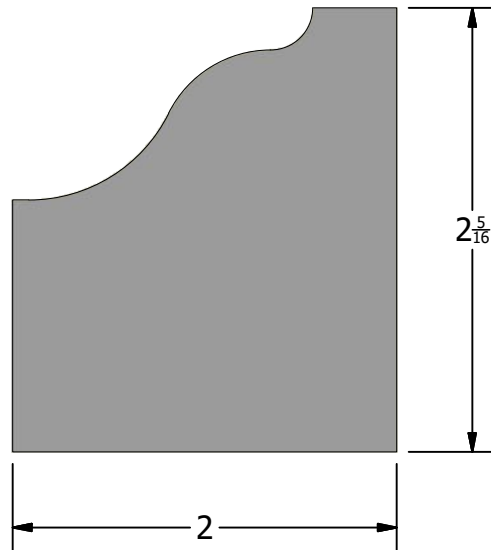

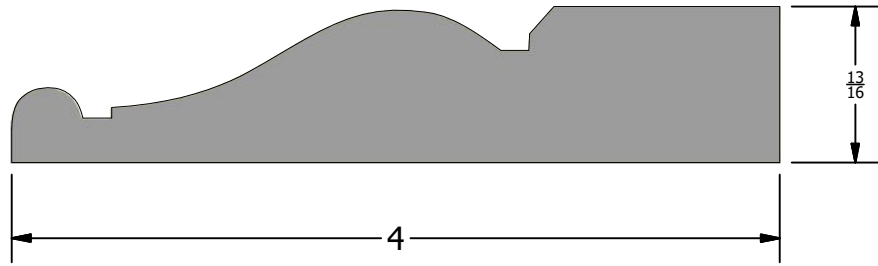

Description
Casing Base Board

Part Number
CB-01

-122-

Back

Scale 1 : 1



HOMESTEAD
WOODWORKS

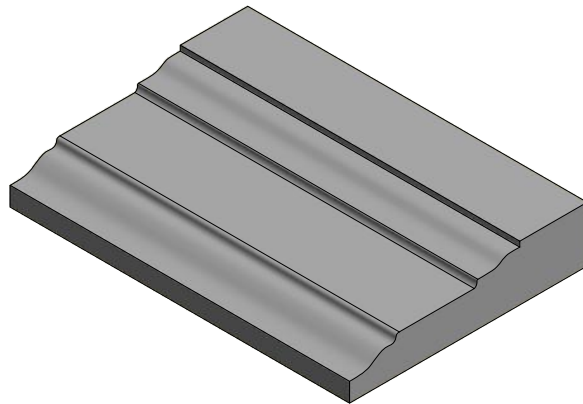
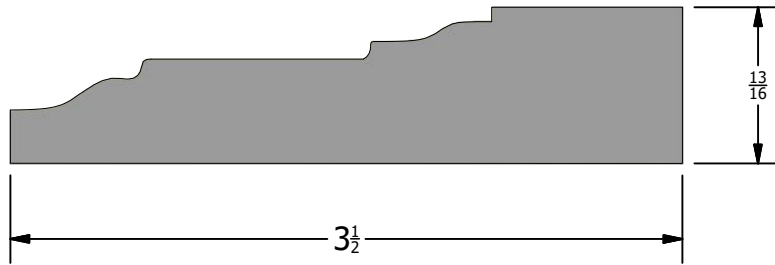

Description
Casing Base Board

Part Number
CB-02

-123-

Back

Scale 1 : 1



HOMESTEAD
WOODWORKS

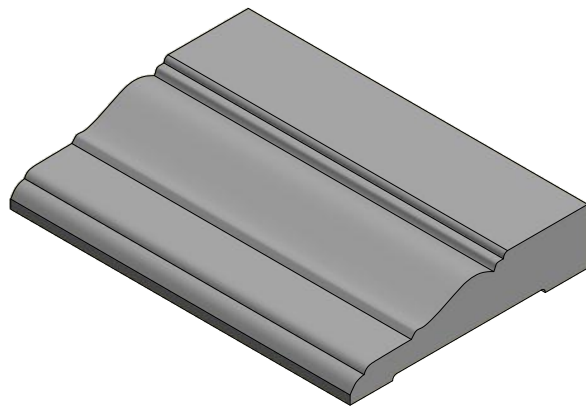
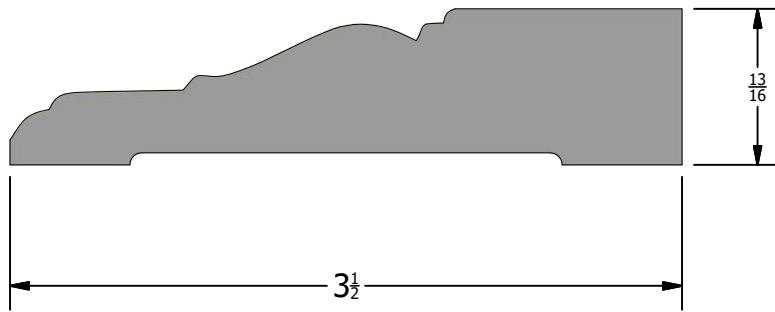

Description
Casing Base Board

Part Number
CB-03

-124-

Back

Scale 1 : 1



HOMESTEAD
WOODWORKS

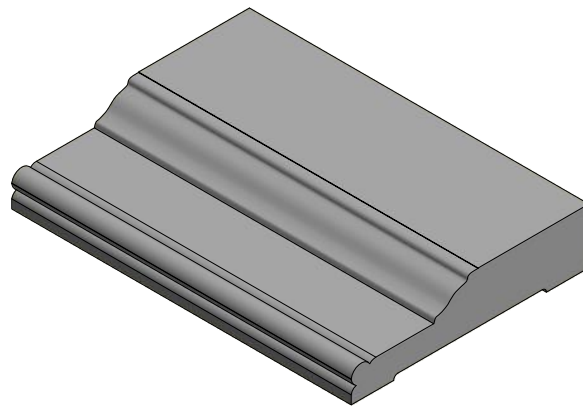
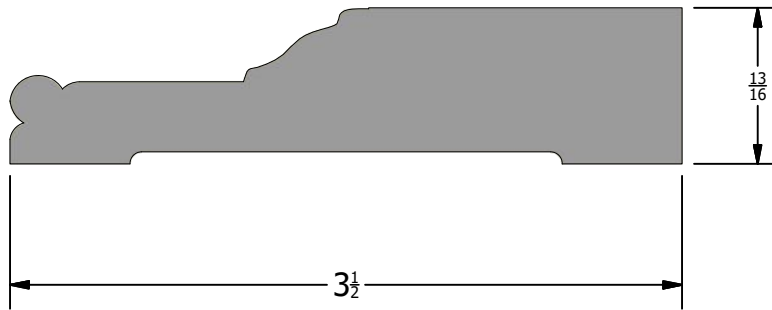

Description
Casing Base Board

Part Number
CB-04

-125-

Back

Scale 1 : 1



HOMESTEAD
WOODWORKS

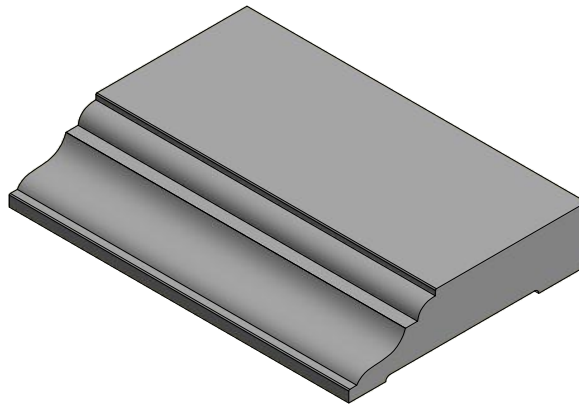
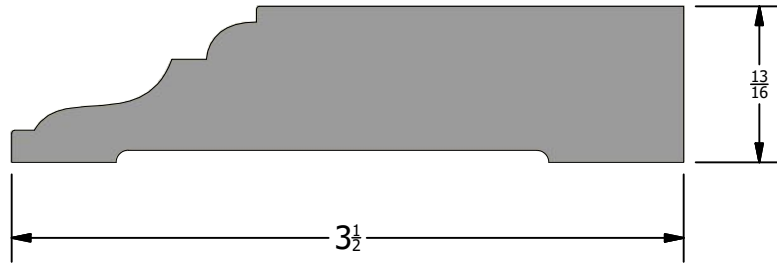

Description
Casing Base Board

Part Number
CB-05

-126-

Back

Scale 1 : 1



HOMESTEAD
WOODWORKS

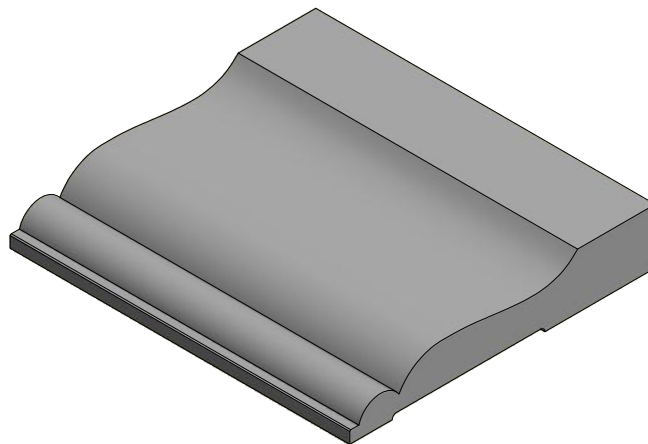
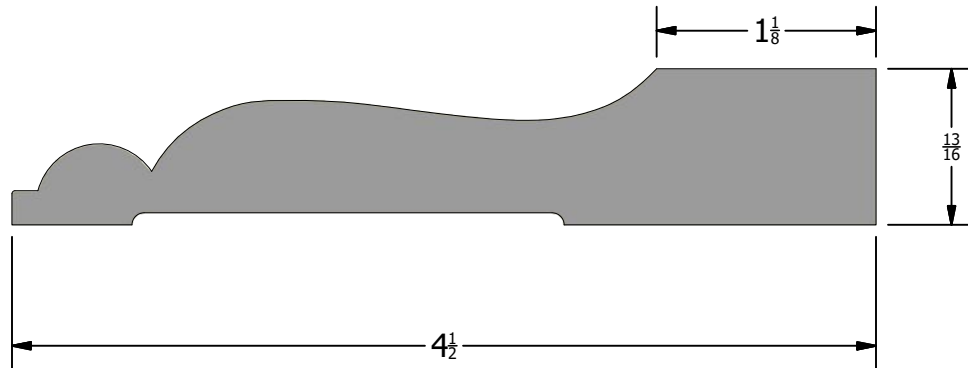

Description
Casing Base Board

Part Number
CB-06 -A

-127-

Back

Scale 1 : 1



HOMESTEAD
WOODWORKS

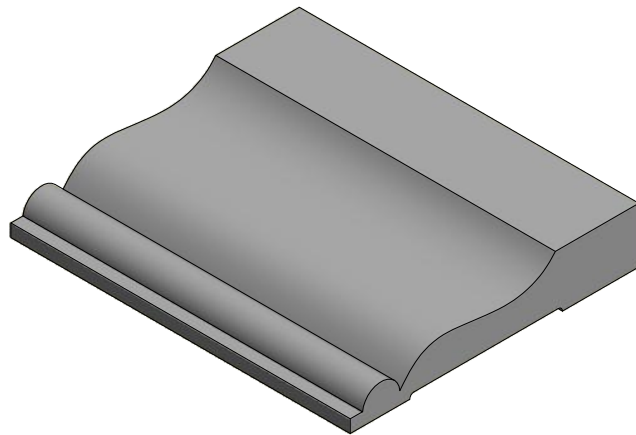
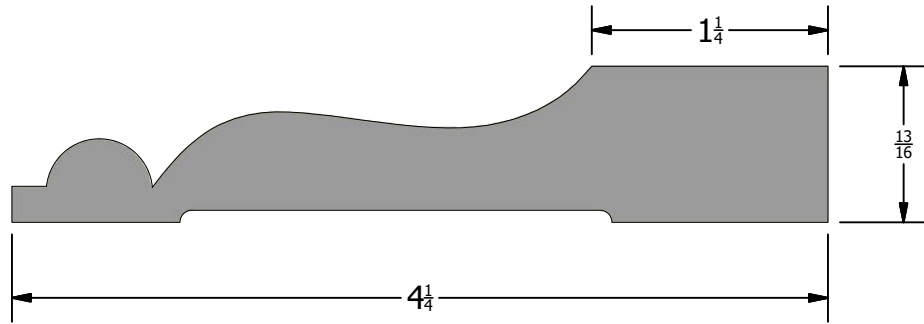

Description
Casing Base Board

Part Number
CB-06-B

-128-

Back

Scale 1 : 1



HOMESTEAD
WOODWORKS

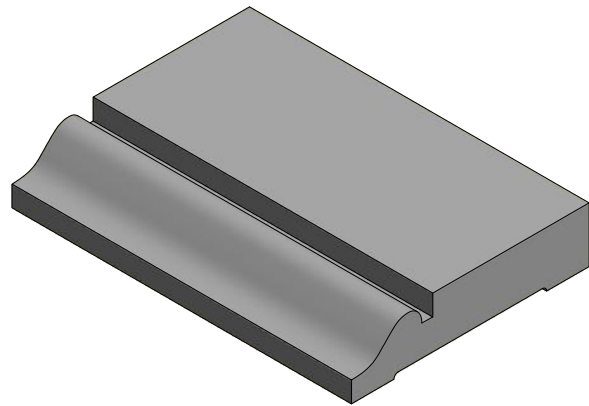
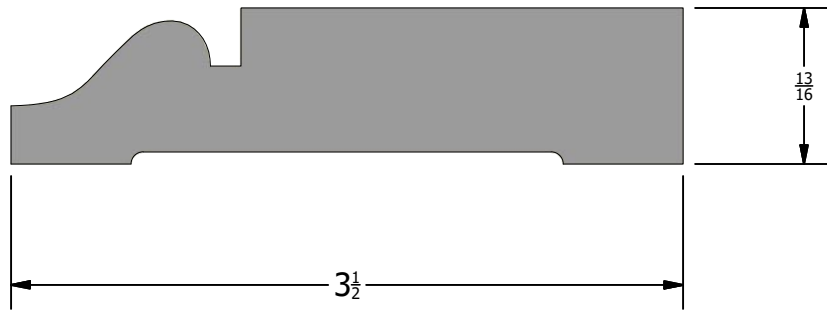

Description Casing Base Board		Part Number CB-07	 HOMESTEAD WOODWORKS
-129-	Back	Scale 1 : 1	

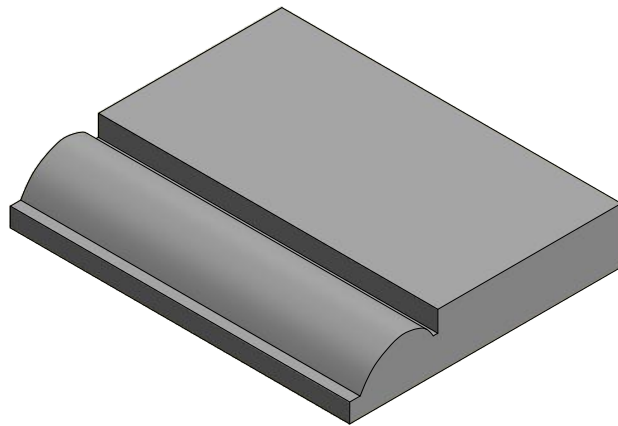
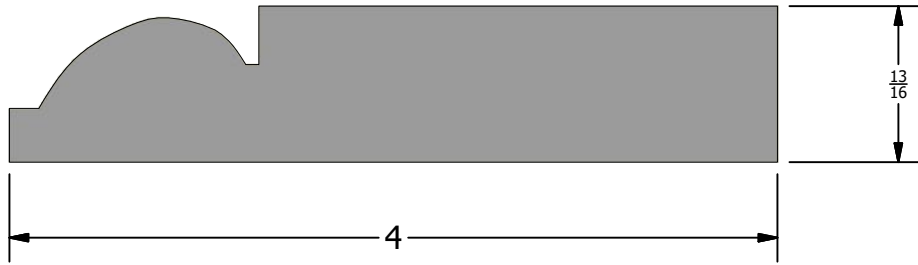

Description
Casing Base Board

Part Number
CB-08

-130-

Back

Scale 1 : 1



HOMESTEAD
WOODWORKS

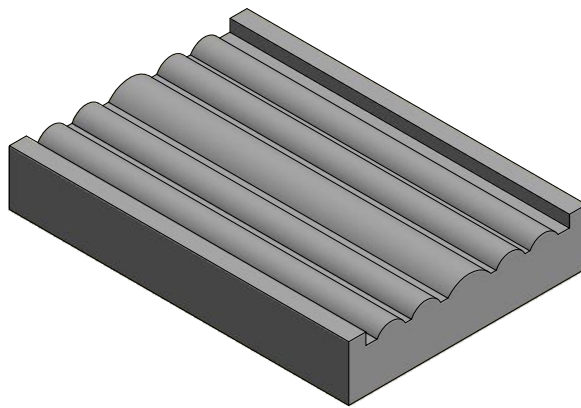
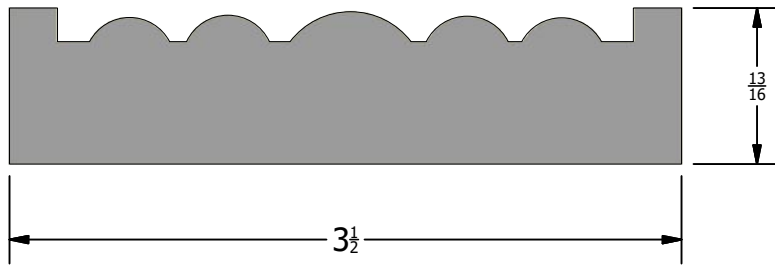

Description
Casing Base Board

Part Number
CB-09

-131-

Back

Scale 1 : 1



HOMESTEAD
WOODWORKS

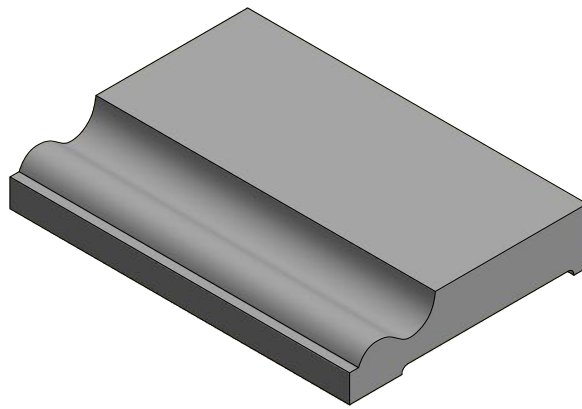
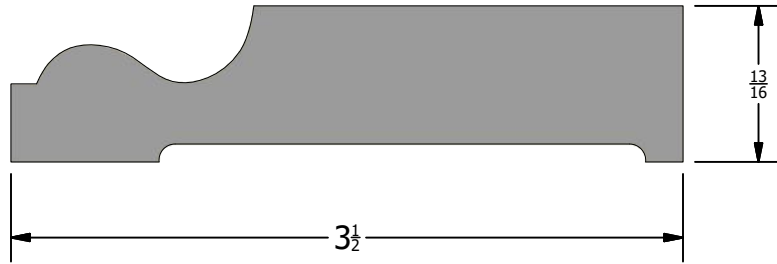

Description
Casing Base Board

Part Number
CB-10

-132-

Back

Scale 1 : 1



HOMESTEAD
WOODWORKS

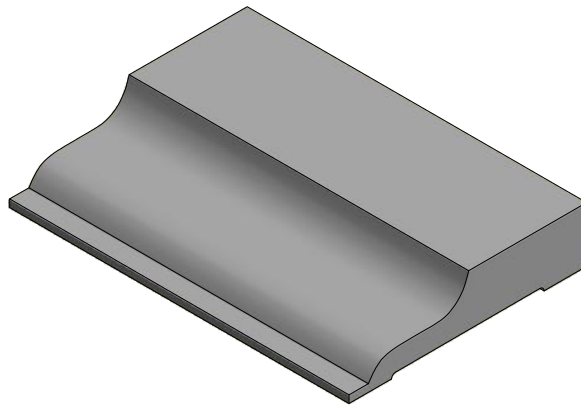
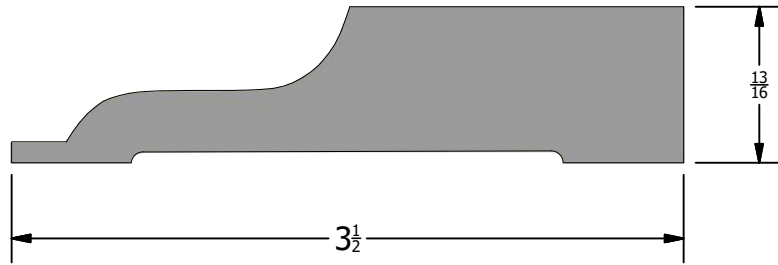

Description
Casing Base Board

Part Number
CB-11

-133-

Back

Scale 1 : 1



HOMESTEAD
WOODWORKS

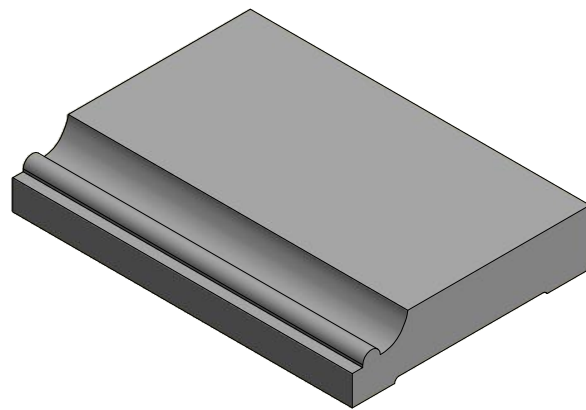
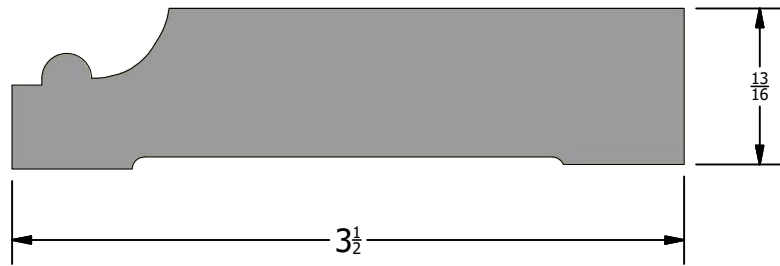

Description
Casing Base Board

Part Number
CB-12

-134-

Back

Scale 1 : 1



HOMESTEAD
WOODWORKS

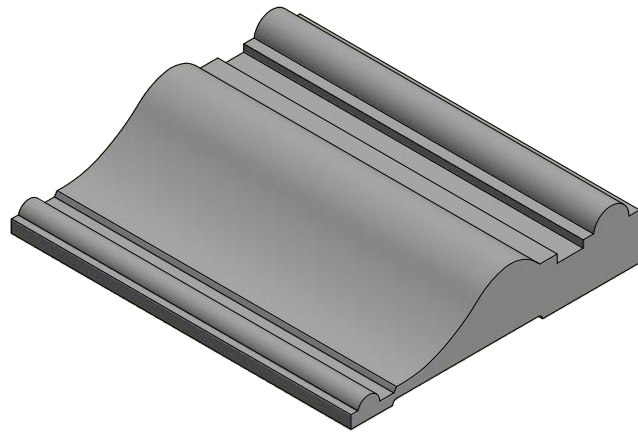
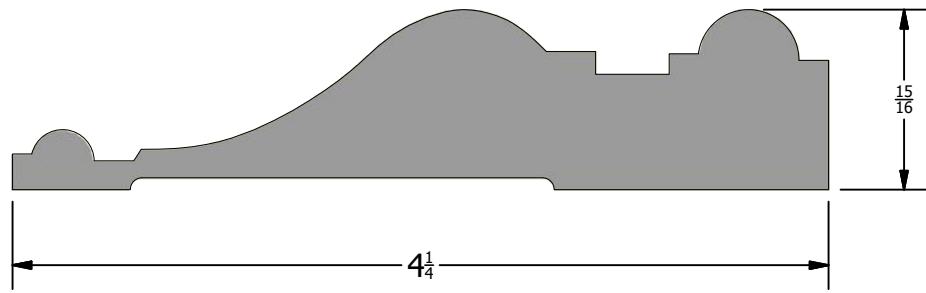

Description
Casing Base Board

Part Number
CB-13

-135-

Back

Scale 1 : 1



HOMESTEAD
WOODWORKS

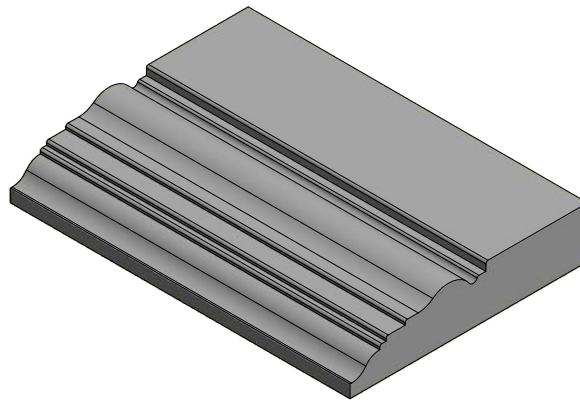
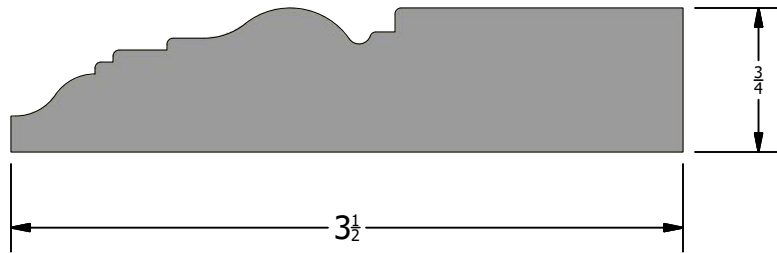

Description
Casing Base Board

Part Number
CB-14

-136-

Back

Scale 1 : 1



HOMESTEAD
WOODWORKS

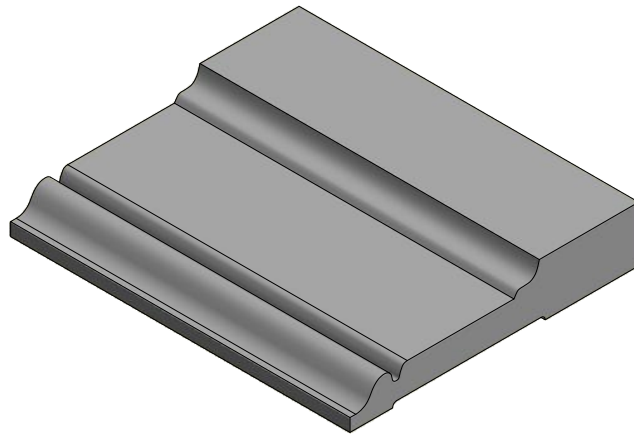
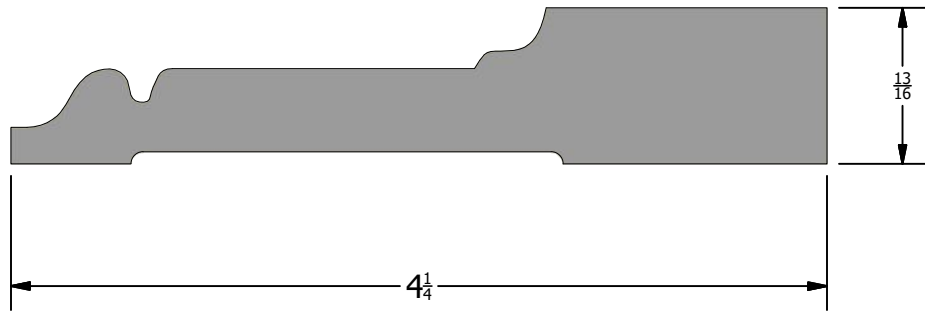

Description
Casing Base Board

Part Number
CB-15

-137-

Back

Scale 1 : 1



HOMESTEAD
WOODWORKS

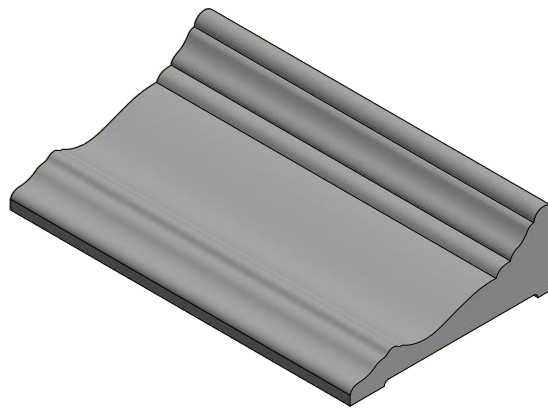
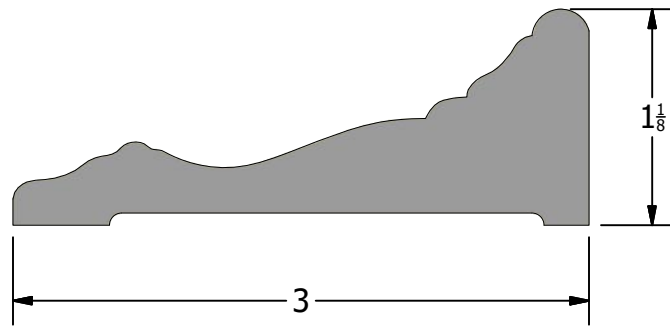

Description
Casing Base Board

Part Number
CB-16



-138-

Back

Scale 1 : 1

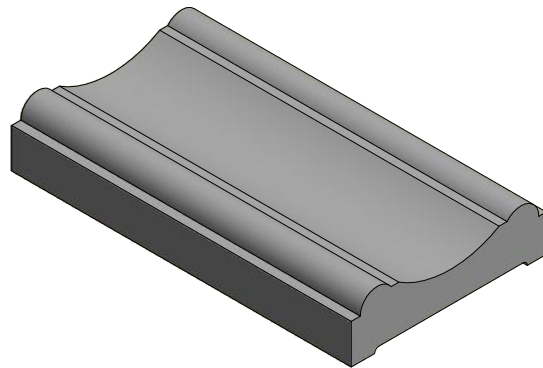
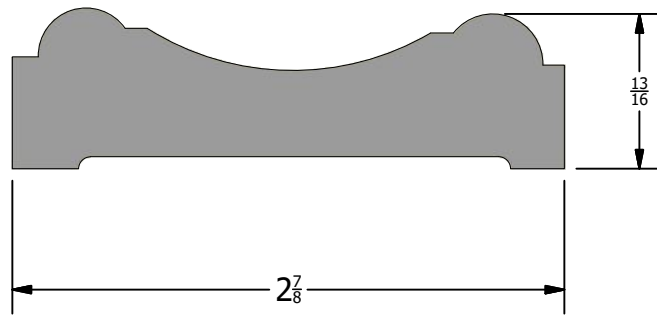

Description
Casing Base Board

Part Number
CB-17

-139-

Back

Scale 1 : 1



HOMESTEAD
WOODWORKS

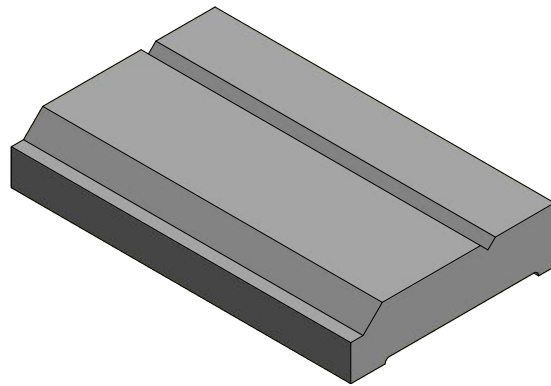
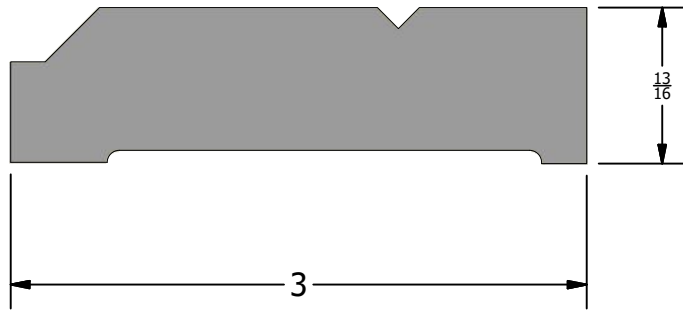

Description
Casing Base Board

Part Number
CB-18

-140-

Back

Scale 1 : 1



HOMESTEAD
WOODWORKS

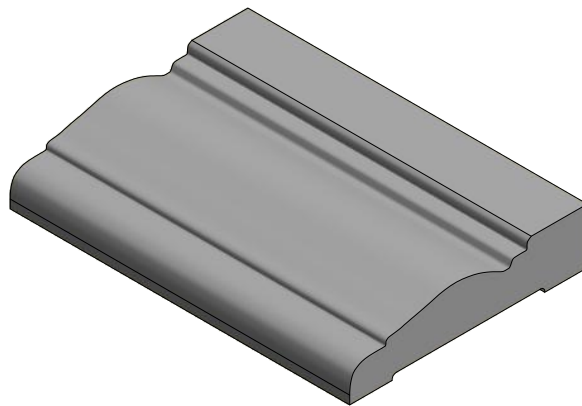
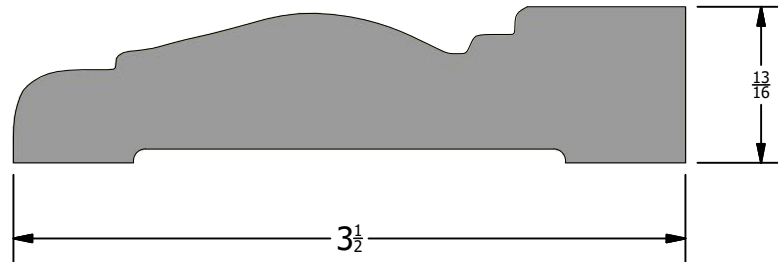

Description
Casing Base Board

Part Number
CB-19

-141-

Back

Scale 1 : 1



HOMESTEAD
WOODWORKS

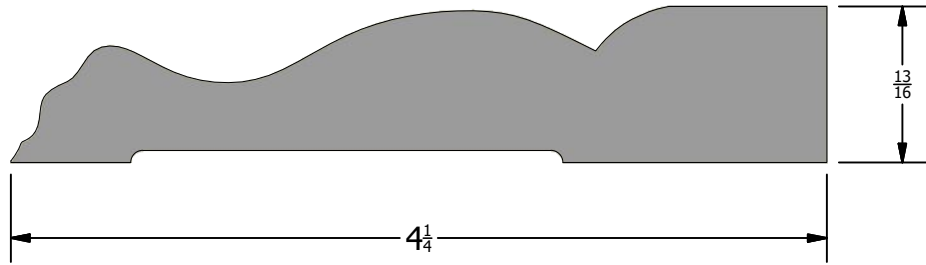

Description
Casing Base Board

Part Number
CB-20

-142-

Back

Scale 1 : 1



HOMESTEAD
WOODWORKS

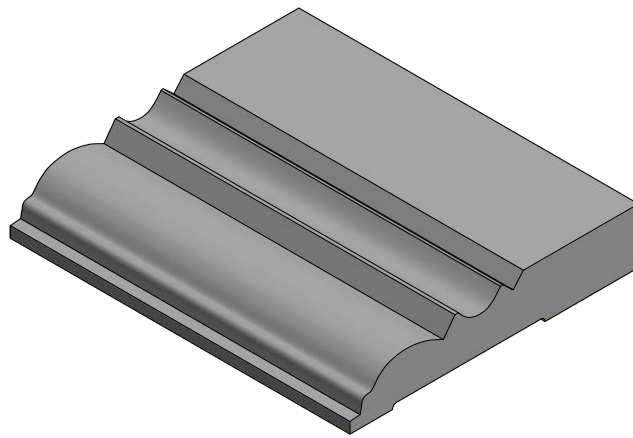
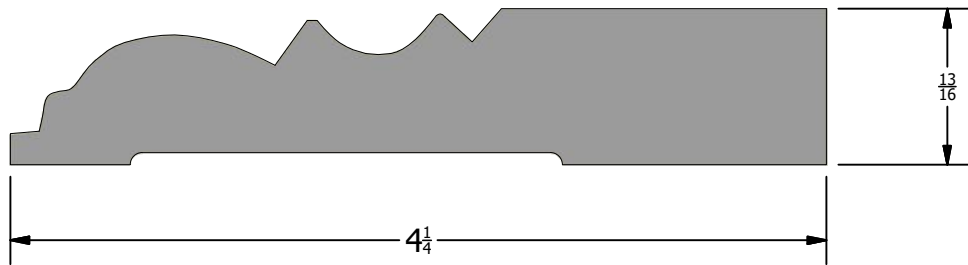

Description
Casing Base Board

Part Number
CB-21

-143-

Back

Scale 1 : 1



HOMESTEAD
WOODWORKS

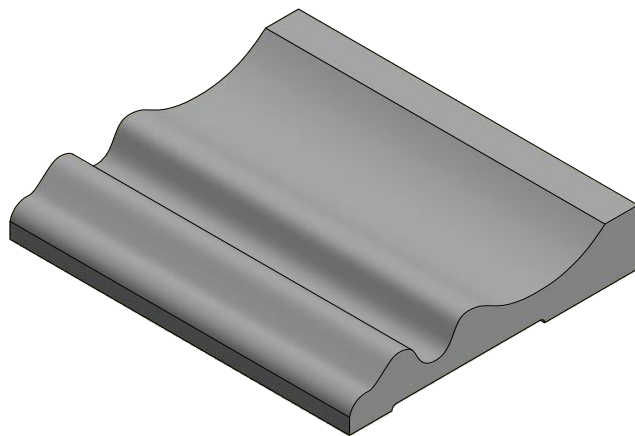
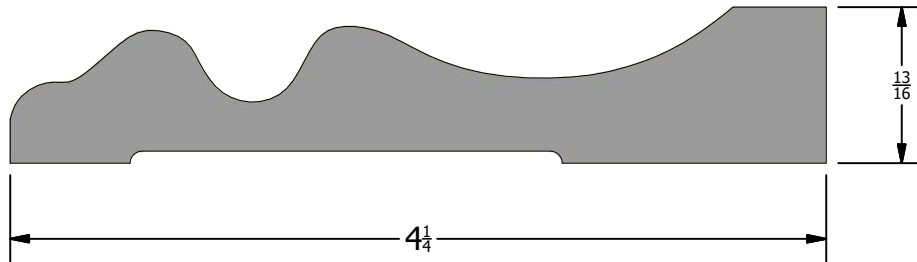

Description
Casing Base Board

Part Number
CB-22

-144-

Back

Scale 1 : 1



HOMESTEAD
WOODWORKS

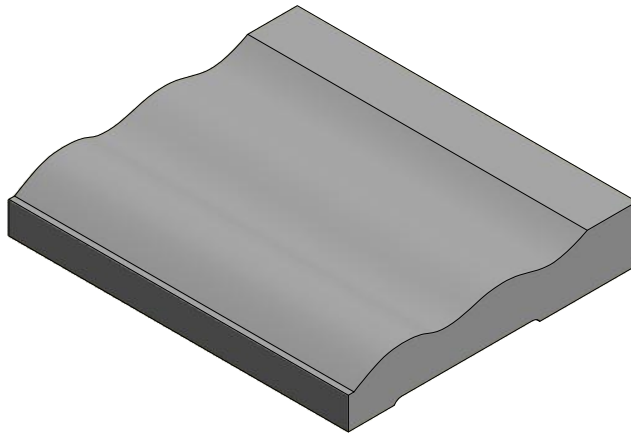
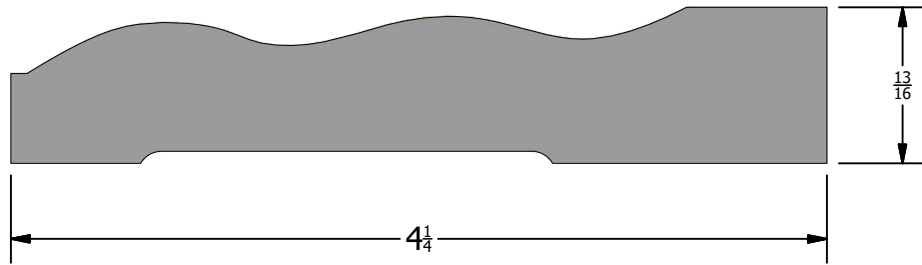

Description
Casing Base Board

Part Number
CB-23

-145-

Back

Scale 1 : 1



HOMESTEAD
WOODWORKS

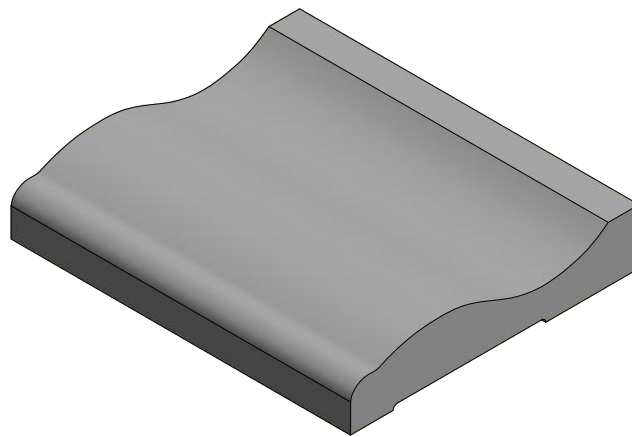
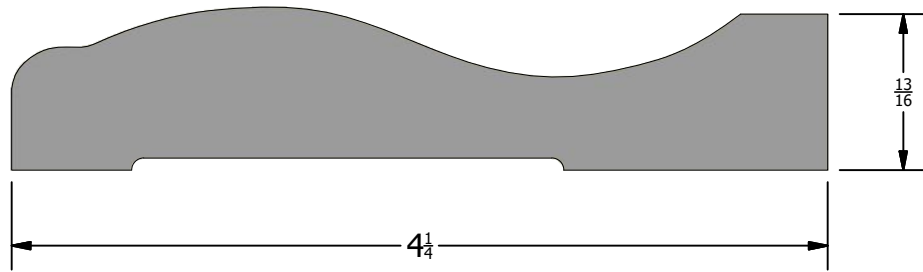

Description
Casing Base Board

Part Number
CB-24

-146-

Back

Scale 1 : 1



HOMESTEAD
WOODWORKS

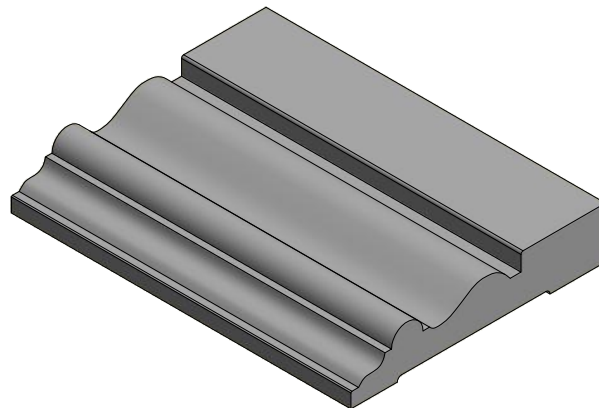
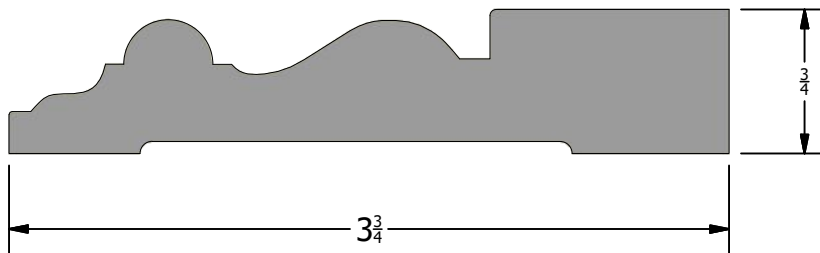

Description
Casing Base Board

Part Number
CB-25

-147-

Back

Scale 1 : 1



HOMESTEAD
WOODWORKS

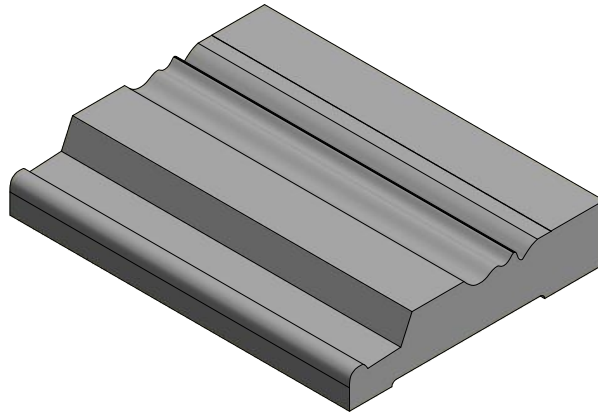
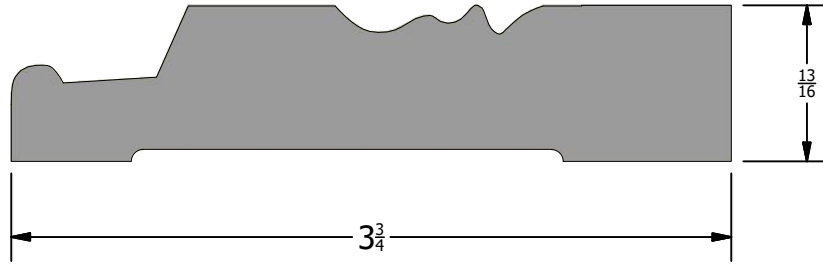

Description
Casing Base Board

Part Number
CB-26

-148-

Back

Scale 1 : 1



HOMESTEAD
WOODWORKS

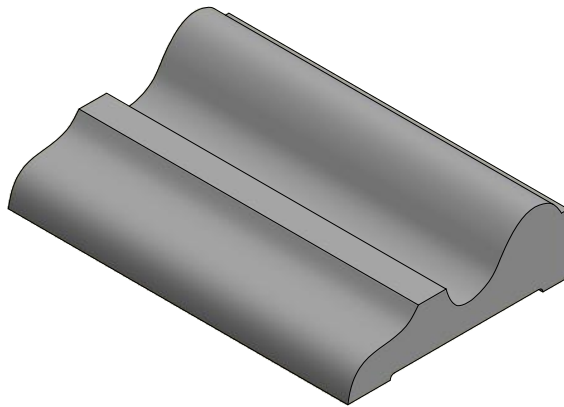
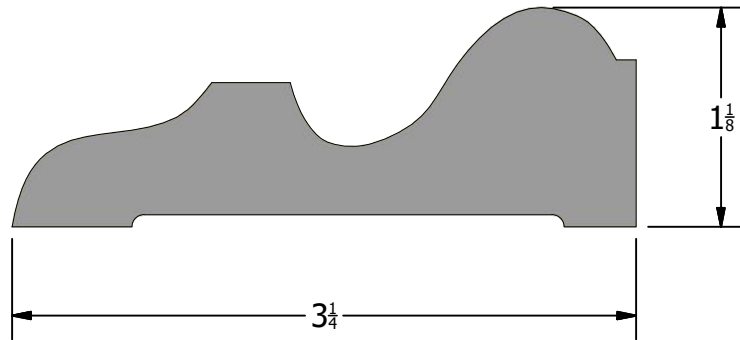

Description
Casing Base Board

Part Number
CB-27

-149-

Back

Scale 1 : 1



HOMESTEAD
WOODWORKS

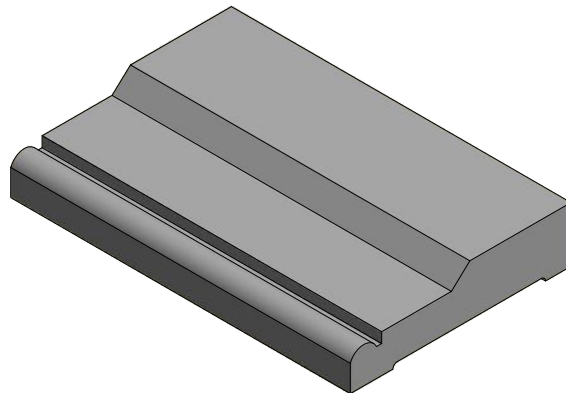
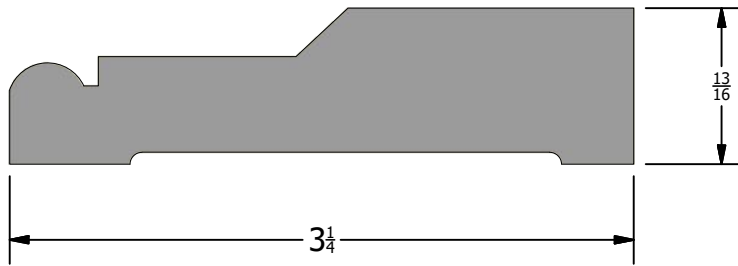

Description
Casing Base Board

Part Number
CB-28 -A

-150-

Back

Scale 1 : 1



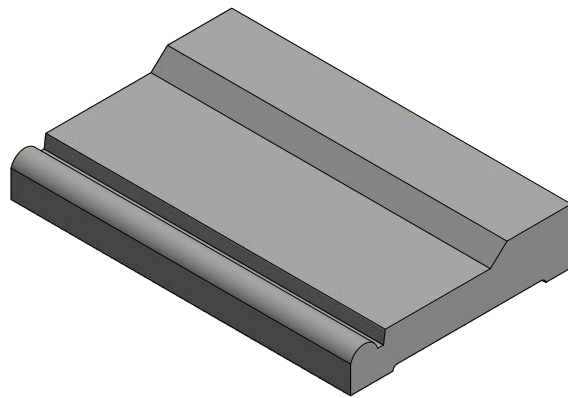
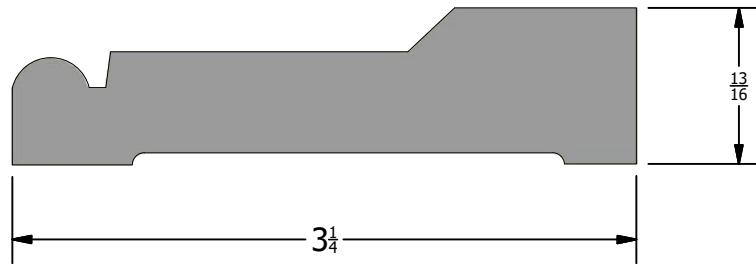

Description
Casing Base Board

Part Number
CB-28-B

-151-

Back

Scale 1 : 1



HOMESTEAD
WOODWORKS

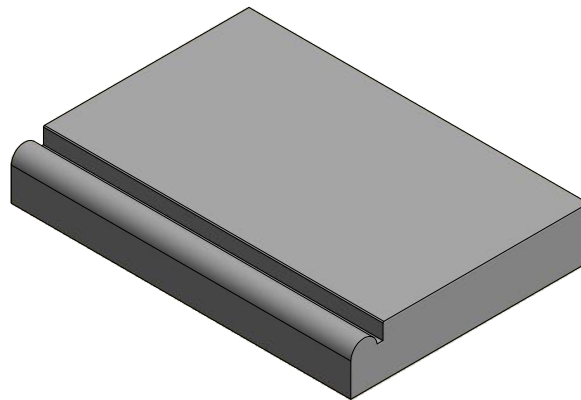
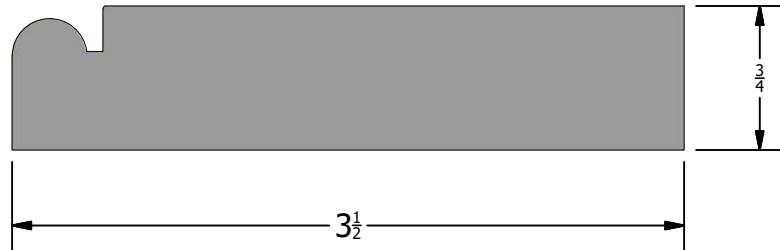

Description
Casing Base Board

Part Number
CB-28-C

-152-

Back

Scale 1 : 1



HOMESTEAD
WOODWORKS

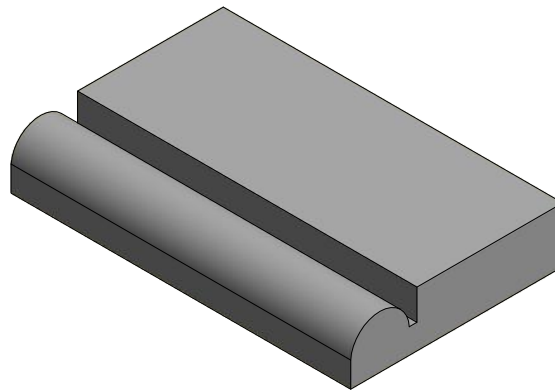
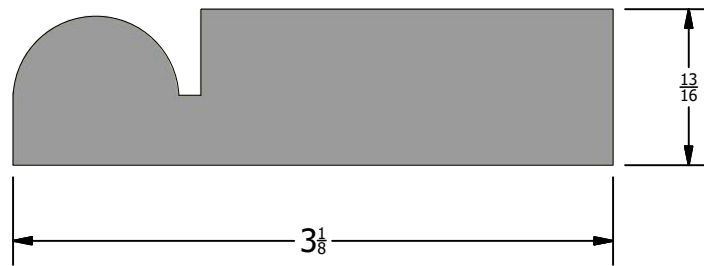

Description
Casing Base Board

Part Number
CB-28-D

-153-

Back

Scale 1 : 1



HOMESTEAD
WOODWORKS

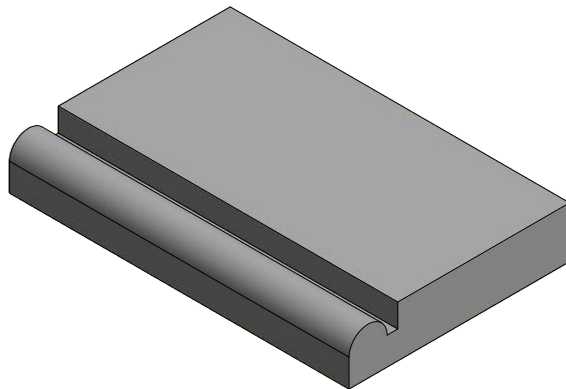
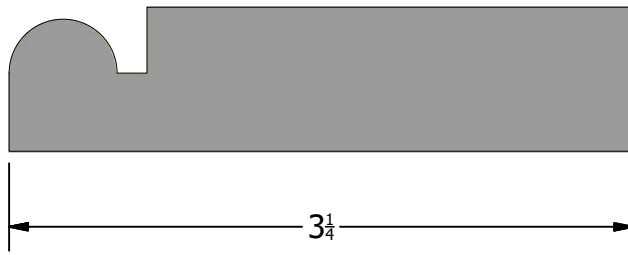

Description
Casing Base Board

Part Number
CB-28-E

-154-

Back

Scale 1 : 1



HOMESTEAD
WOODWORKS

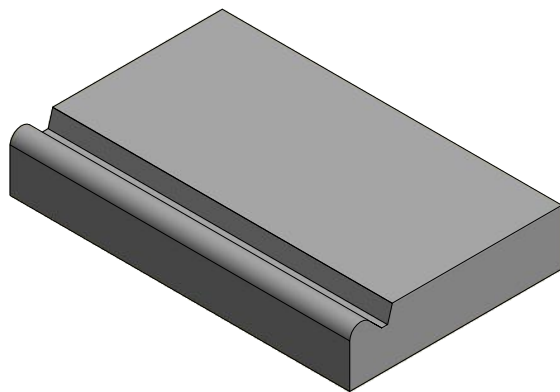
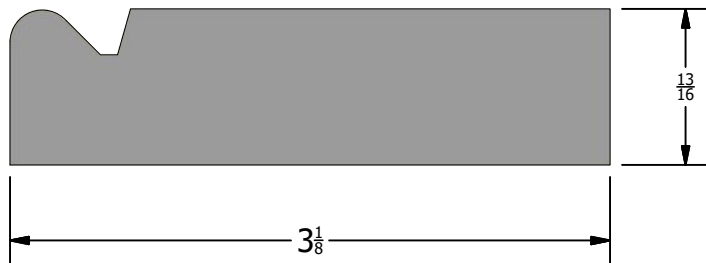

Description
Casing Base Board

Part Number
CB-29

-155-

Back

Scale 1 : 1



HOMESTEAD
WOODWORKS

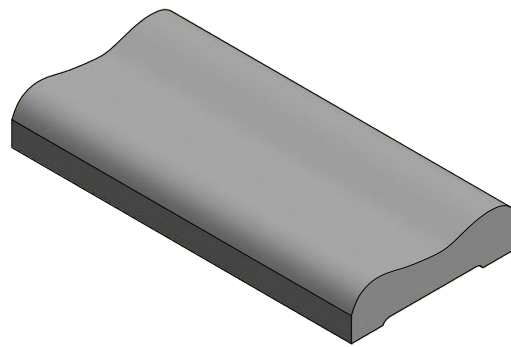
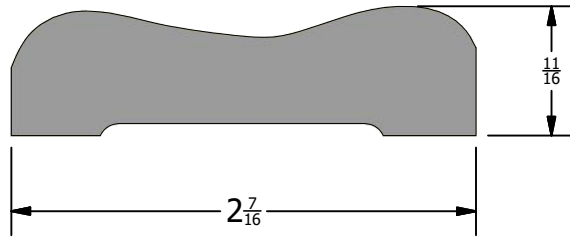

Description
Casing Base Board

Part Number
CB-30

-156-

Back

Scale 1 : 1



HOMESTEAD
WOODWORKS

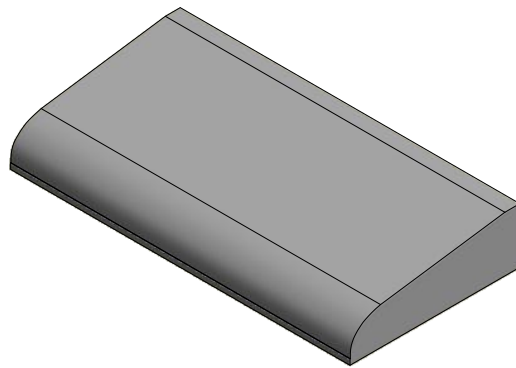
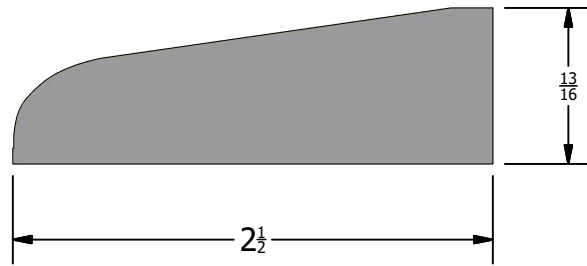

Description
Casing Base Board

Part Number
CB-31

-157-

Back

Scale 1 : 1



HOMESTEAD
WOODWORKS

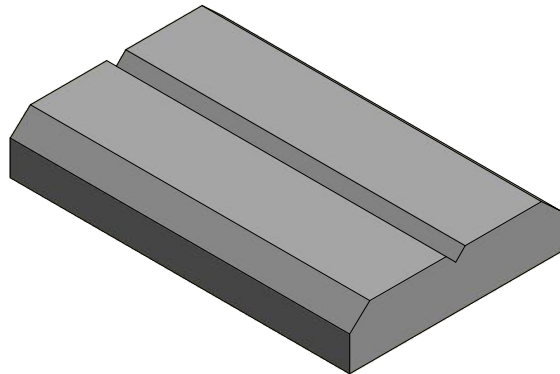
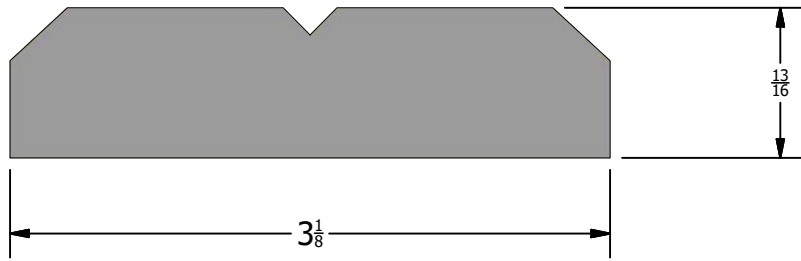

Description
Casing Base Board

Part Number
CB-32

-158-

Back

Scale 1 : 1



HOMESTEAD
WOODWORKS

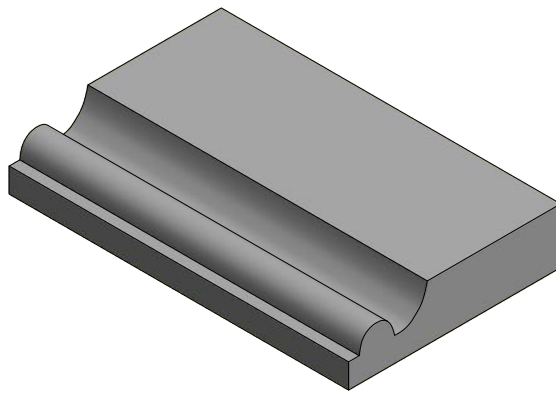
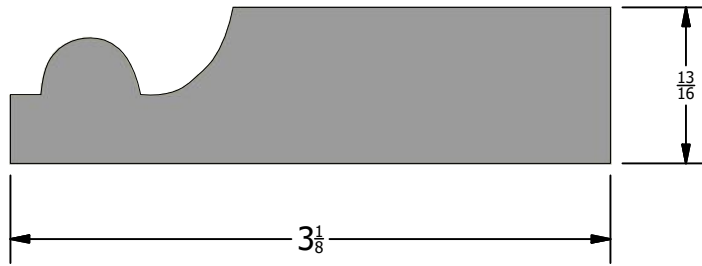

Description
Casing Base Board

Part Number
CB-33

-159-

Back

Scale 1 : 1



HOMESTEAD
WOODWORKS

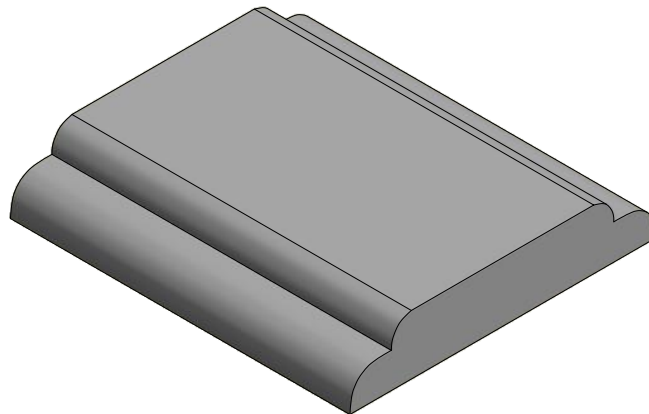
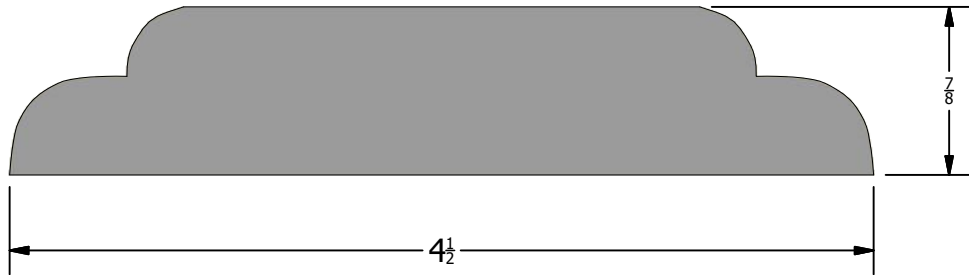

Description
Casing Base Board

Part Number
CB-34

-160-

Back

Scale 1 : 1



HOMESTEAD
WOODWORKS

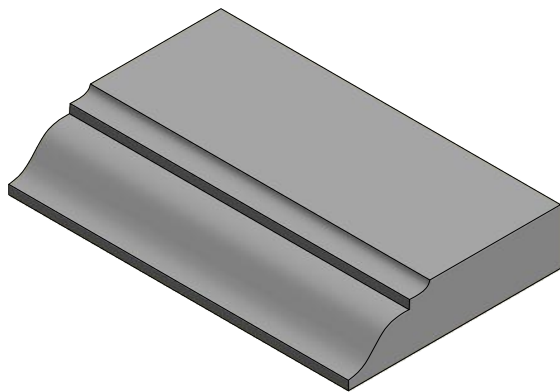
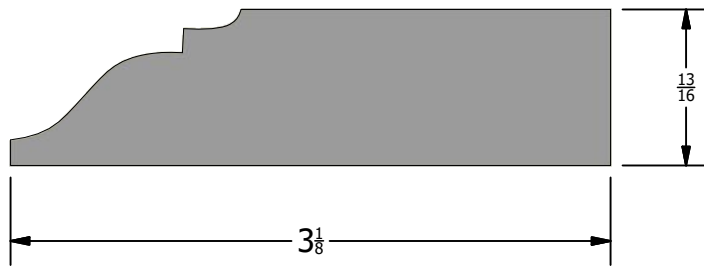

Description
Casing Base Board

Part Number
CB-35

-161-

Back

Scale 1 : 1



HOMESTEAD
WOODWORKS

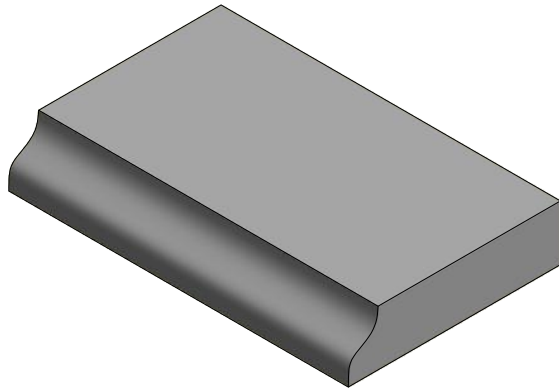
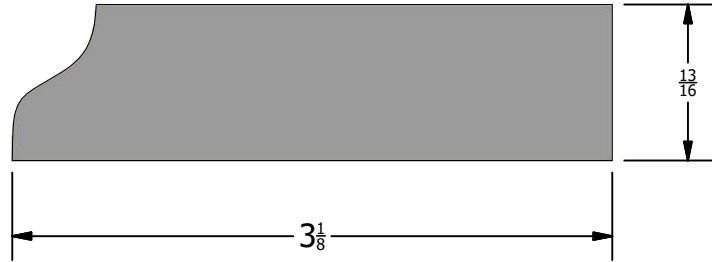

Description
Casing Base Board

Part Number
CB-36

-162-

Back

Scale 1 : 1



HOMESTEAD
WOODWORKS

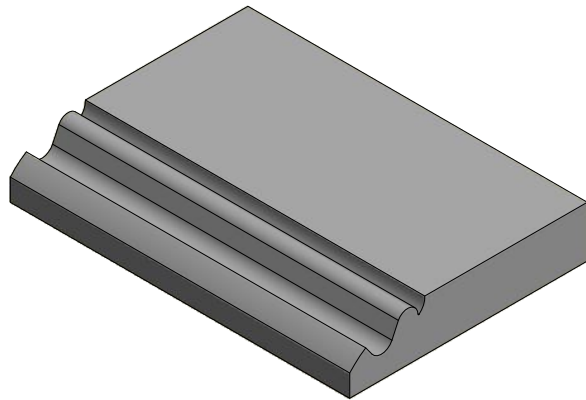
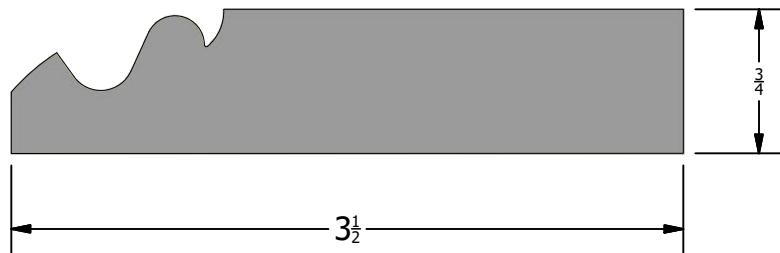

Description
Casing Base Board

Part Number
CB-37

-163-

Back

Scale 1 : 1



HOMESTEAD
WOODWORKS

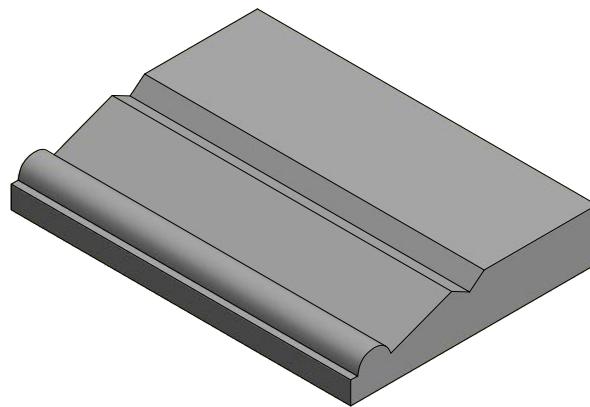
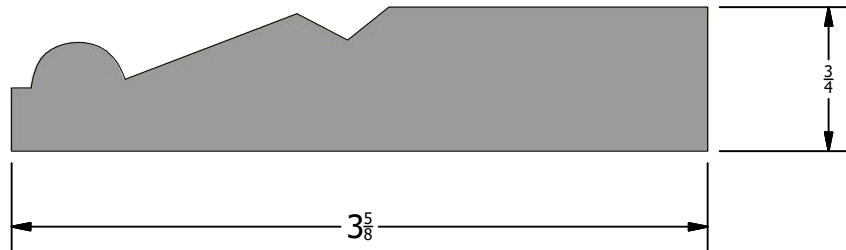

Description
Casing Base Board

Part Number
CB-38

-164-

Back

Scale 1 : 1



HOMESTEAD
WOODWORKS

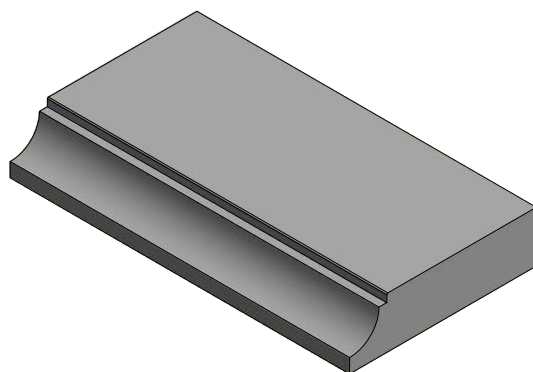
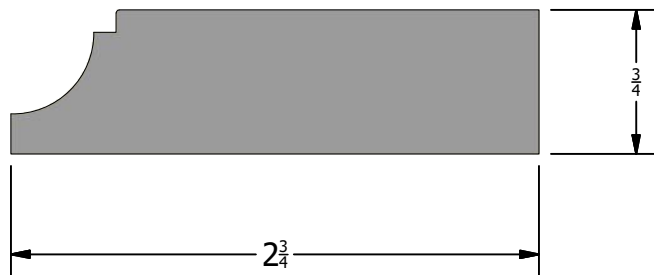

Description
Casing Base Board

Part Number
CB-39

-165-

Back

Scale 1 : 1

HOMESTEAD
WOODWORKS

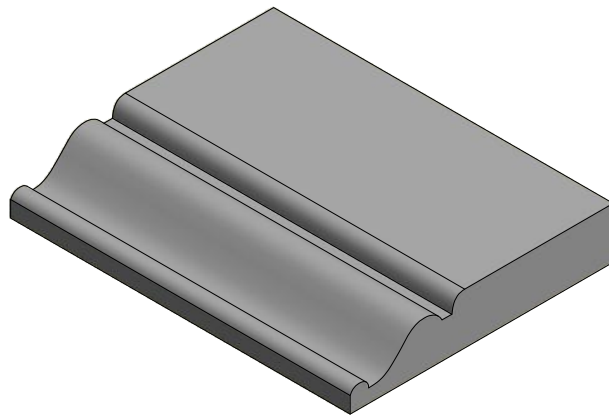
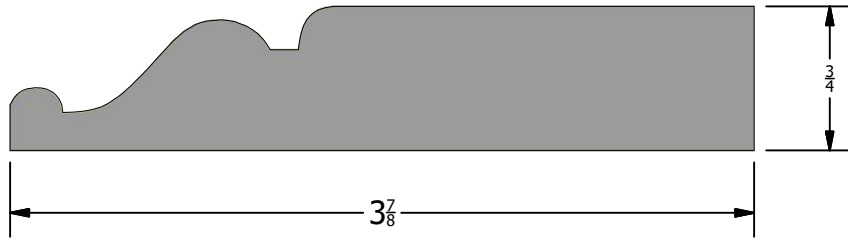

Description
Casing Base Board

Part Number
CB-40

-166-

Back

Scale 1 : 1



HOMESTEAD
WOODWORKS

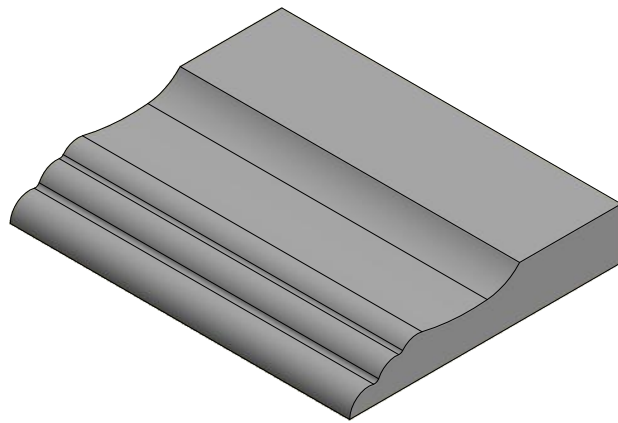
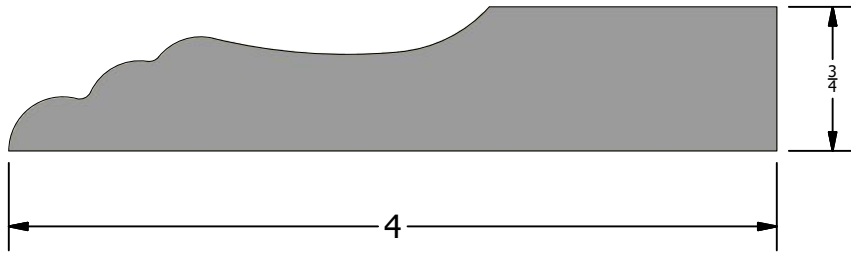

Description Casing Base Board		Part Number CB-41	 HOMESTEAD WOODWORKS
-167-	Back	Scale 1 : 1	

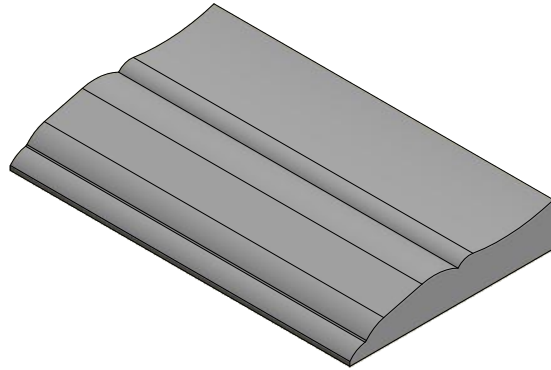
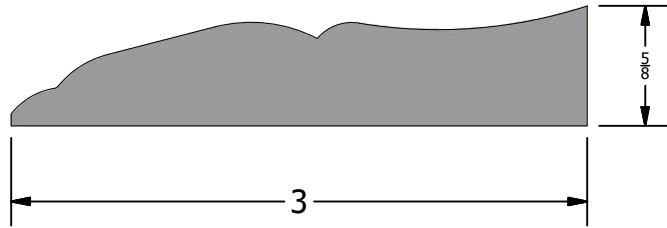

Description
Casing Base Board

Part Number
CB-42

-168-

Back

Scale 1 : 1



HOMESTEAD
WOODWORKS

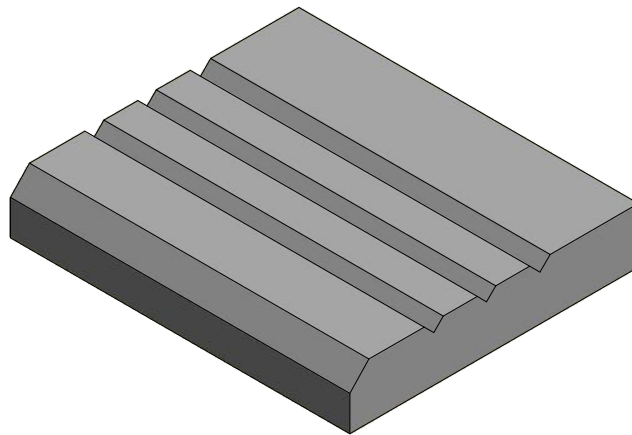
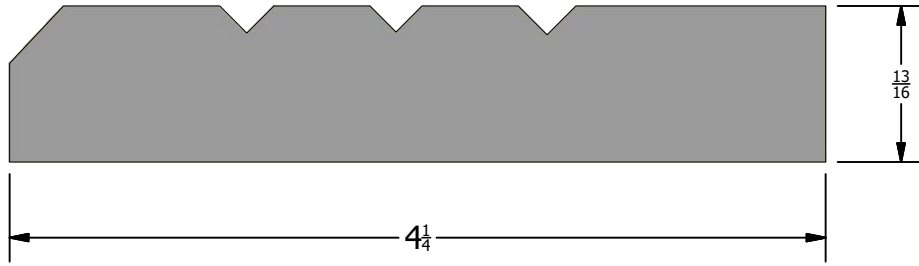

Description
Casing Base Board

Part Number
CB-43

-169-

Back

Scale 1 : 1



HOMESTEAD
WOODWORKS

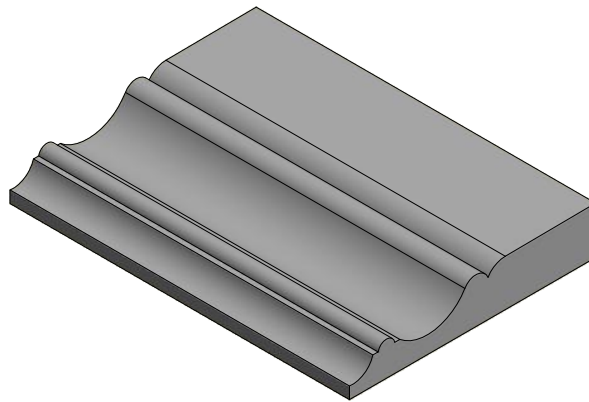
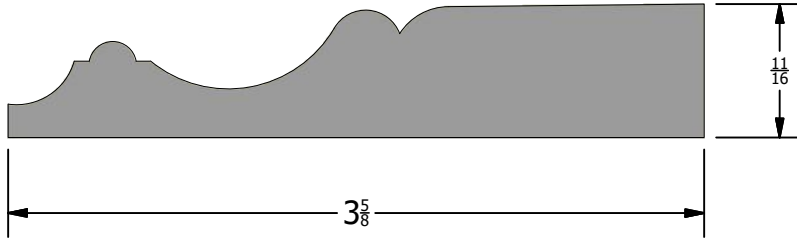

Description
Casing Base Board

Part Number
CB-44

-170-

Back

Scale 1 : 1



HOMESTEAD
WOODWORKS

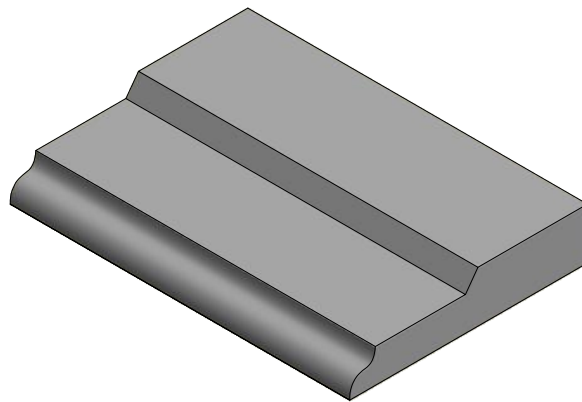
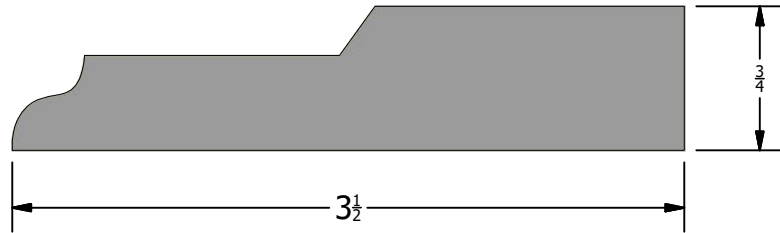

Description
Casing Base Board

Part Number
CB-45

-171-

Back

Scale 1 : 1



HOMESTEAD
WOODWORKS

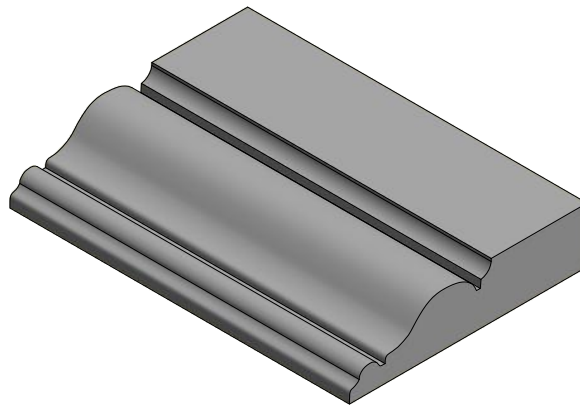
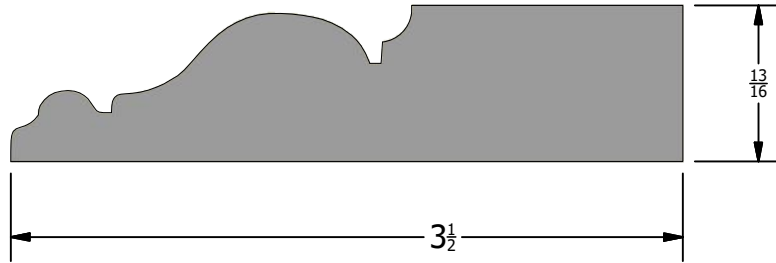

Description
Casing Base Board

Part Number
CB-46

-172-

Back

Scale 1 : 1



HOMESTEAD
WOODWORKS

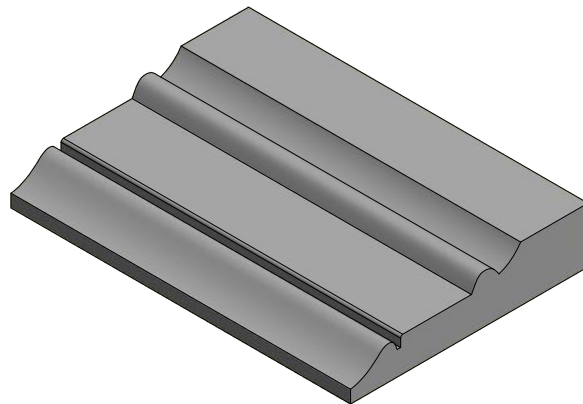
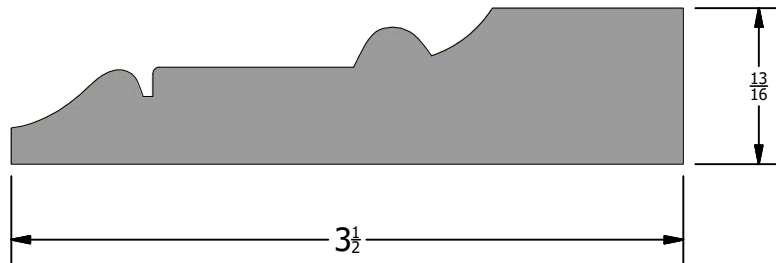

Description
Casing Base Board

Part Number
CB-47

-173-

Back

Scale 1 : 1



HOMESTEAD
WOODWORKS

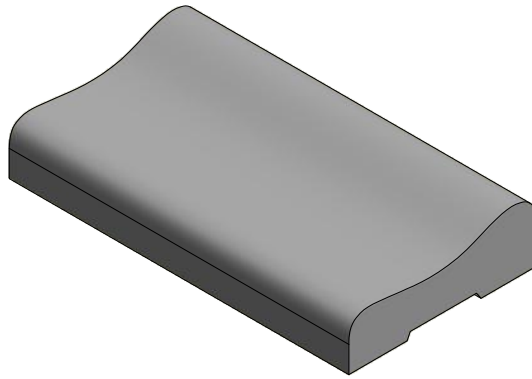
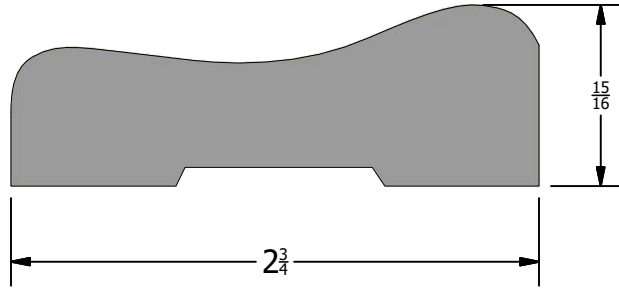

Description
Casing Base Board

Part Number
CB-48-A

-174-

Back

Scale 1 : 1



HOMESTEAD
WOODWORKS

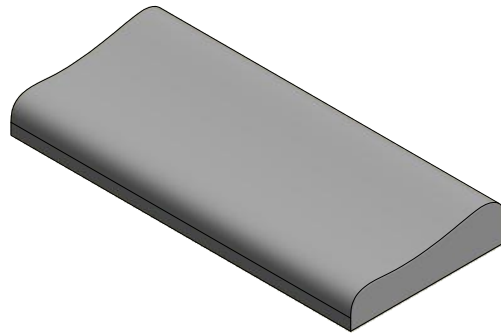
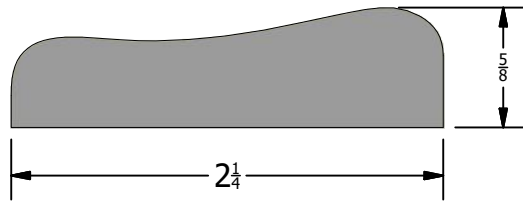

Description
Casing Base Board

Part Number
CB-48-B

-175-

Back

Scale 1 : 1



HOMESTEAD
WOODWORKS

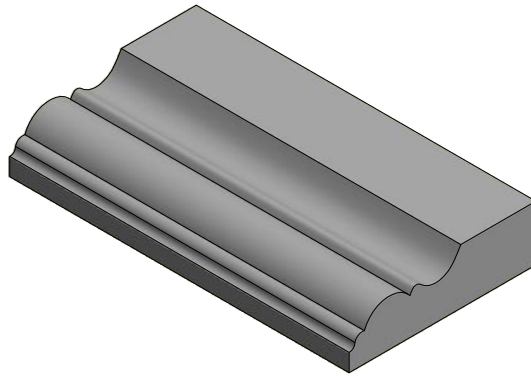
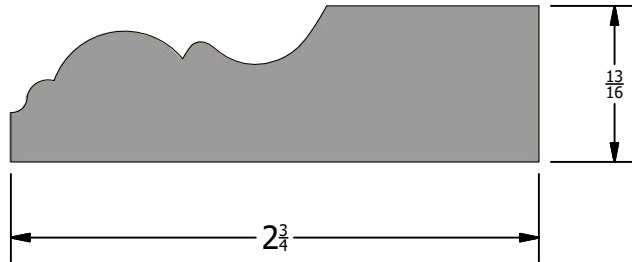

Description
Casing Base Board

Part Number
CB-49

-176-

Back

Scale 1 : 1



HOMESTEAD
WOODWORKS

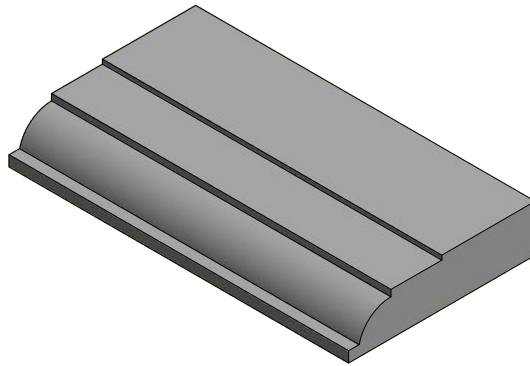
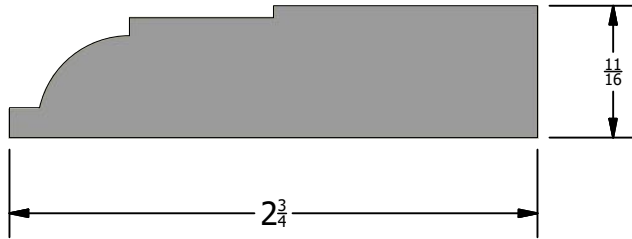

Description
Casing Base Board

Part Number
CB-50

-177-

Back

Scale 1 : 1



HOMESTEAD
WOODWORKS

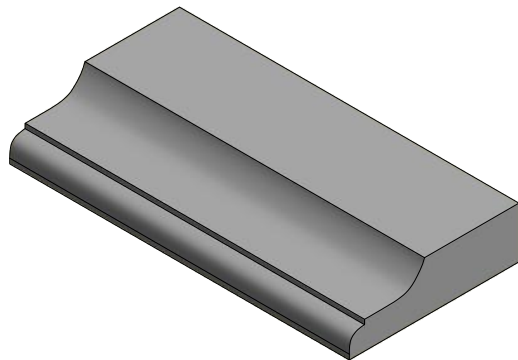
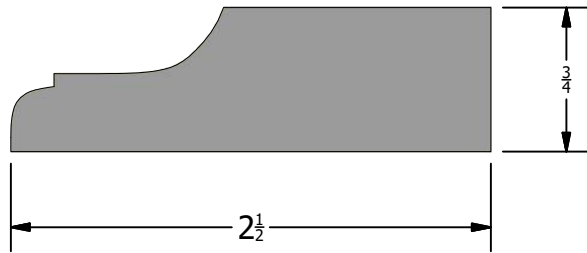

Description
Casing Base Board

Part Number
CB-51

-178-

Back

Scale 1 : 1



HOMESTEAD
WOODWORKS

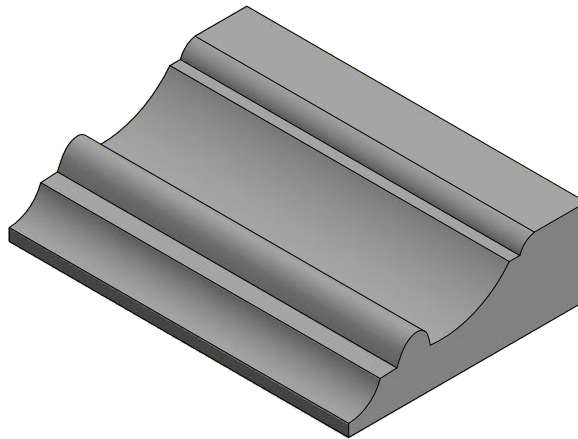
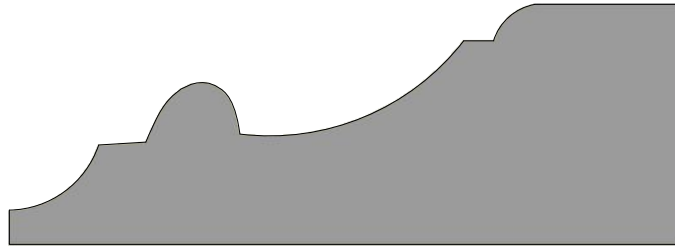

Description
Casing Base Board

Part Number
CB-52

-179-

Back

Scale 1 : 1



HOMESTEAD
WOODWORKS

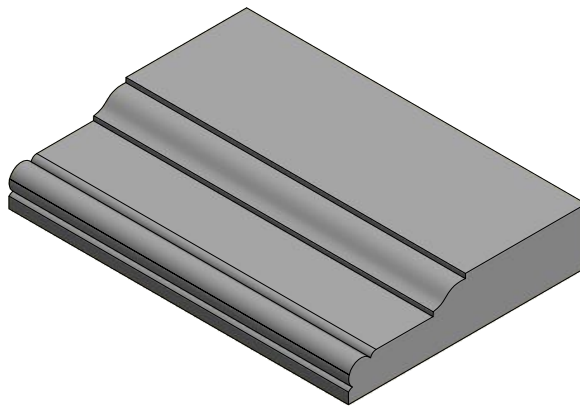
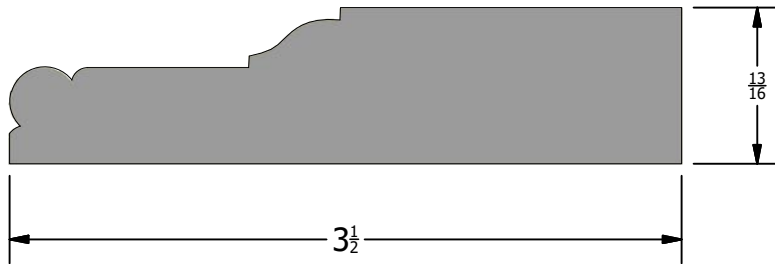

Description
Casing Base Board

Part Number
CB-53-A



-180-

Back

Scale 1 : 1

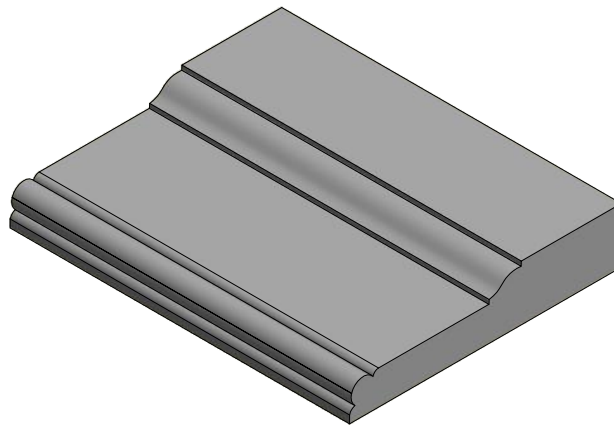
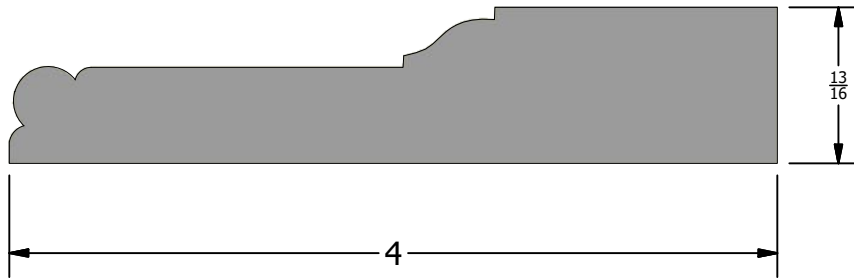

Description
Casing Base Board

Part Number
CB-53-B

-181-

Back

Scale 1 : 1



HOMESTEAD
WOODWORKS

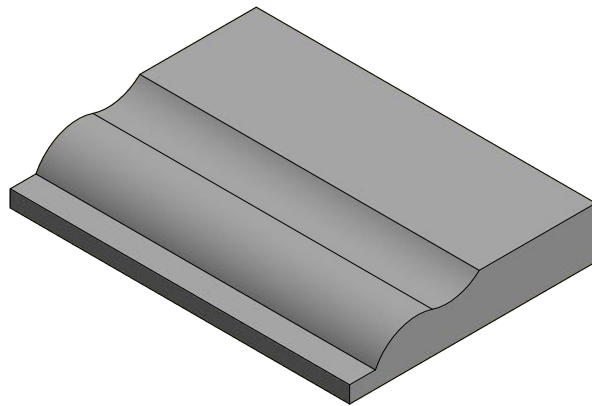
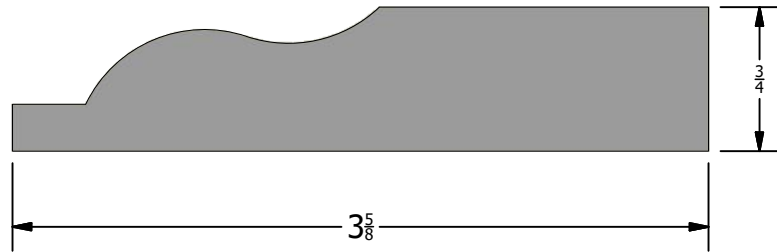

Description
Casing Base Board

Part Number
CB-54

-182-

Back

Scale 1 : 1



HOMESTEAD
WOODWORKS

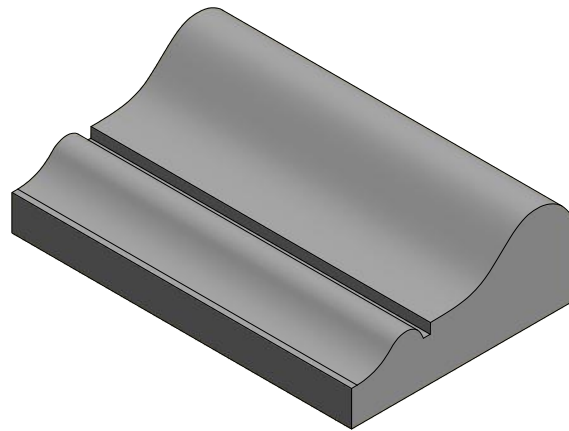
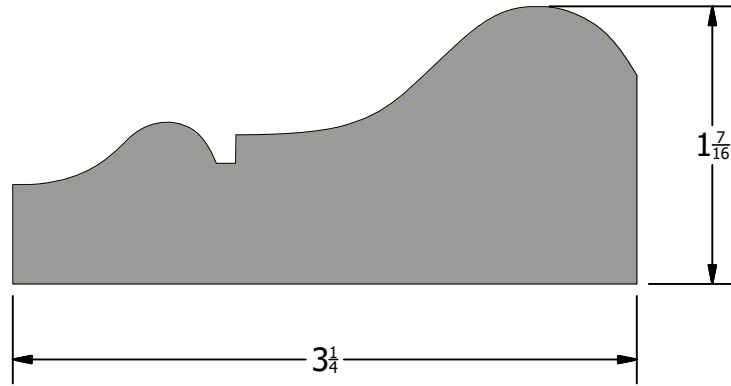

Description
Casing Base Board

Part Number
CB-55

-183-

Back

Scale 1 : 1



HOMESTEAD
WOODWORKS

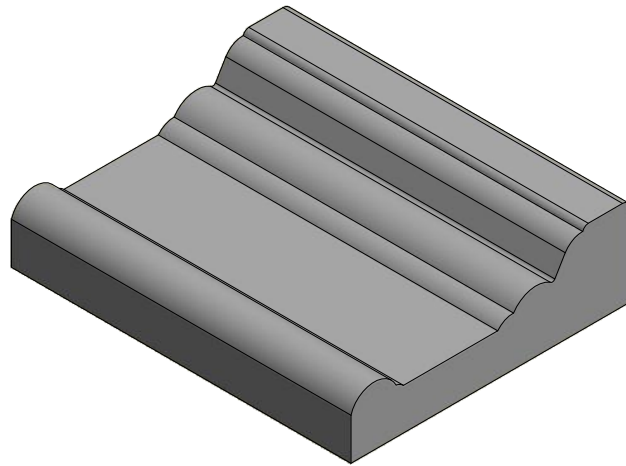
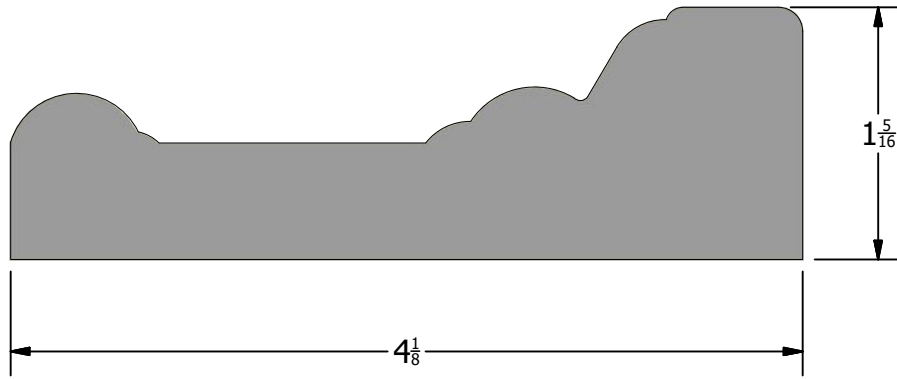

Description
Casing Base Board

Part Number
CB-56

-184-

Back

Scale 1 : 1



HOMESTEAD
WOODWORKS

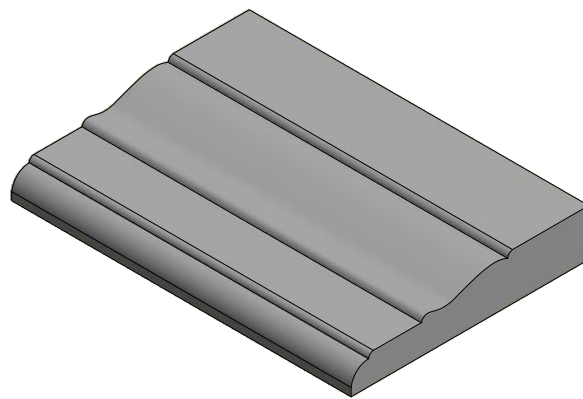
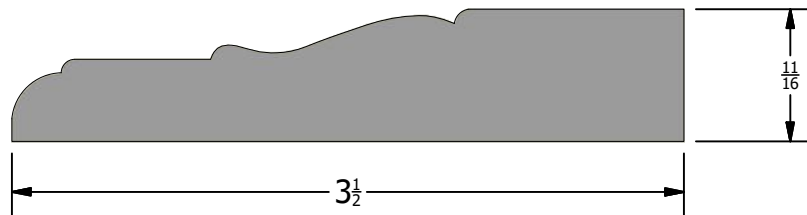

Description
Casing Base Board

Part Number
CB-57

-185-

Back

Scale 1 : 1



HOMESTEAD
WOODWORKS

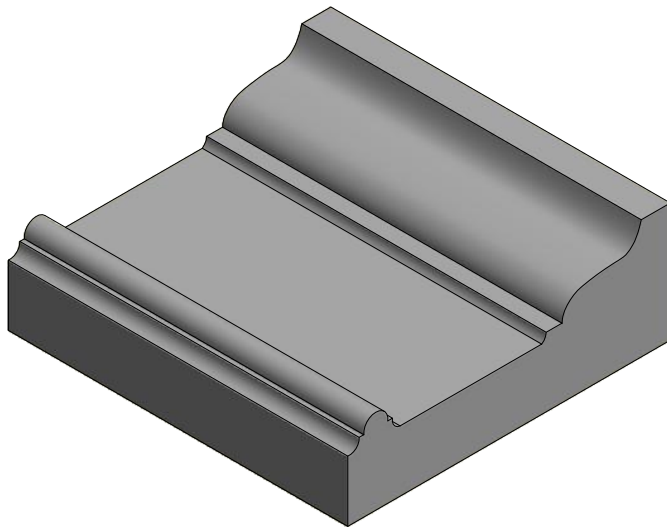
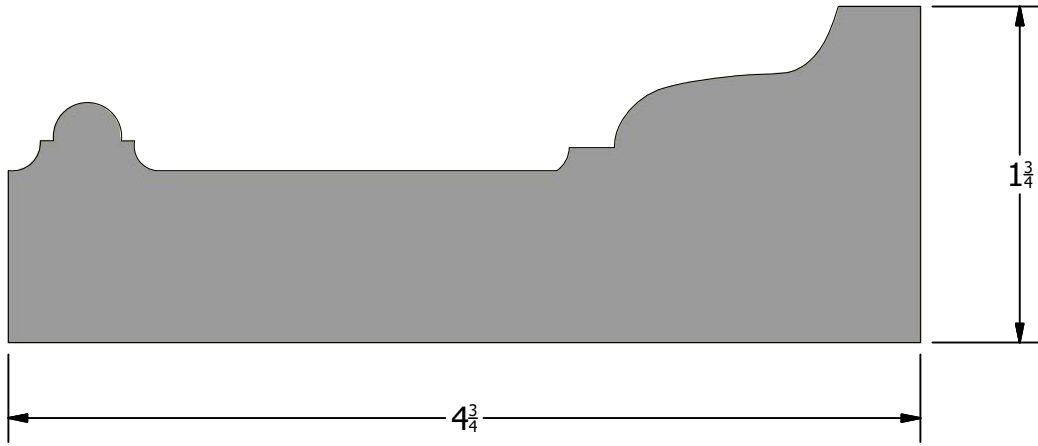

Description
Casing Base Board

Part Number
CB-58

-186-

Back

Scale 1 : 1



HOMESTEAD
WOODWORKS

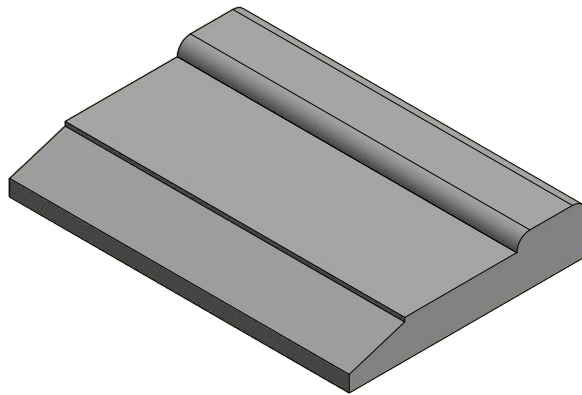
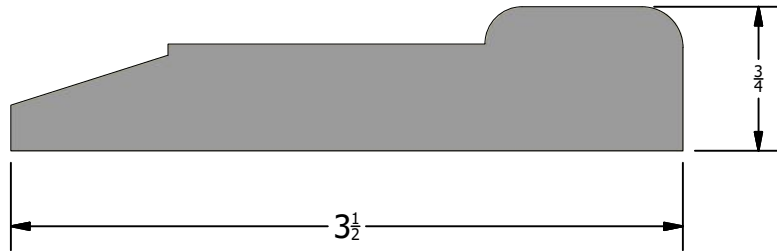

Description
Casing Base Board

Part Number
CB-59

-187-

Back

Scale 1 : 1



HOMESTEAD
WOODWORKS

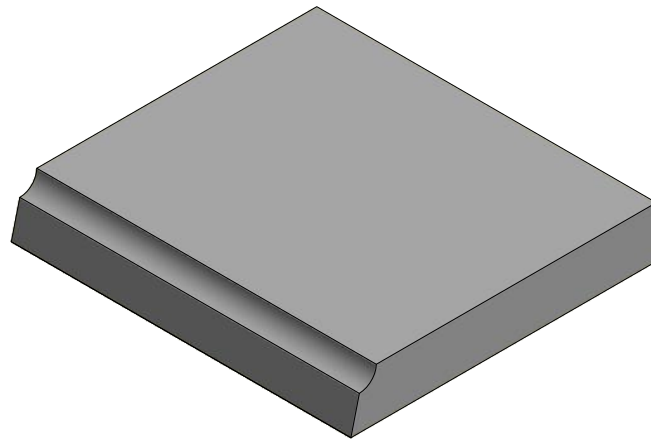
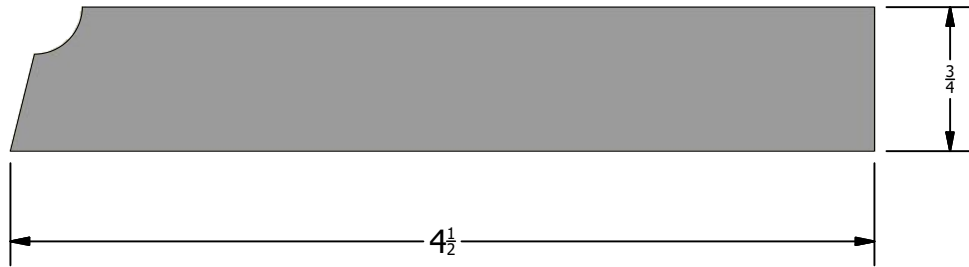

Description
Casing Base Board

Part Number
CB-60

-188-

Back

Scale 1 : 1



HOMESTEAD
WOODWORKS

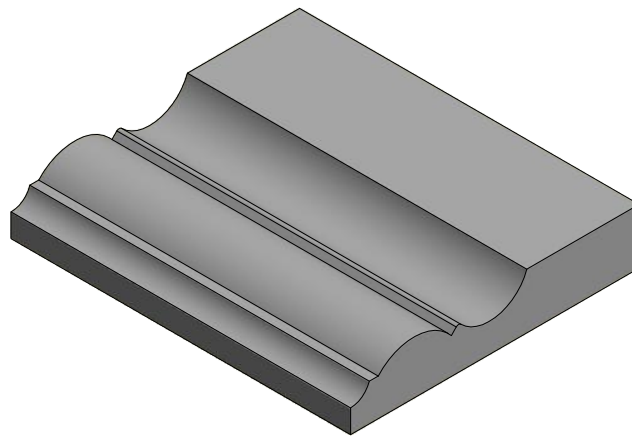
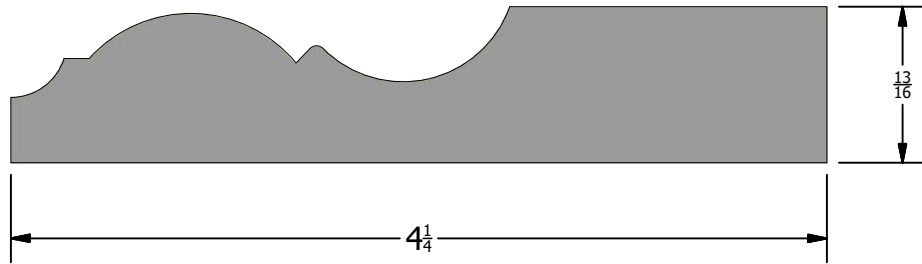

Description
Casing Base Board

Part Number
CB-61

-189-

Back

Scale 1 : 1



HOMESTEAD
WOODWORKS

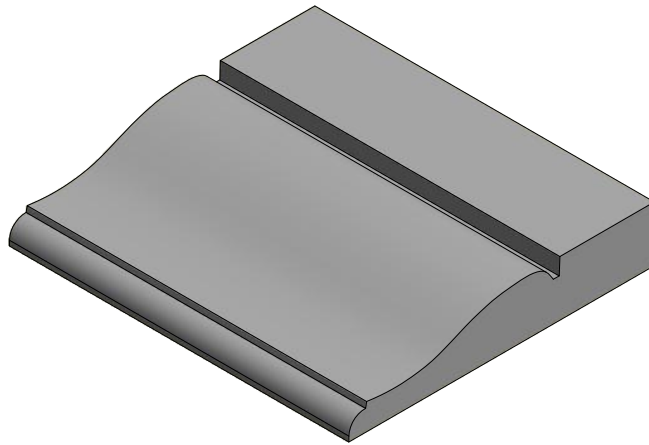
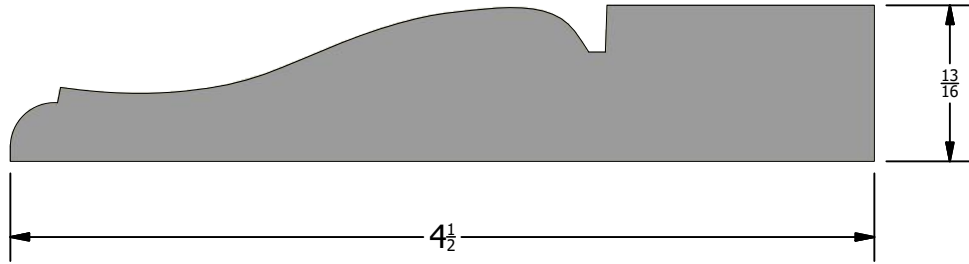

Description
Casing Base Board

Part Number
CB-62



-190-

Back

Scale 1 : 1

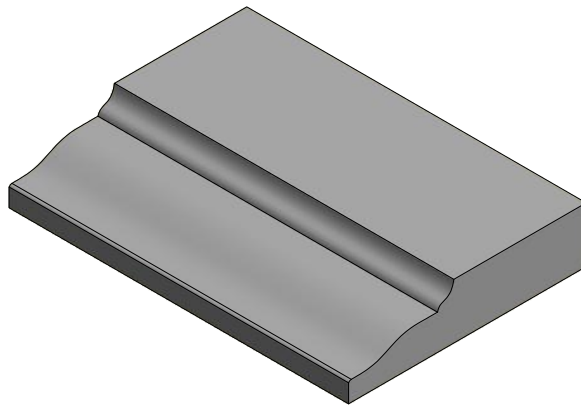
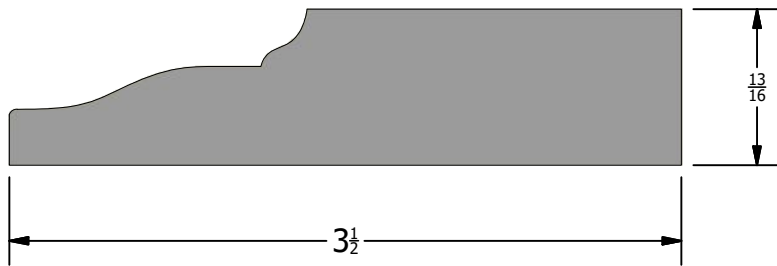

Description
Casing Base Board

Part Number
CB-63

-191-

Back

Scale 1 : 1



HOMESTEAD
WOODWORKS

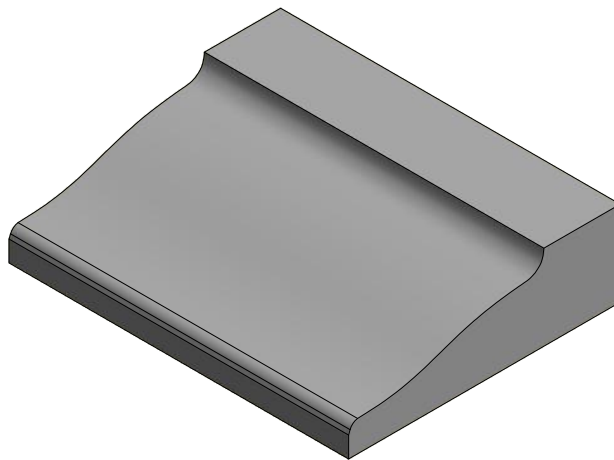
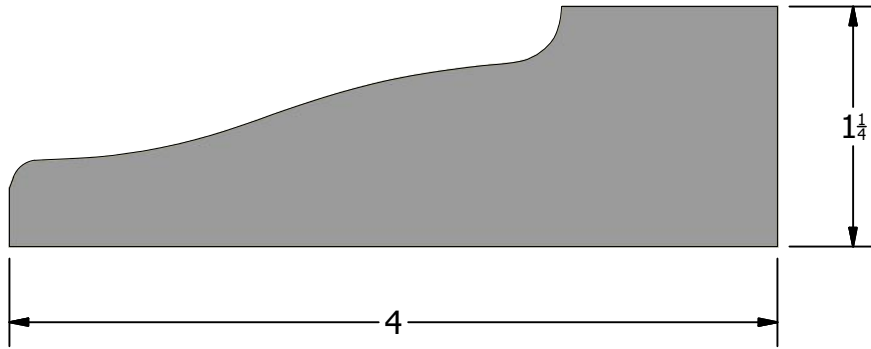

Description
Casing Base Board

Part Number
CB-64

-192-

Back

Scale 1 : 1



HOMESTEAD
WOODWORKS

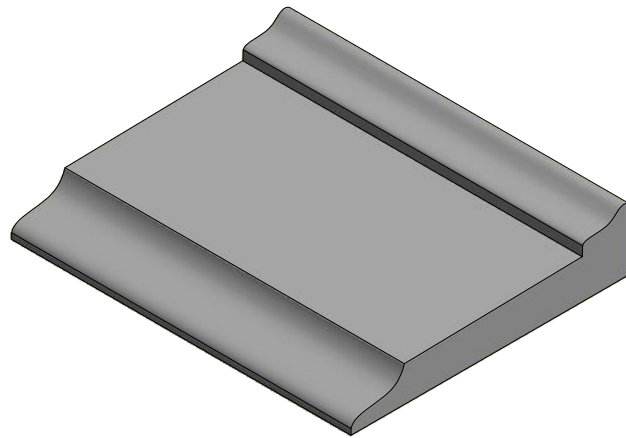
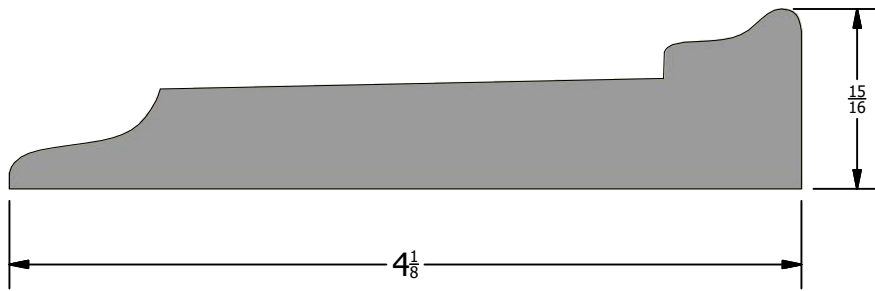

Description
Casing Base Board

Part Number
CB-65

-193-

Back

Scale 1 : 1



HOMESTEAD
WOODWORKS

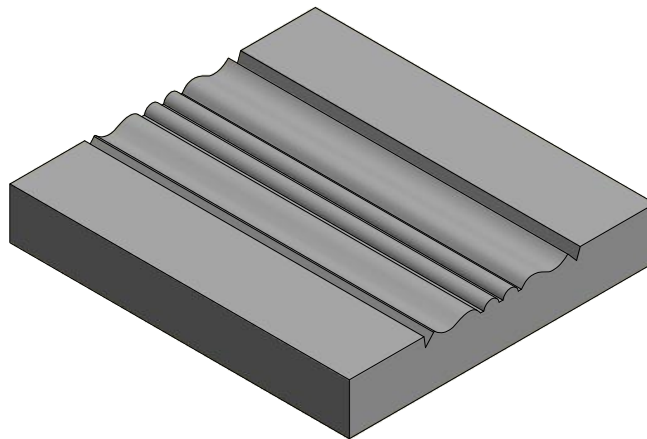
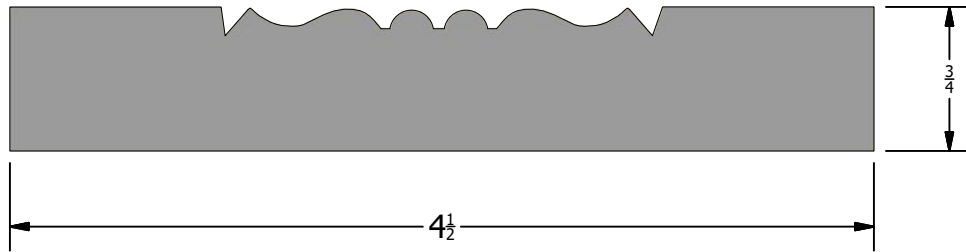

Description
Casing Base Board

Part Number
CB-67

-194-

Back

Scale 1 : 1



HOMESTEAD
WOODWORKS

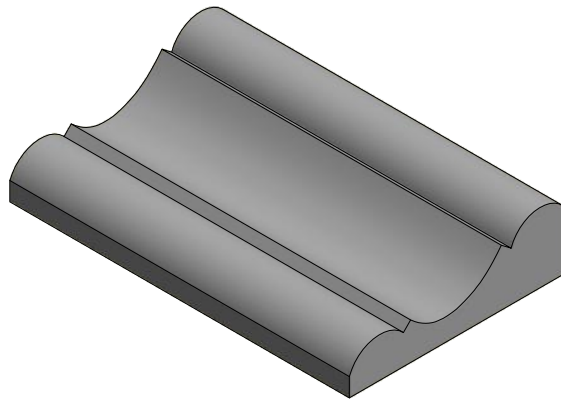
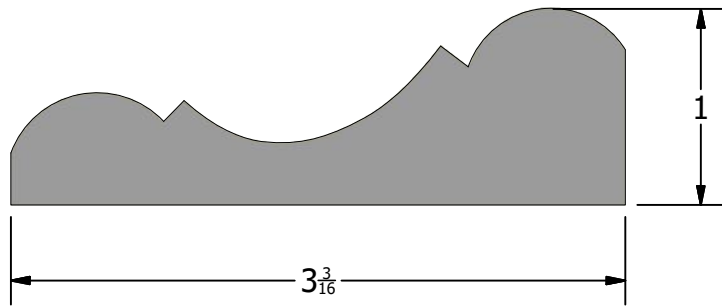

Description
Casing Base Board

Part Number
CB-68

-195-

Back

Scale 1 : 1



HOMESTEAD
WOODWORKS

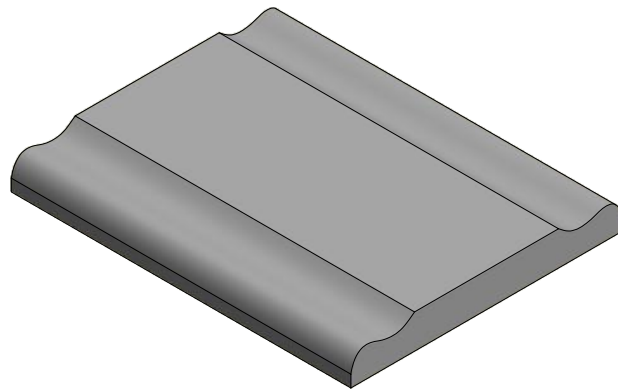
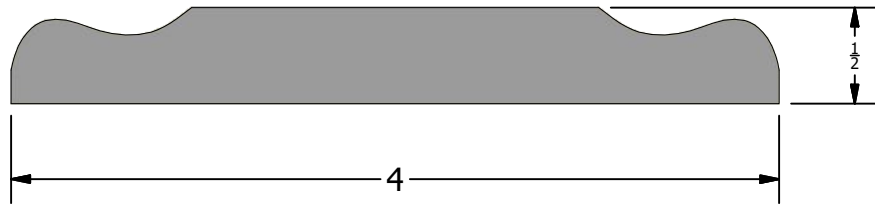

Description
Casing Base Board

Part Number
CB-69

-196-

Back

Scale 1 : 1



HOMESTEAD
WOODWORKS

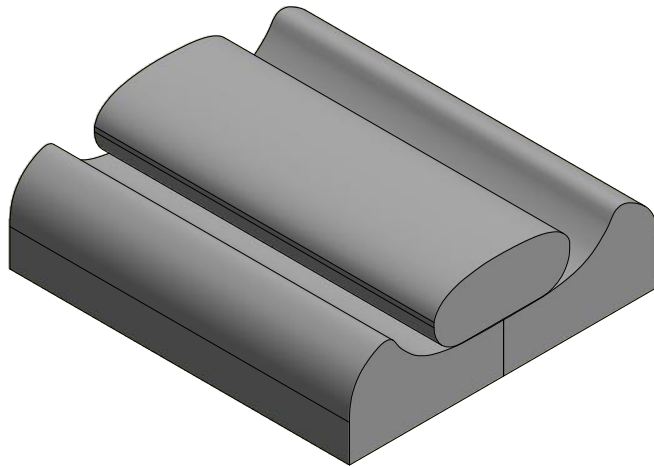
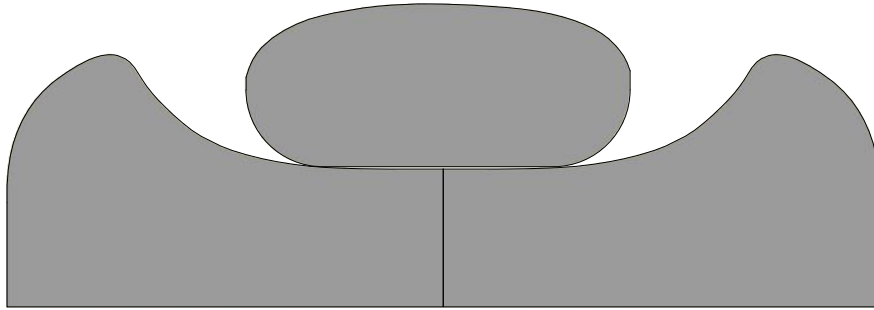

Description
Casing Base Board

Part Number
CB-70

-197-

Back

Scale 1



HOMESTEAD
WOODWORKS

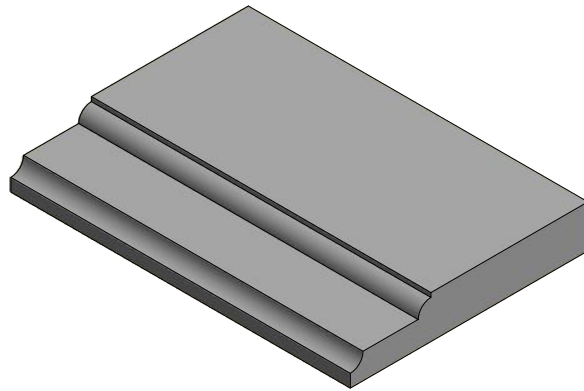
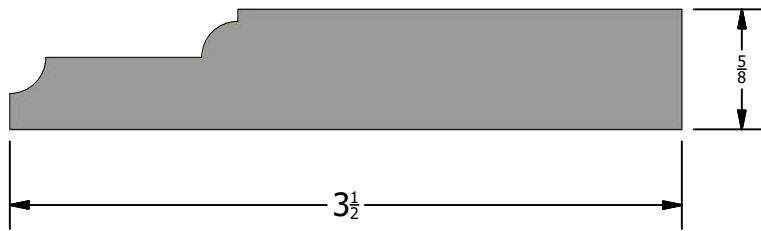

Description
Casing Base Board

Part Number
CB-71

-198-

Back

Scale 1 : 1



HOMESTEAD
WOODWORKS

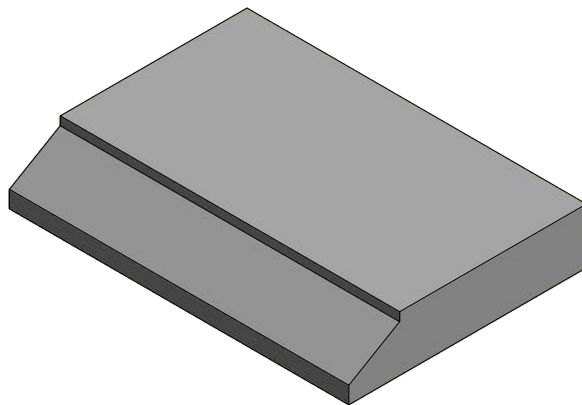
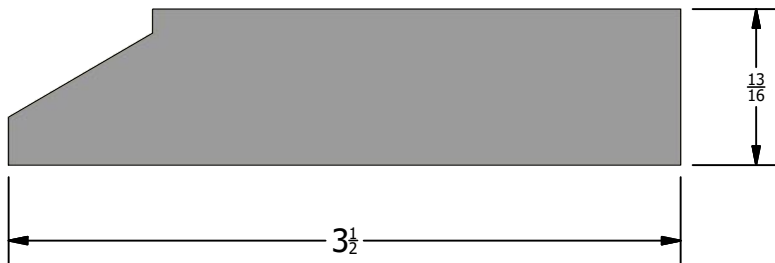

Description
Casing Base Board

Part Number
CB-72-A

-199-

Back

Scale 1 : 1



HOMESTEAD
WOODWORKS

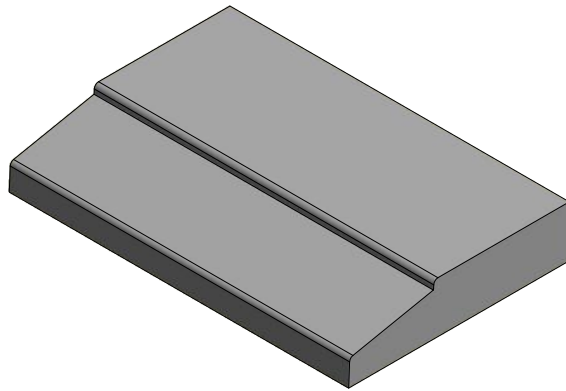
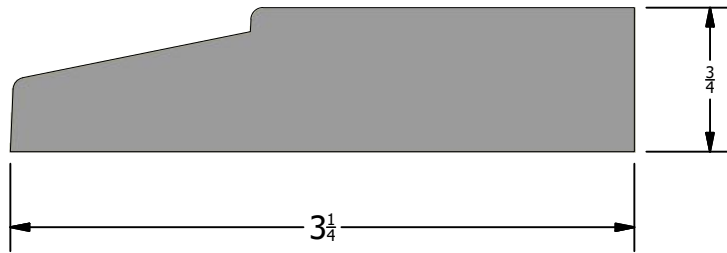

Description
Casing Base Board

Part Number
CB-72-B

-200-

Back

Scale 1 : 1



HOMESTEAD
WOODWORKS

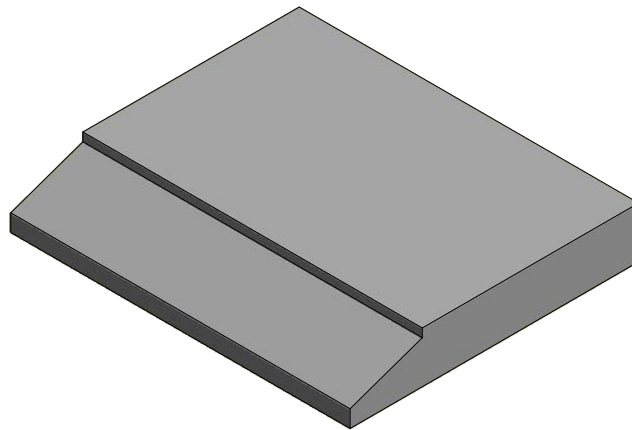
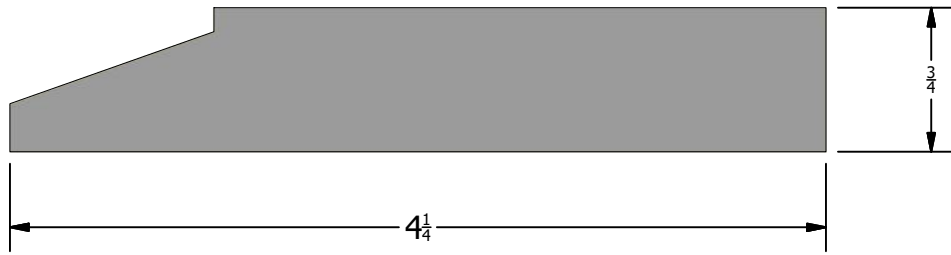

Description
Casing Base Board

Part Number
CB-72-C

-201-

Back

Scale 1 : 1



HOMESTEAD
WOODWORKS

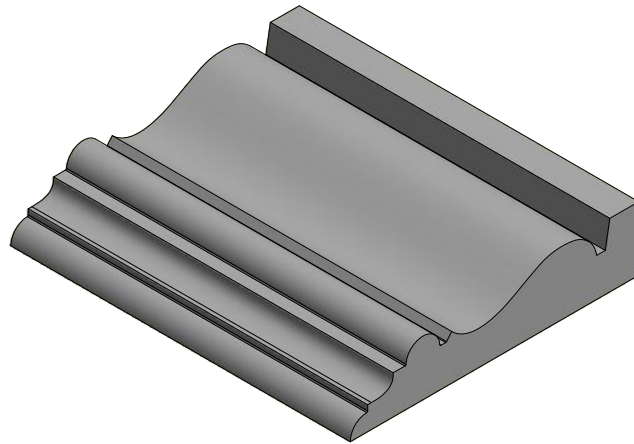
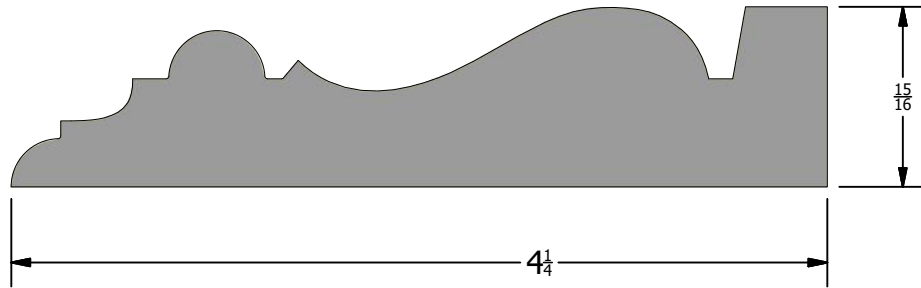

Description
Casing Base Board

Part Number
CB-73

-202-

Back

Scale 1 : 1



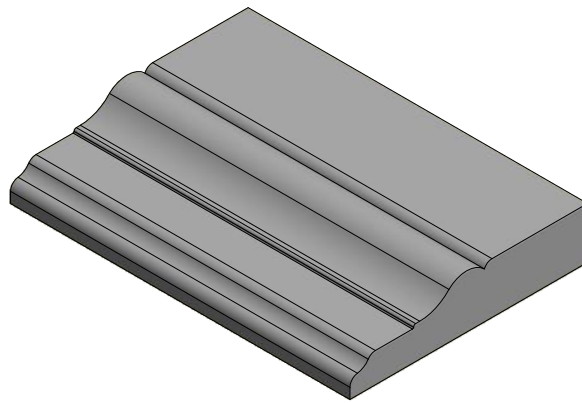
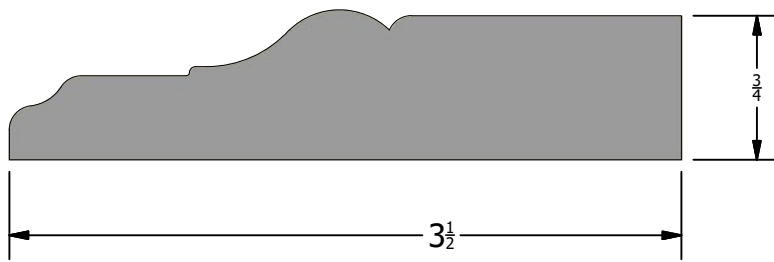

Description
Casing Base Board

Part Number
CB-74

-203-

Back

Scale 1 : 1



HOMESTEAD
WOODWORKS

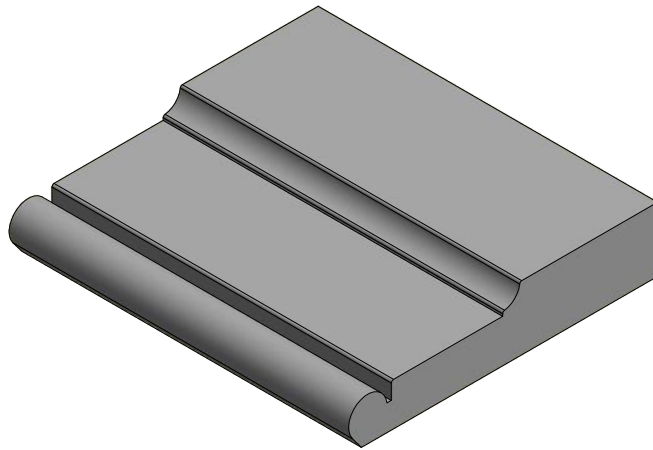

Description
Casing Base Board

Part Number
CB-75

-204-

Back

Scale 1 : 1



HOMESTEAD
WOODWORKS

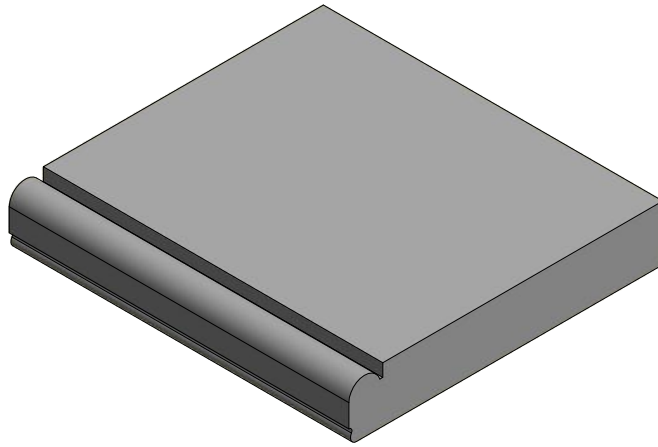
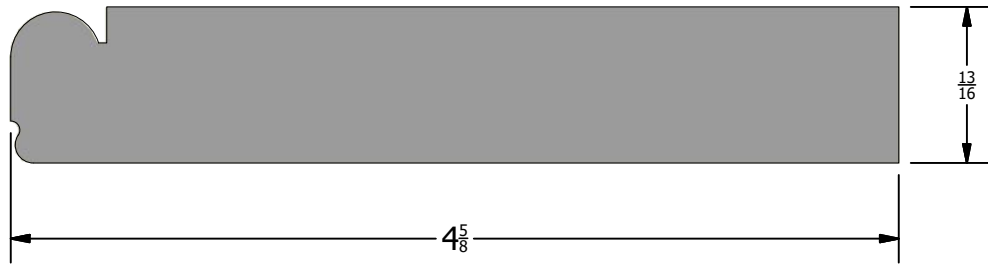

Description
Casing Base Board

Part Number
CB-76

-205-

Back

Scale 1 : 1



HOMESTEAD
WOODWORKS

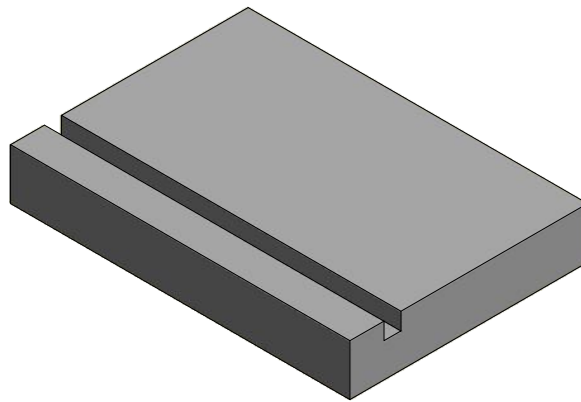
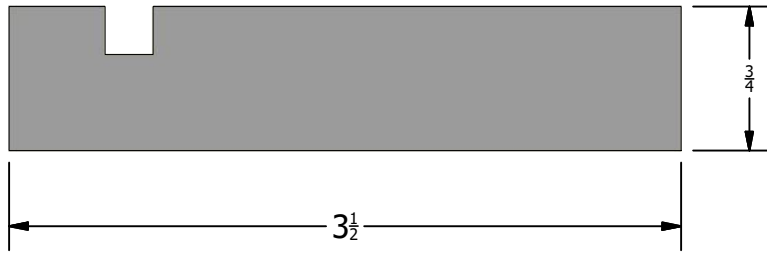

Description
Casing Base Board

Part Number
CB-77



-206-

Back

Scale 1 : 1

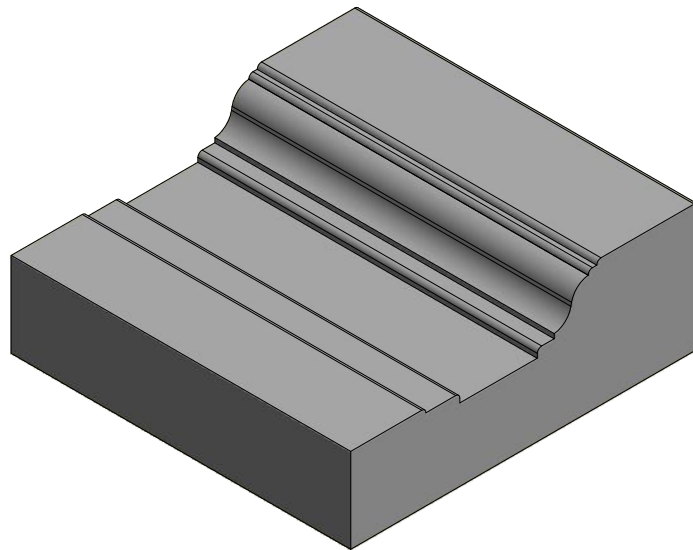

Description
Casing Base Board

Part Number
CB-78

-207-

Back

Scale 1 : 1



HOMESTEAD
WOODWORKS

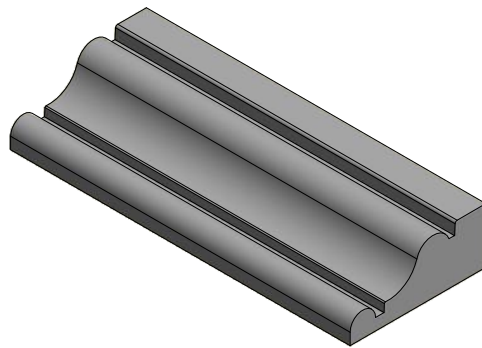
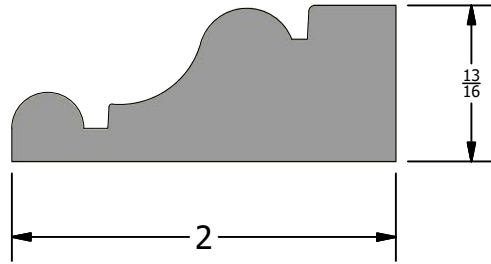

Description
Casing Base Board

Part Number
CB-79

-208-

Back

Scale 1 : 1



HOMESTEAD
WOODWORKS

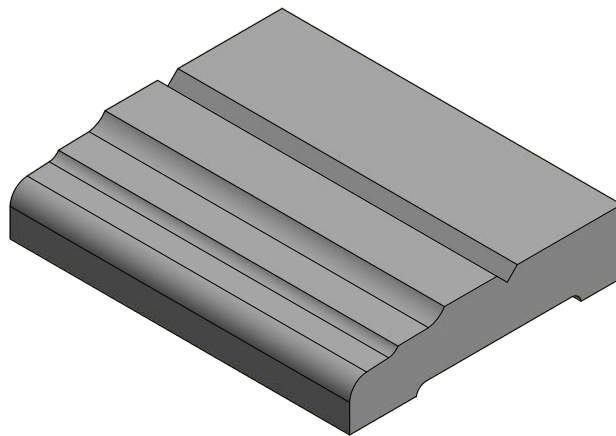
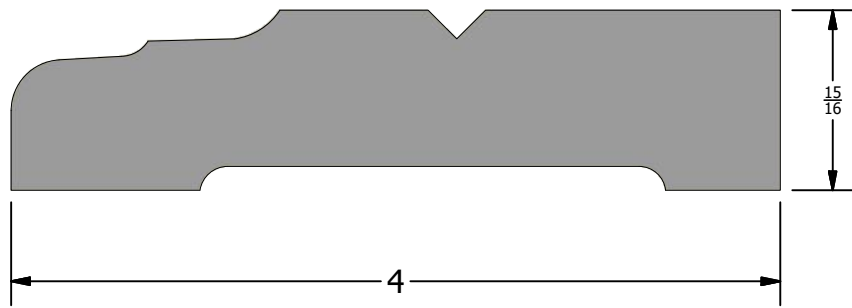

Description
Casing Base Board

Part Number
CB-80



-209-

Back

Scale 1 : 1

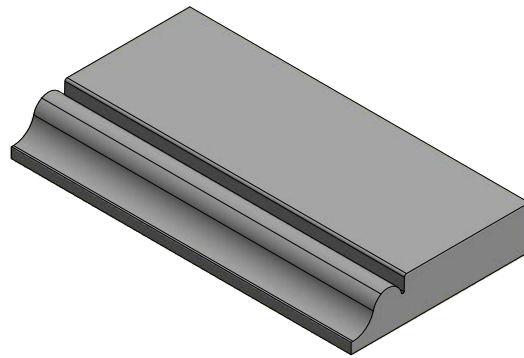
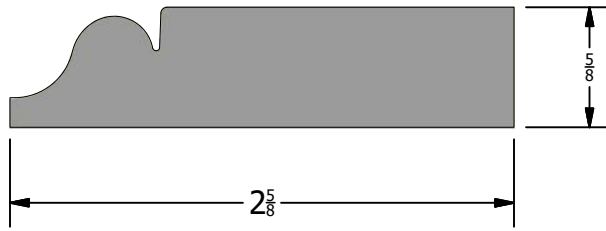

Description
Casing Base Board

Part Number
CB-81

-210-

Back

Scale 1



HOMESTEAD
WOODWORKS

Description

Part Number

-210-

Back

Scale



HOMESTEAD
WOODWORKS

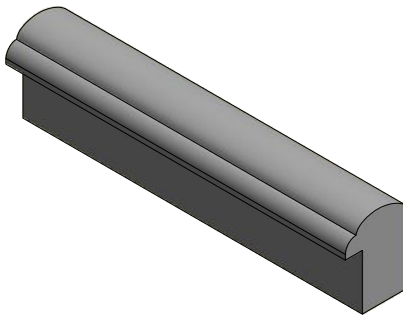
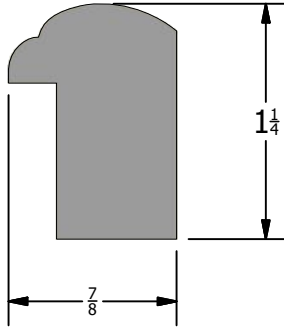

Description
Back Band

Part Number
BB-01

-211-

Back

Scale 1 : 1



HOMESTEAD
WOODWORKS

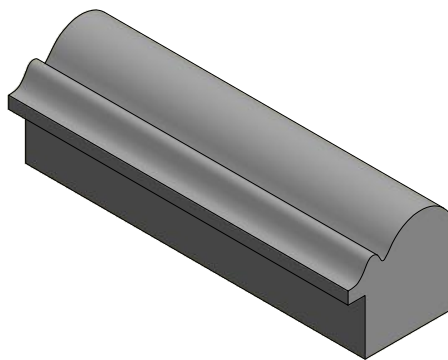
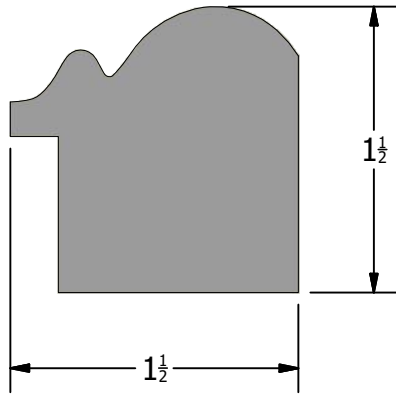

Description
Back Band

Part Number
BB-02

-212-

Back

Scale 1 : 1



HOMESTEAD
WOODWORKS

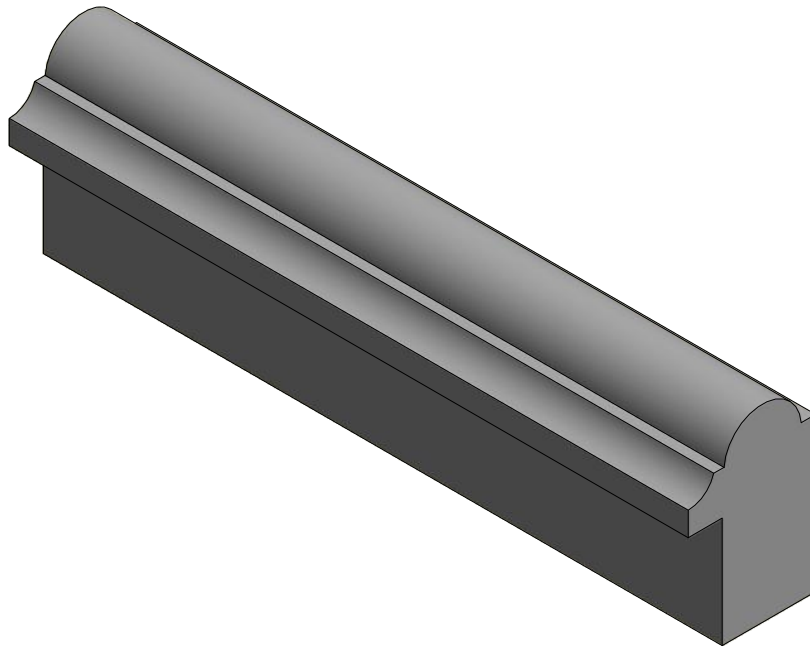
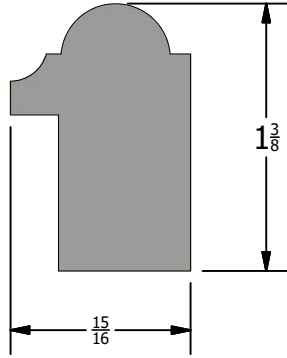

Description
Back Band

Part Number
BB-03-A

-213-

Back

Scale 1 : 1



HOMESTEAD
WOODWORKS

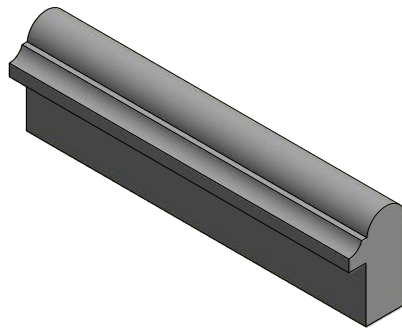
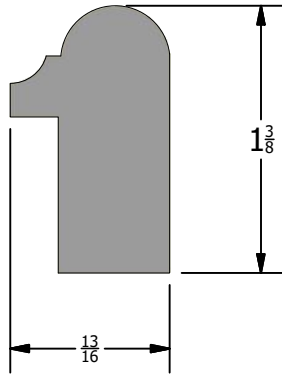

Description
Back Band

Part Number
BB-03-B



-214-

Back

Scale 1 : 1

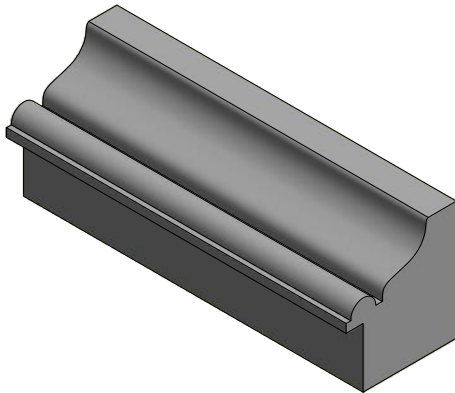
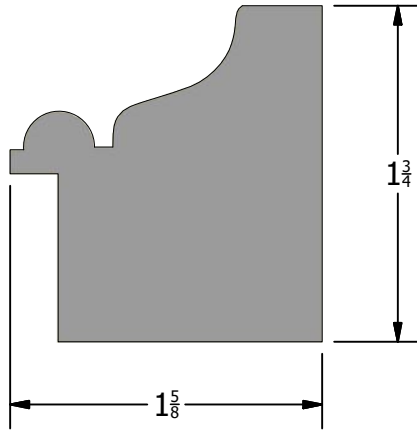

Description Back Band		Part Number BB-04	 HOMESTEAD WOODWORKS
-215-	Back	Scale 1 : 1	

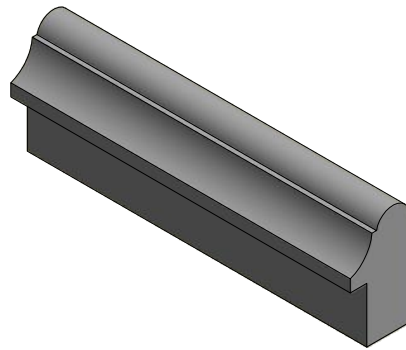
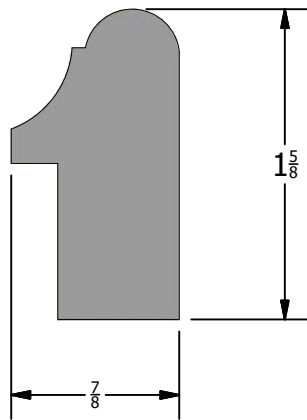

Description Back Band		Part Number BB-05	 HOMESTEAD WOODWORKS
-216-	Back	Scale 1 : 1	

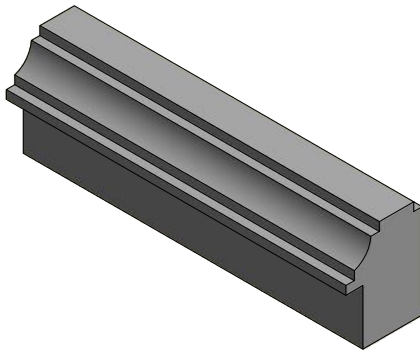
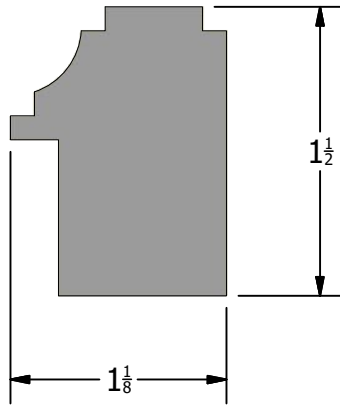

Description
Back Band

Part Number
BB-06

-217-

Back

Scale 1 : 1



HOMESTEAD
WOODWORKS

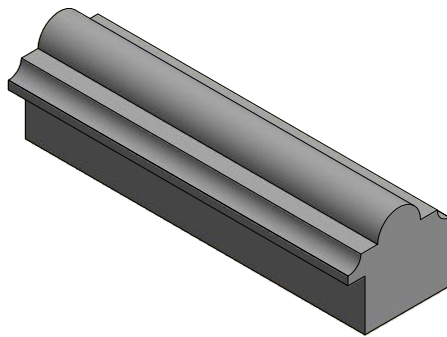
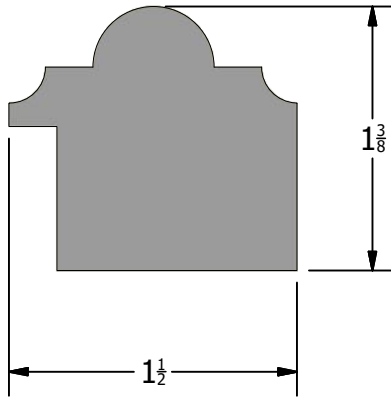

Description
Back Band

Part Number
BB-07

-218-

Back

Scale 1 : 1



HOMESTEAD
WOODWORKS

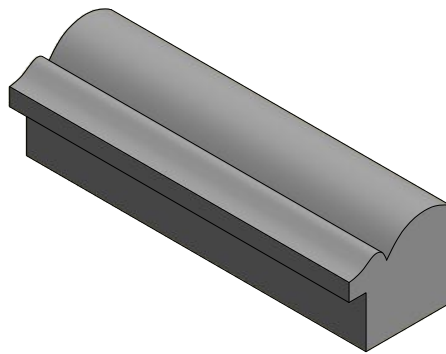
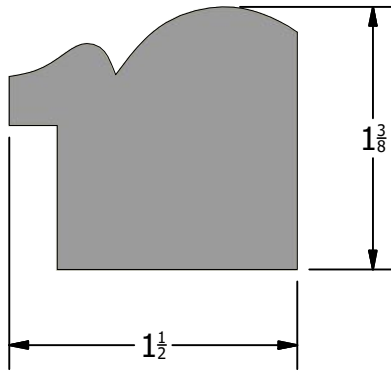

Description
Back Band

Part Number
BB-08



-219-

Back

Scale 1 : 1

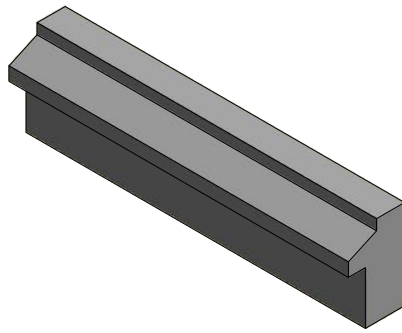
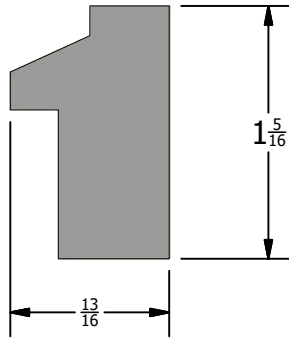

Description
Back Band

Part Number
BB-09

-220-

Back

Scale 1 : 1



HOMESTEAD
WOODWORKS

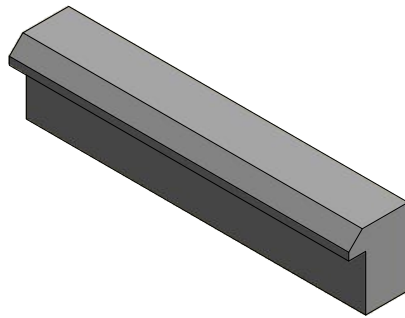
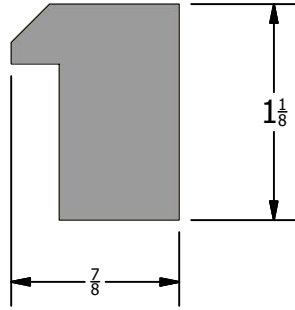

Description
Back Band

Part Number
BB-10

-221-

Back

Scale 1 : 1



HOMESTEAD
WOODWORKS

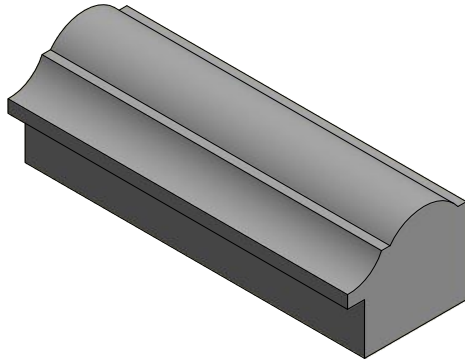
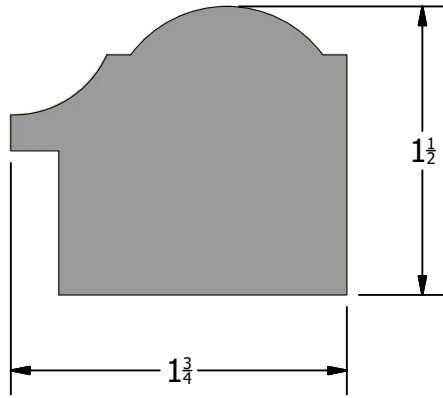

Description
Back Band

Part Number
BB-11-A

-222-

Back

Scale 1 : 1



HOMESTEAD
WOODWORKS

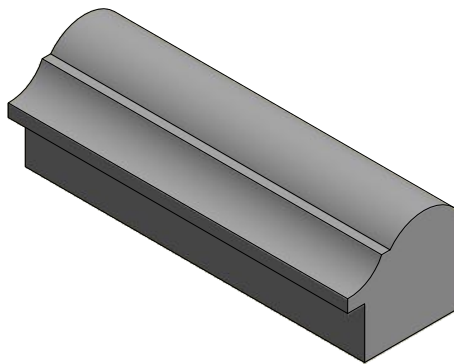
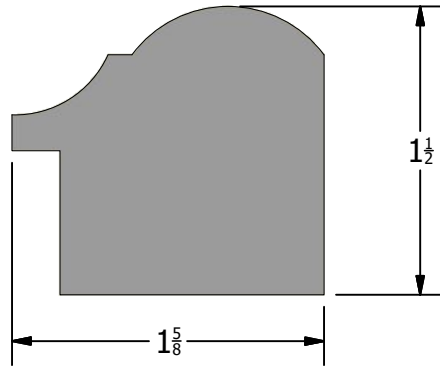

Description Back Band		Part Number BB-11-B	 HOMESTEAD WOODWORKS
-223-	Back	Scale 1 : 1	

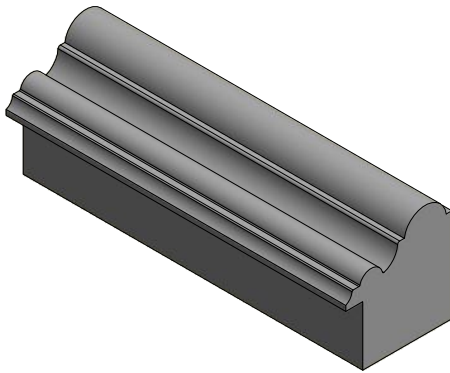
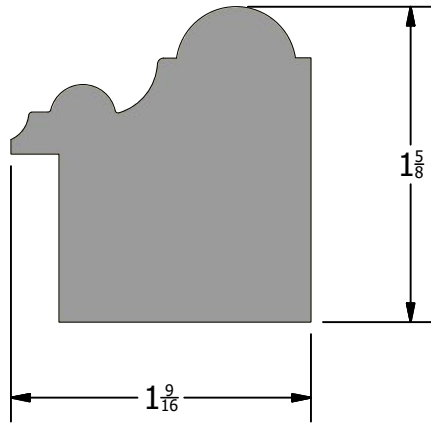

Description
Back Band

Part Number
BB-12

-224-

Back

Scale 1 : 1



HOMESTEAD
WOODWORKS

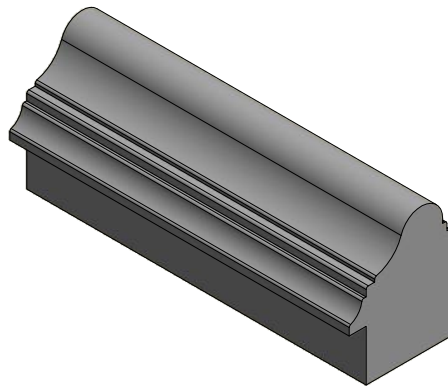
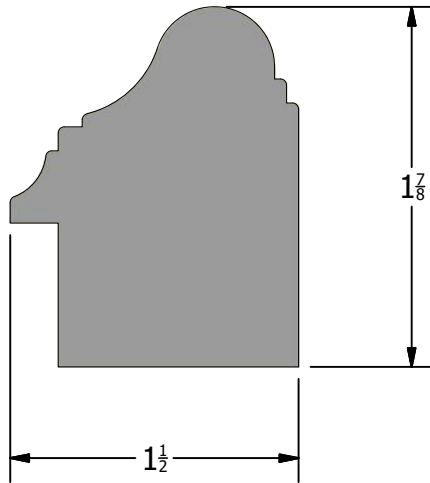

Description
Back Band

Part Number
BB-13

-225-

Back

Scale 1 : 1

HOMESTEAD
WOODWORKS

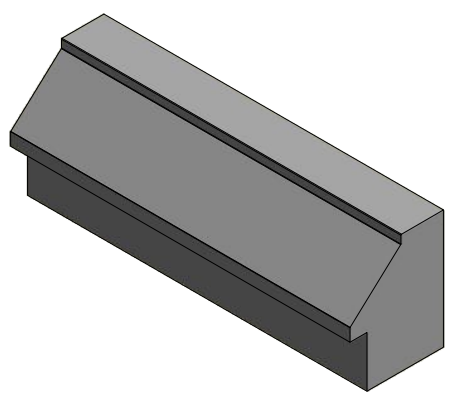
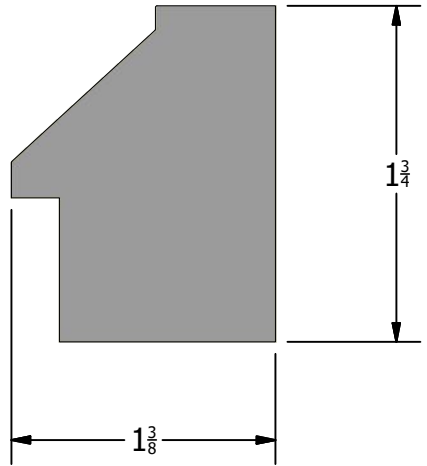

Description
Back Band

Part Number
BB-14



-226-

Back

Scale 1 : 1

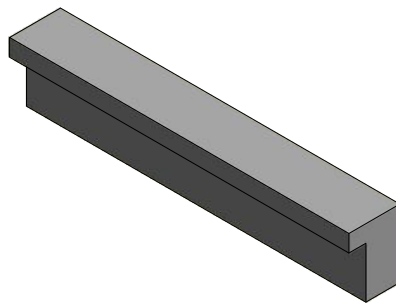
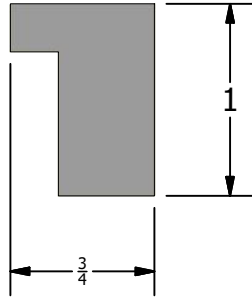

Description
Back Band

Part Number
BB-15

-227-

Back

Scale 1 : 1



HOMESTEAD
WOODWORKS

Description

Part Number

-228-

Back

Scale



HOMESTEAD
WOODWORKS

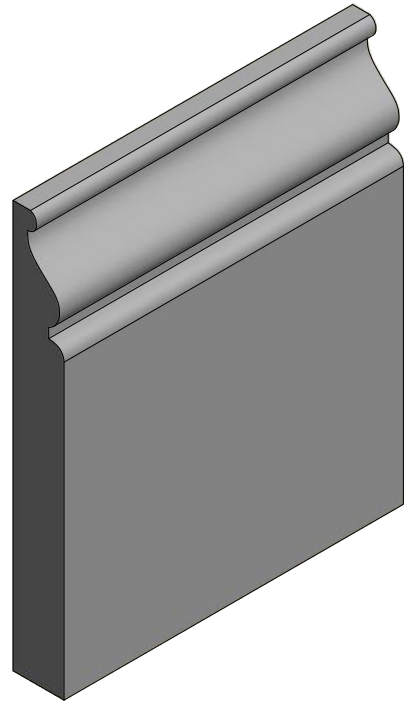
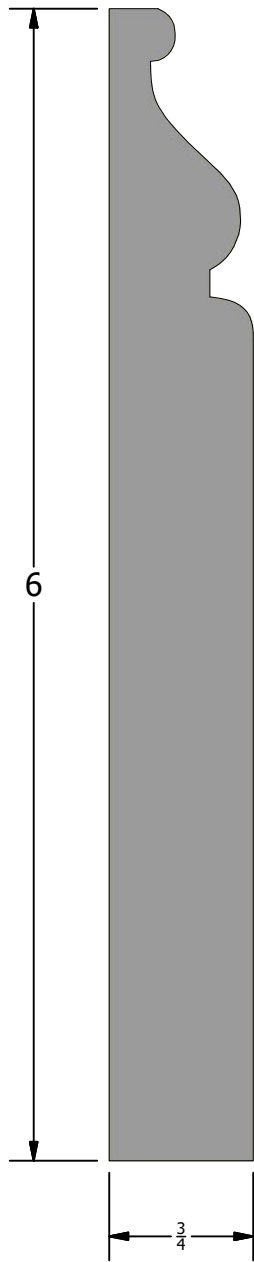

Description
Base Board

Part Number
Base-01

-229-

Back

Scale 1 : 1

HOMESTEAD
WOODWORKS

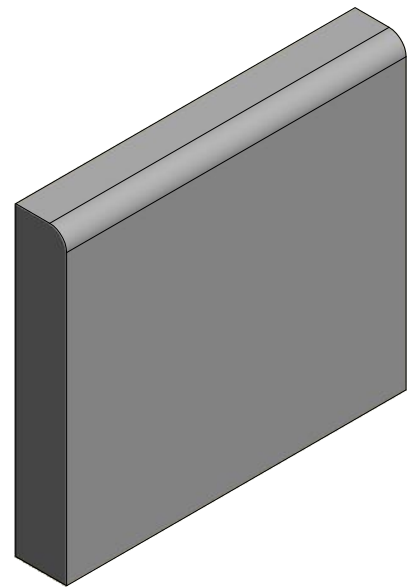
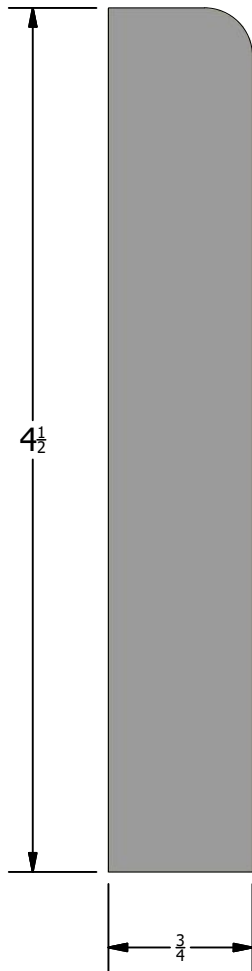

Description
Base Board

Part Number
Base-02

-230-

Back

Scale 1 : 1



HOMESTEAD
WOODWORKS

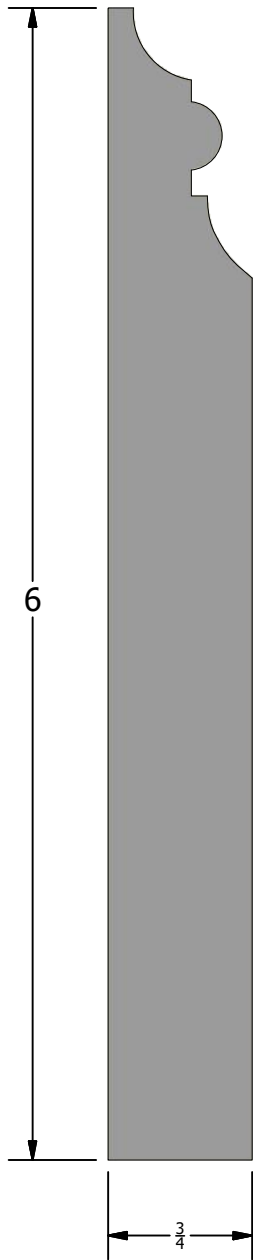

Description
Base Board

Part Number
Base-03

-231-

Back

Scale 1 : 1



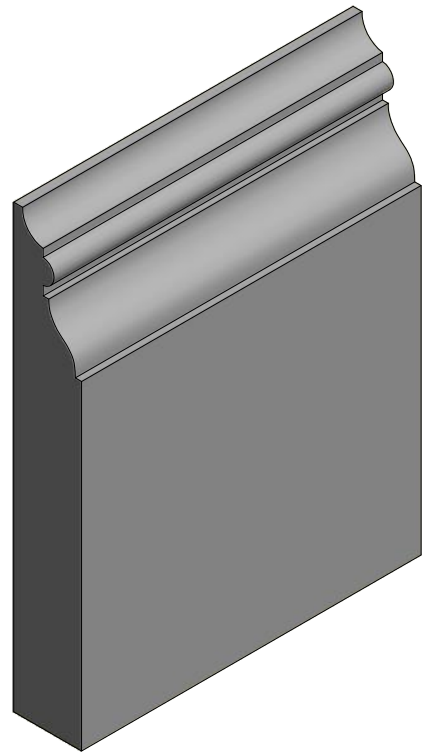
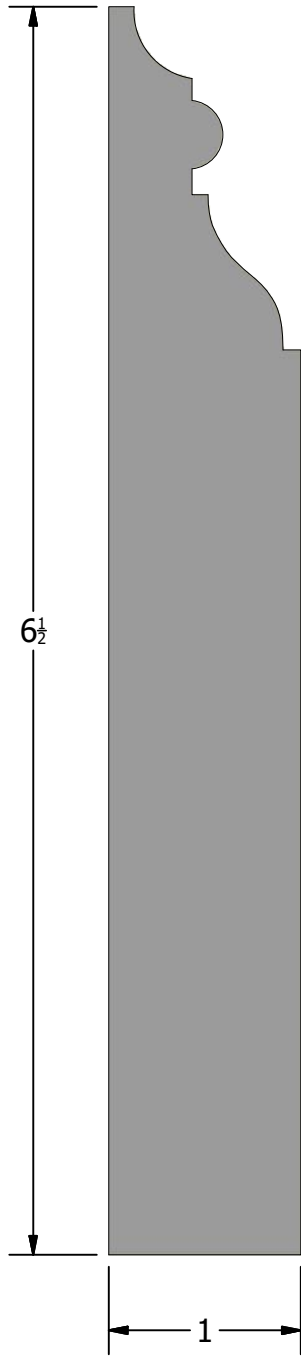

Description
Base Board

Part Number
Base-04

-232-

Back

Scale 1 : 1

HOMESTEAD
WOODWORKS

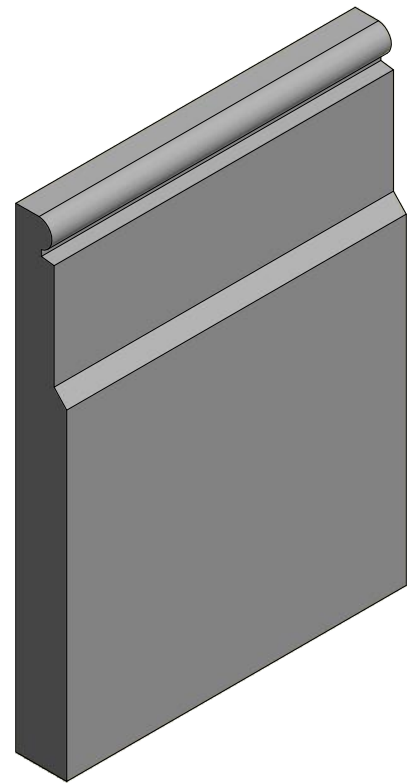
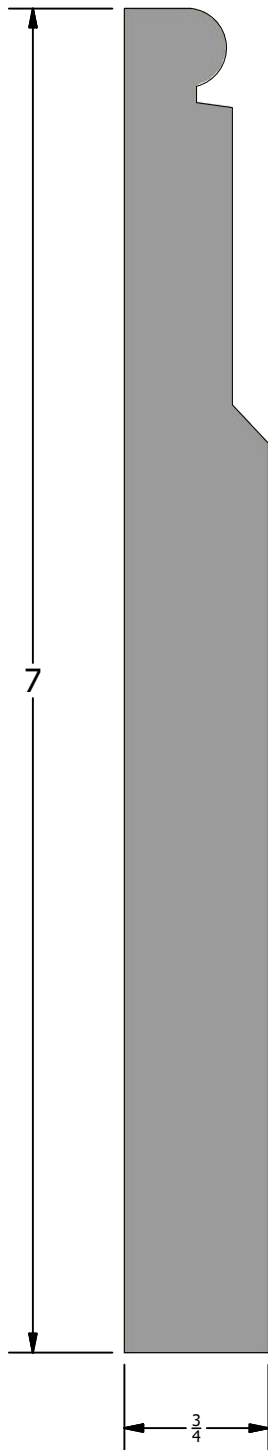

Description
Base Board

Part Number
Base-05

-233-

Back

Scale 1 : 1



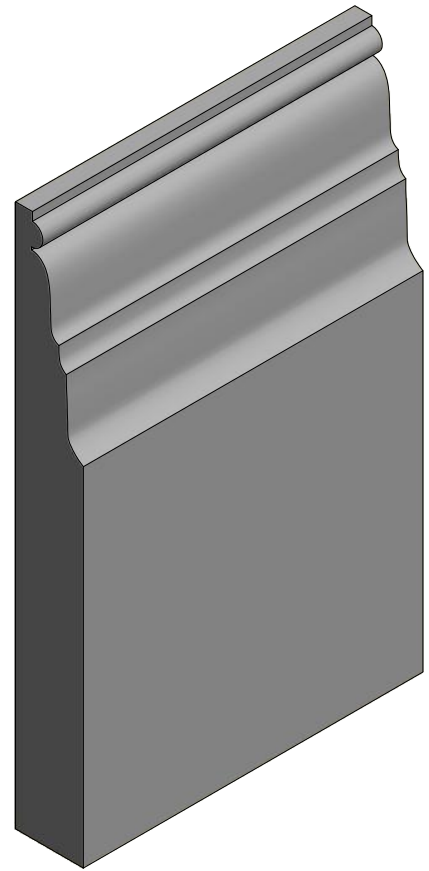
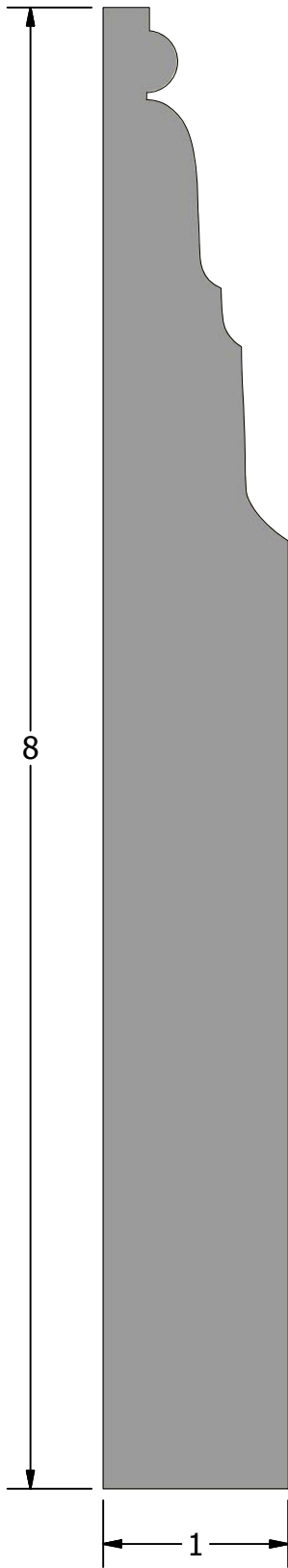

Description
Base Board

Part Number
Base-06

-234-

Back

Scale 1 : 1

HOMESTEAD
WOODWORKS

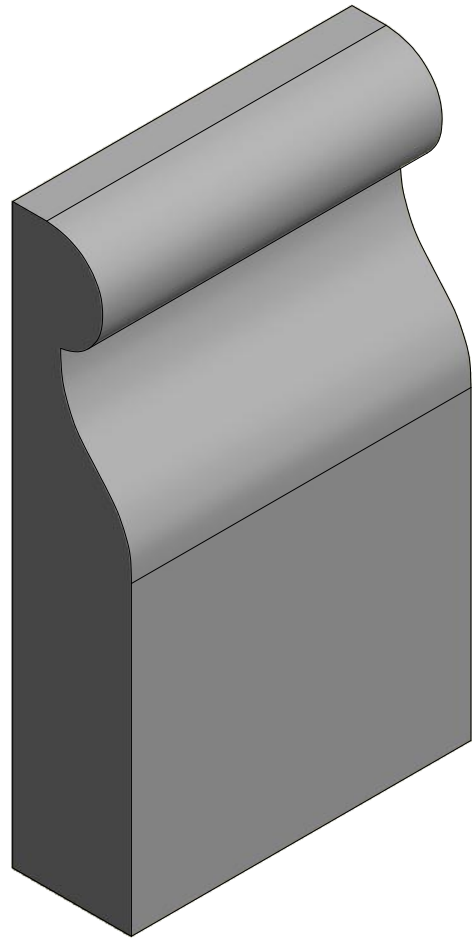
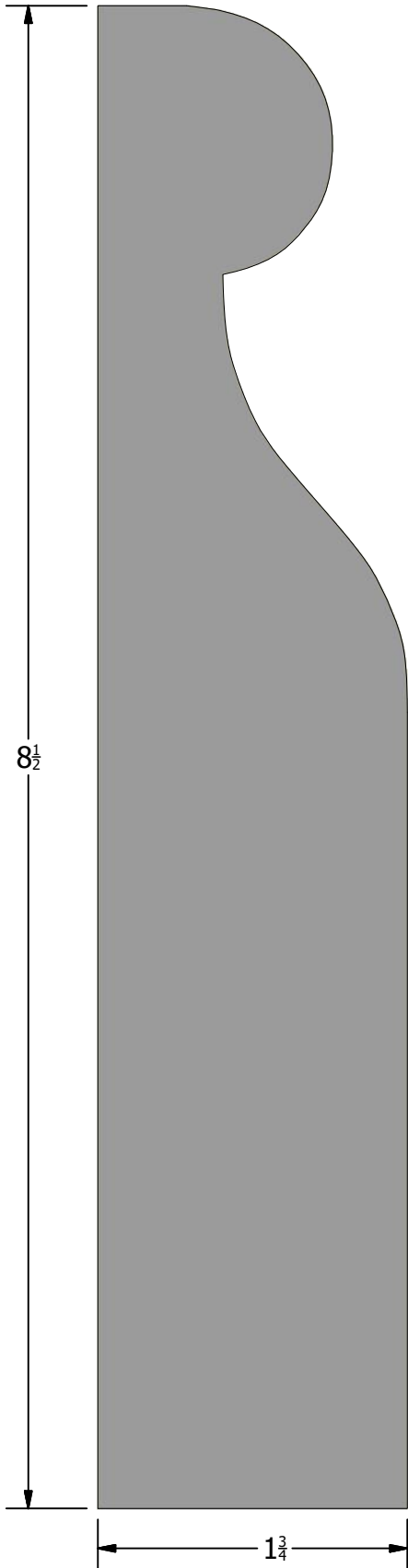

Description
Base Board

Part Number
Base-07

-235-

Back

Scale 1 : 1



HOMESTEAD
WOODWORKS

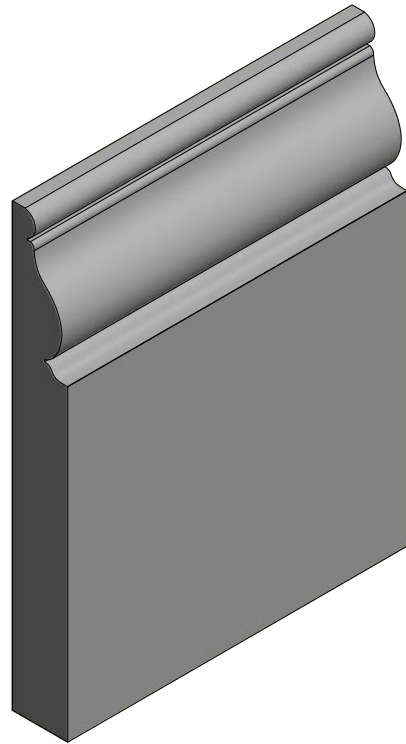
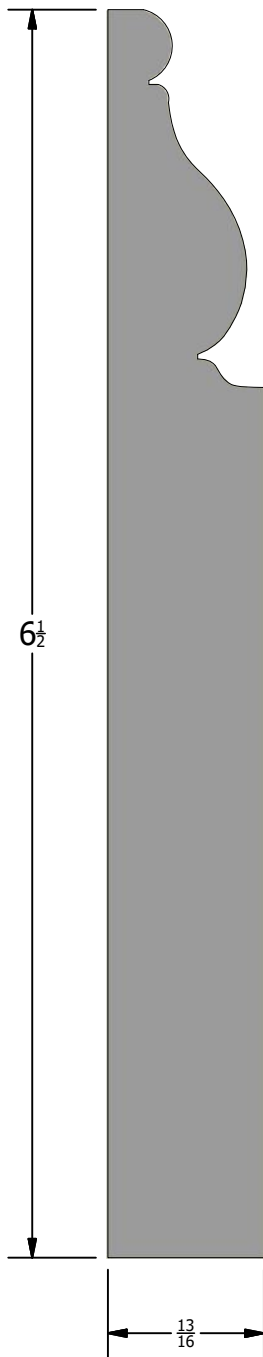

Description
Base Board

Part Number
Base-08

-236-

Back

Scale 1 : 1



HOMESTEAD
WOODWORKS

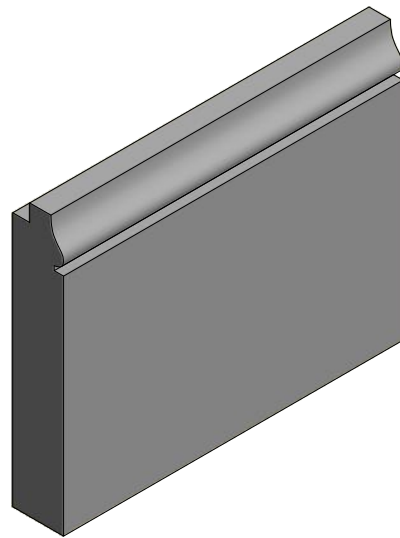
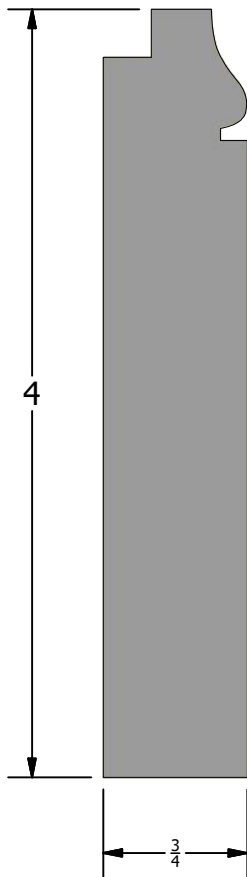

Description
Base Board

Part Number
Base-09

-237-

Back

Scale 1 : 1



HOMESTEAD
WOODWORKS

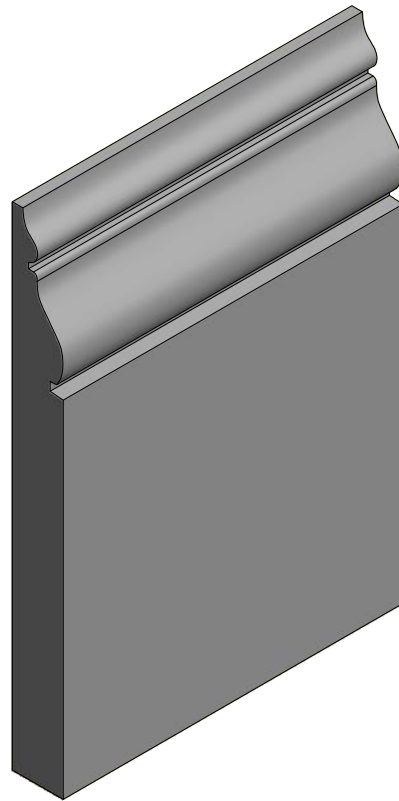
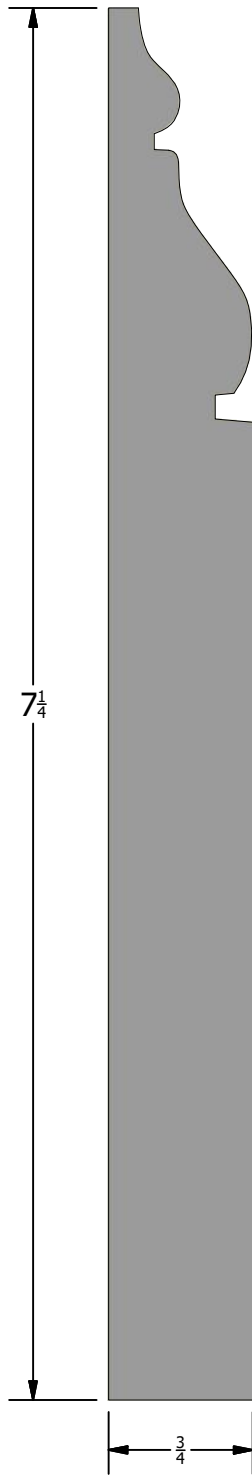

Description
Base Board

Part Number
Base-10

-238-

Back

Scale 1 : 1

HOMESTEAD
WOODWORKS

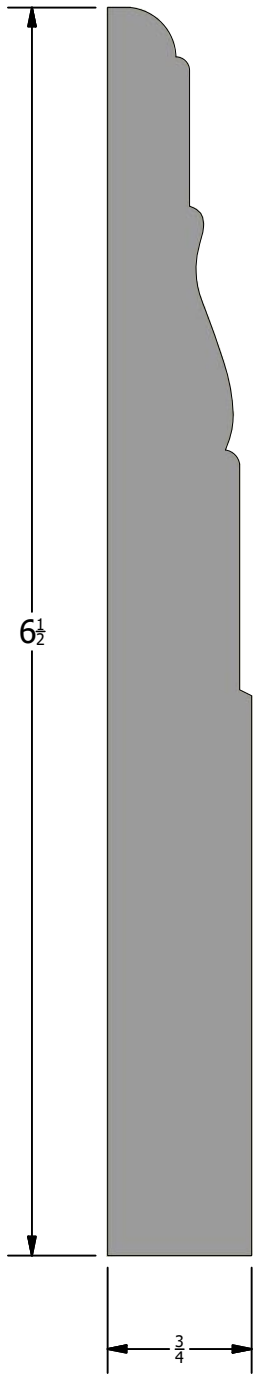

Description
Base Board

Part Number
Base-11

-239-

Back

Scale 1 : 1

HOMESTEAD
WOODWORKS

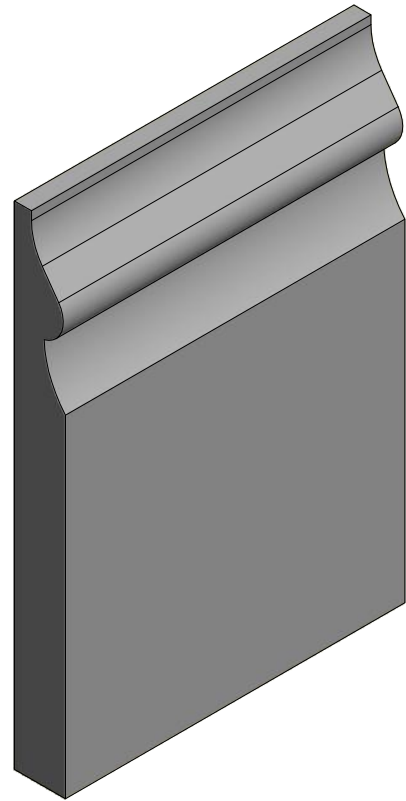
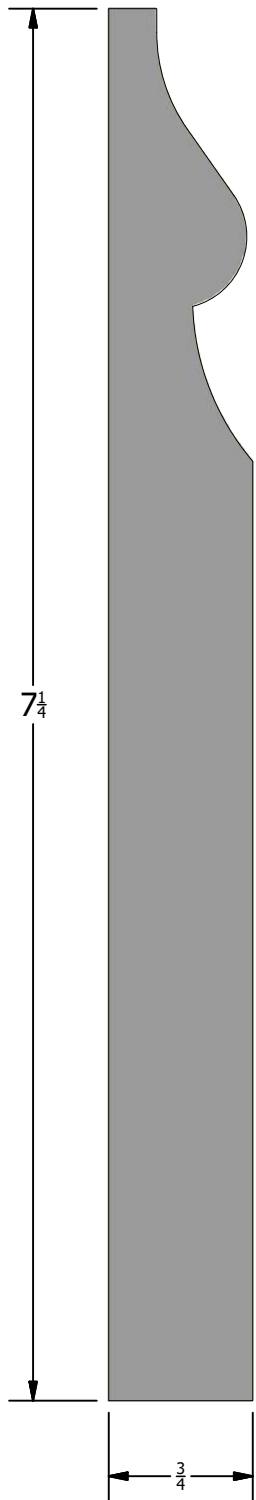

Description
Base Board

Part Number
Base-12

-240-

Back

Scale 1 : 1

HOMESTEAD
WOODWORKS

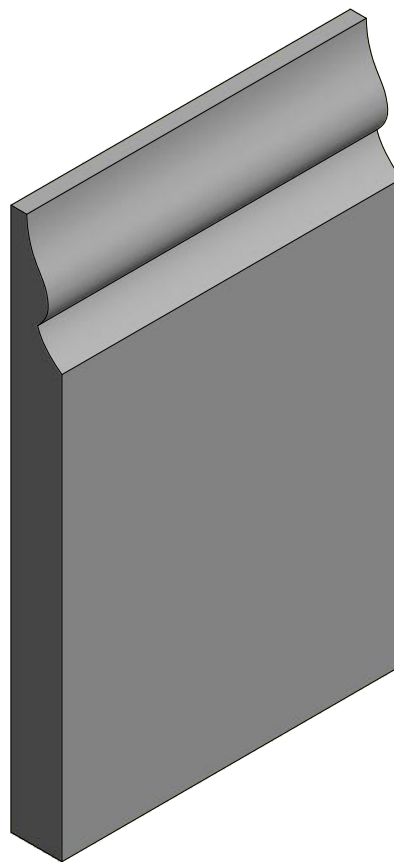
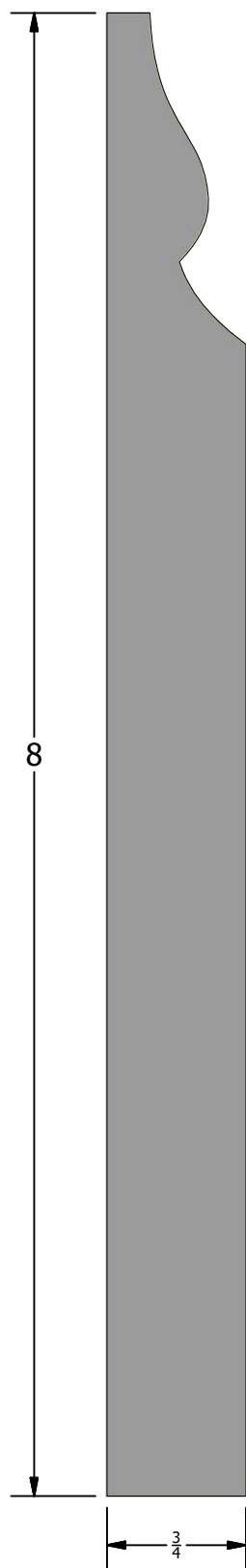

Description
Base Board

Part Number
Base-13

-241-

Back

Scale 1 : 1



HOMESTEAD
WOODWORKS

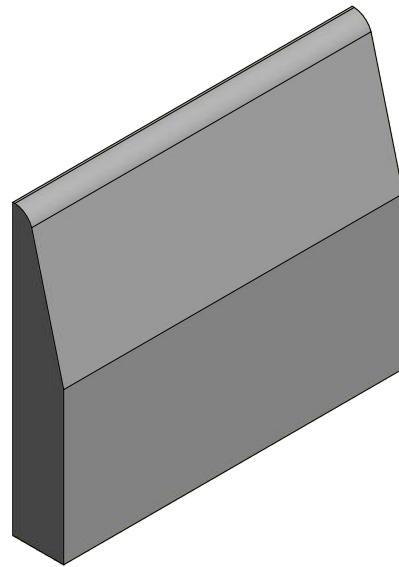
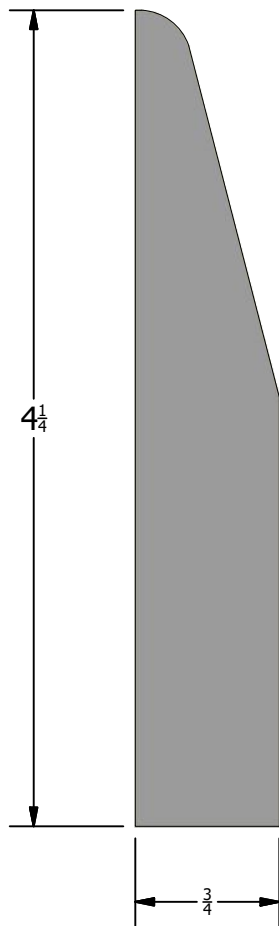

Description
Base Board

Part Number
Base-14

-242-

Back

Scale 1 : 1



HOMESTEAD
WOODWORKS

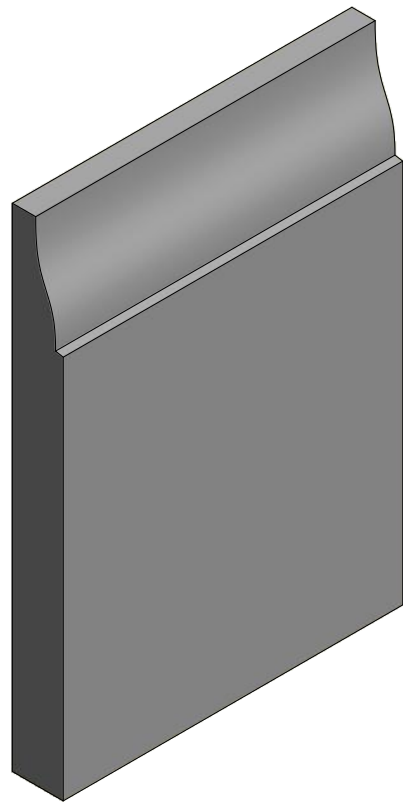
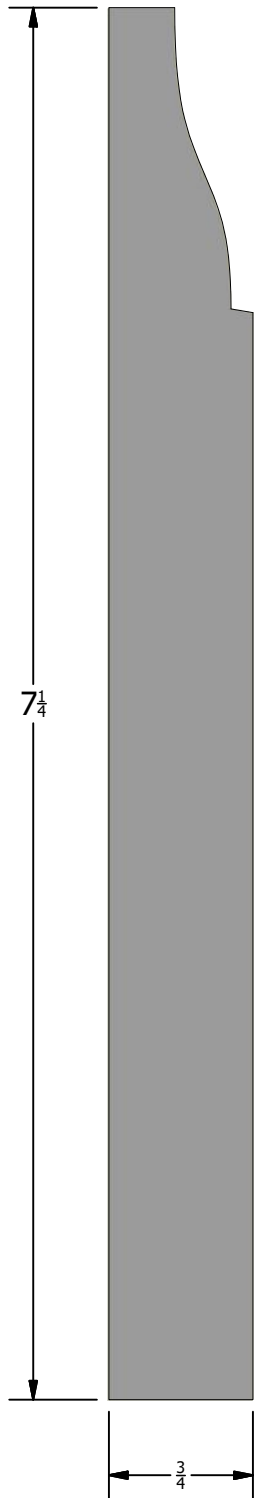

Description
Base Board

Part Number
Base-15

-243-

Back

Scale 1 : 1



HOMESTEAD
WOODWORKS

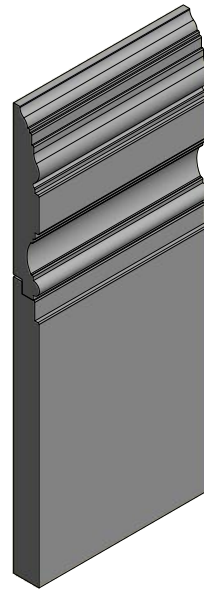
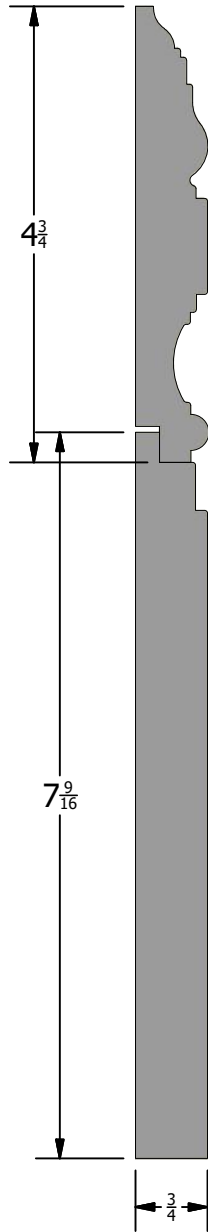

Description
Base Board

Part Number
Base-16

-244-

Back

Scale 1 / 2



HOMESTEAD
WOODWORKS

Description

Part Number

-245-

Back

Scale



HOMESTEAD
WOODWORKS

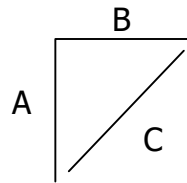
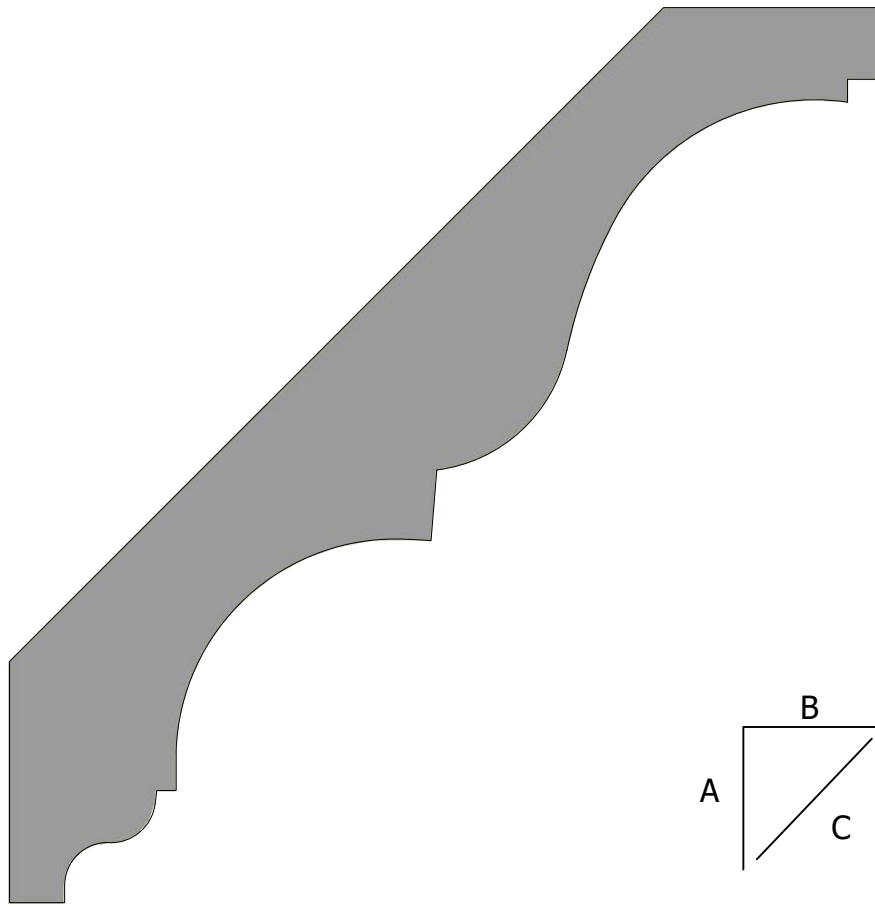

A: 4 1/2"
 B: 4 1/2"
 C: 6 3/8"

6/4

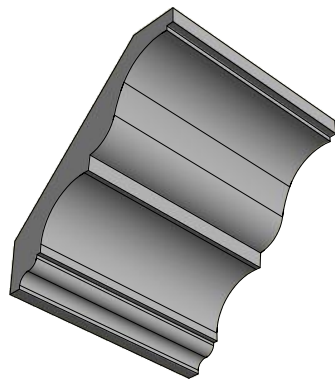

Description
 Crown Mould

Part Number
 CRO-01

-246-

Back

Scale 1



HOMESTEAD
 WOODWORKS

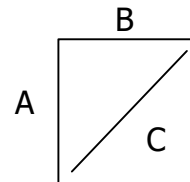
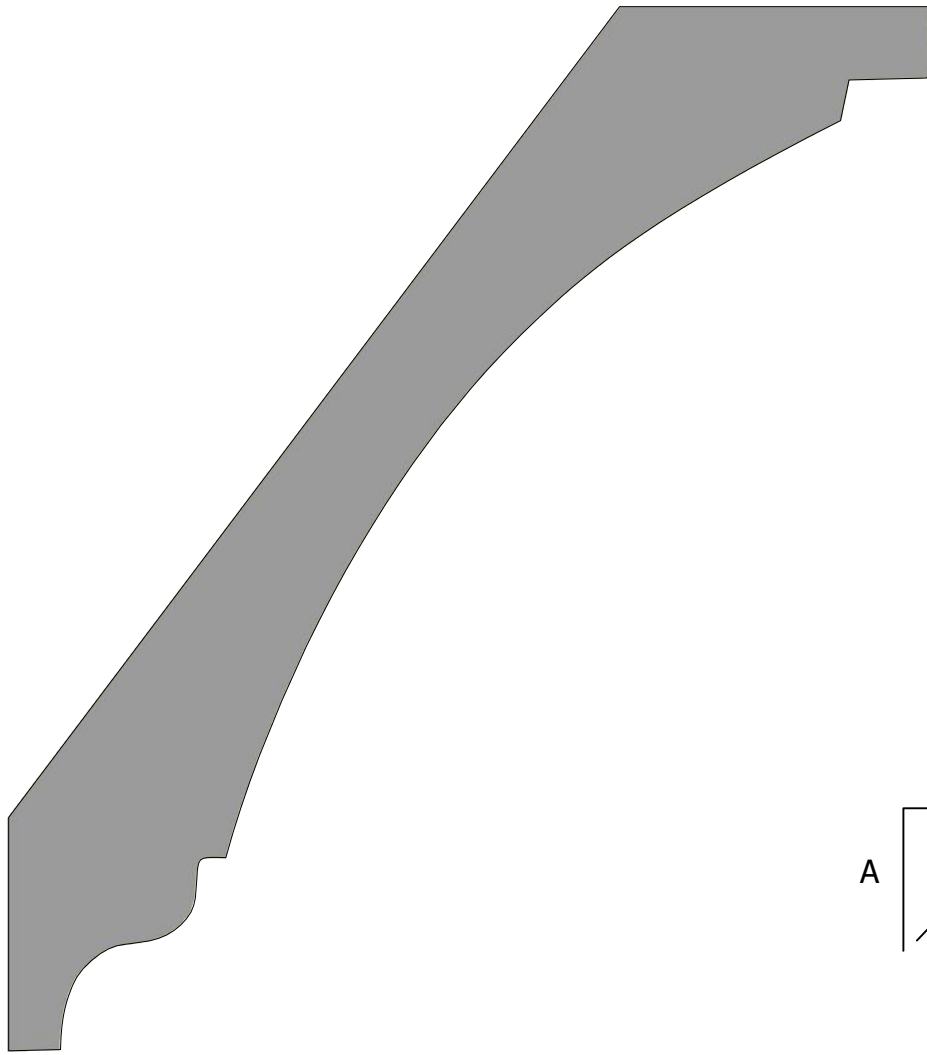

A: 5 7/16"
B: 4 13/16"
C: 7 1/4"
6/4



Description
Crown Mould

Part Number
CRO-02

-247-

Back

Scale 1 : 1



HOMESTEAD
WOODWORKS

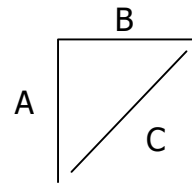
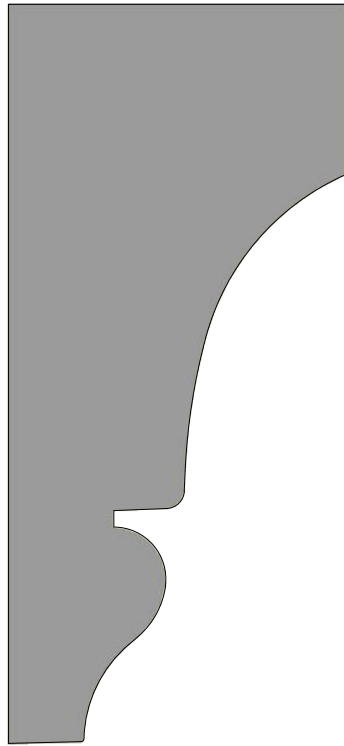

A: 3 5/8"
B: 1 3/4"
C: 4 1/8"

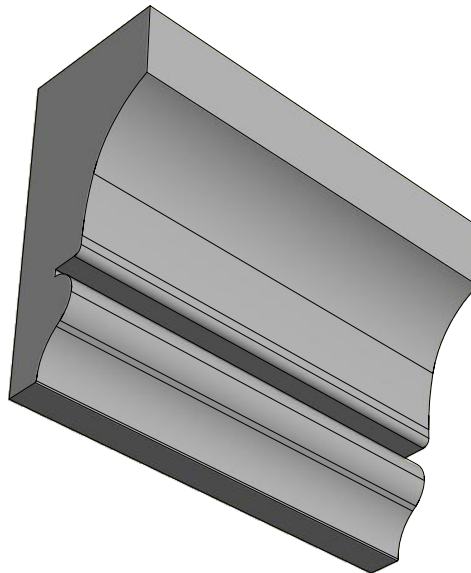

Description
Crown Mould

Part Number
CRO-03

-248-

Back

Scale 1 : 1



HOMESTEAD
WOODWORKS

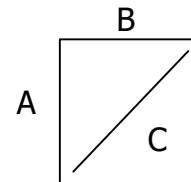
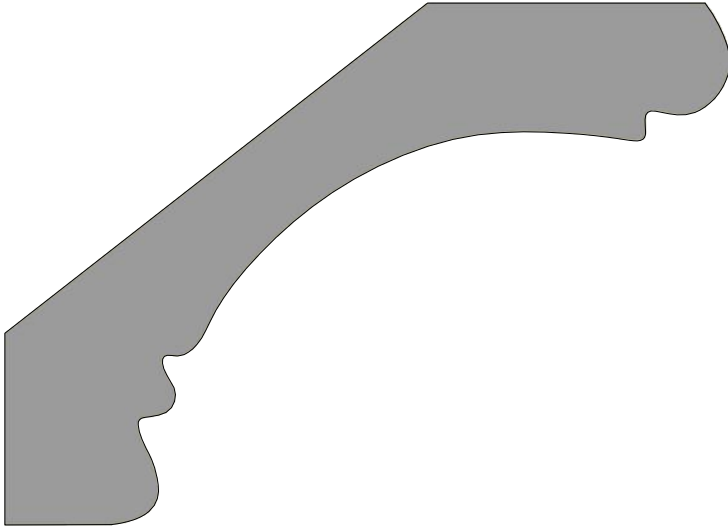

A: 2 11/16"
B: 3 5/8"
C: 4 9/16"

6/4

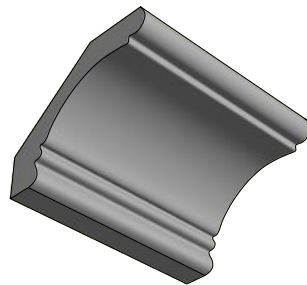

Description
Crown Mould

Part Number
CRO-04

-249-

Back

Scale 1 : 1



HOMESTEAD
WOODWORKS

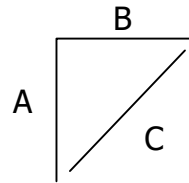
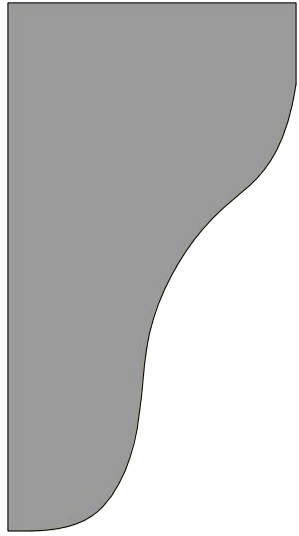

A: 2 3/4"
B: 1 1/2"
C: 3 1/8"

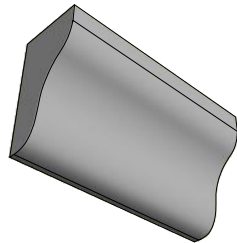

Description
Crown Mould

Part Number
CRO-05

-250-

Back

Scale 1 : 1



HOMESTEAD
WOODWORKS

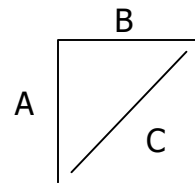
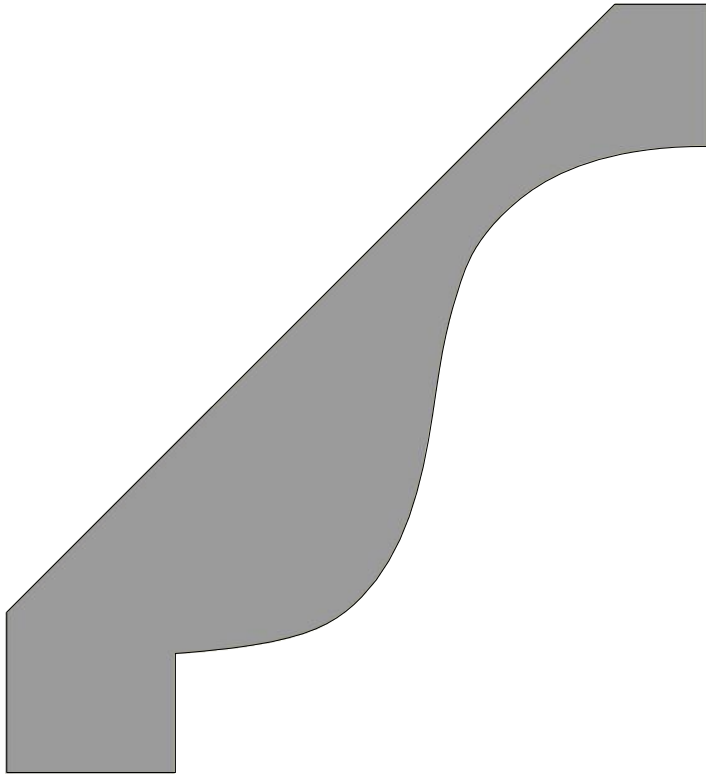

A: 4"
B: 3 5/8"
C: 5 7/16"

6/4

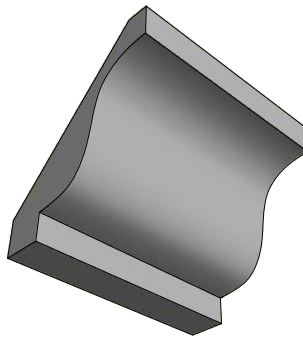

Description
Crown Mould

Part Number
CRO-06

-251-

Back

Scale 1 : 1



HOMESTEAD
WOODWORKS

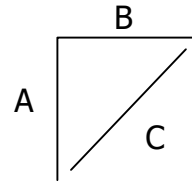
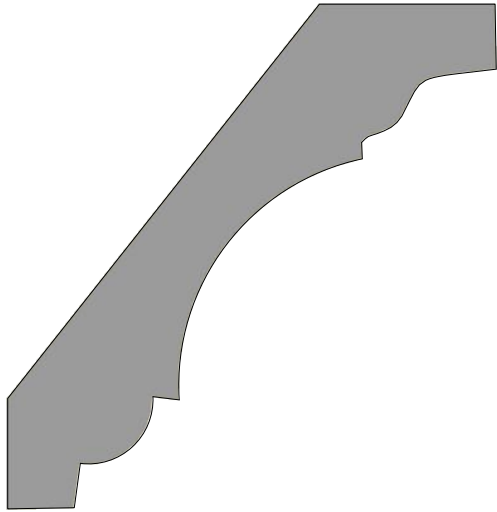

A: 2 5/8"
 B: 2 9/16"
 C: 3 5/8"

4/4

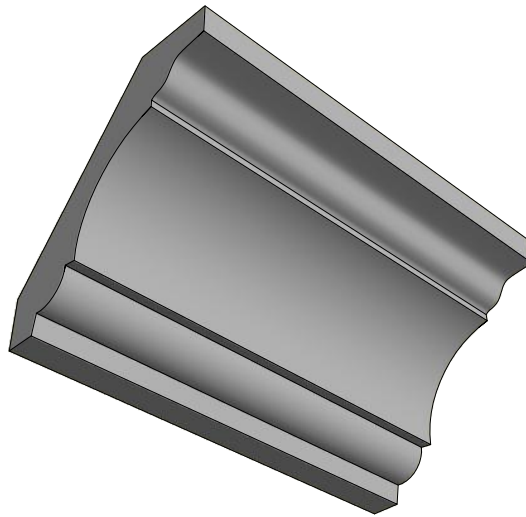

Description
 Crown Mould

Part Number
 CRO-07

-252-

Back

Scale 1 : 1



HOMESTEAD
 WOODWORKS

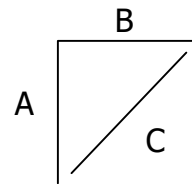
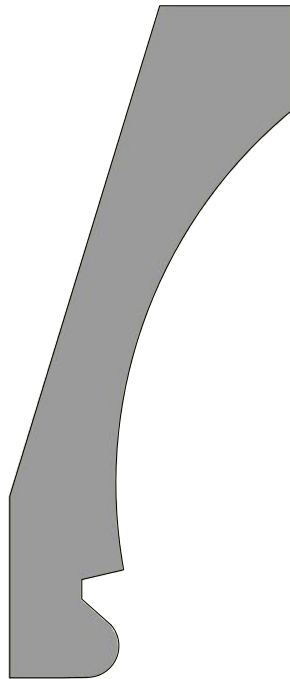

A: 3 1/2"
B: 1 7/16"
C: 3 13/16"

4/4

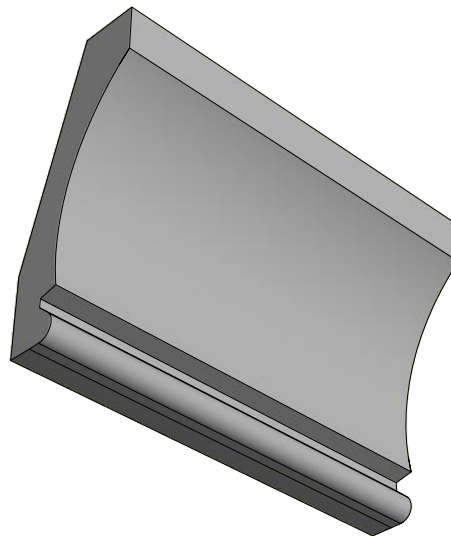

Description
Crown Mould

Part Number
CRO-08

-253-

Back

Scale 1 : 1



HOMESTEAD
WOODWORKS

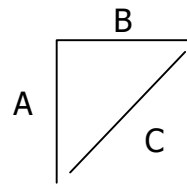
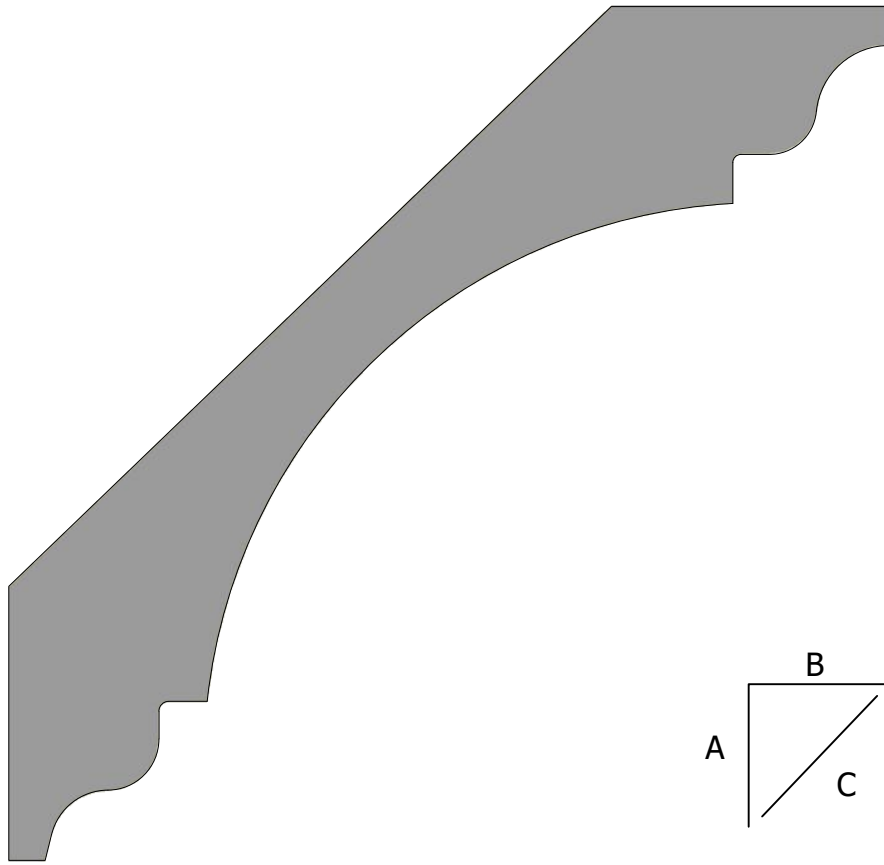

A: 4 7/16"
 B: 4 9/16"
 C: 6 3/8"

6/4

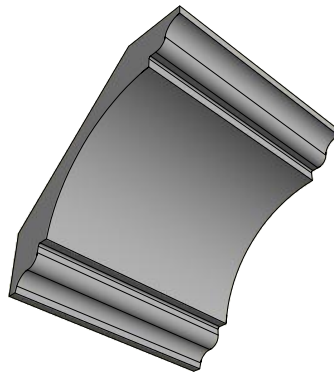

Description
 Crown Mould

Part Number
 CRO-09

-254-

Back

Scale 1



HOMESTEAD
 WOODWORKS

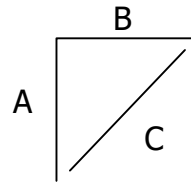
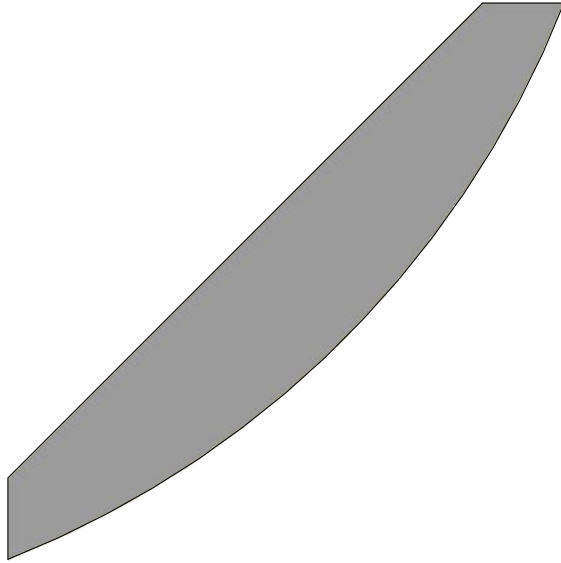

A: 2 7/8"
B: 2 7/8"
C: 4 1/8"

4/4

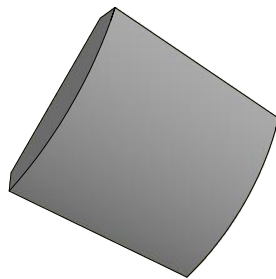

Description
Crown Mould

Part Number
CRO-10

-255-

Back

Scale 1 : 1



HOMESTEAD
WOODWORKS

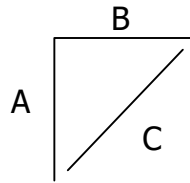
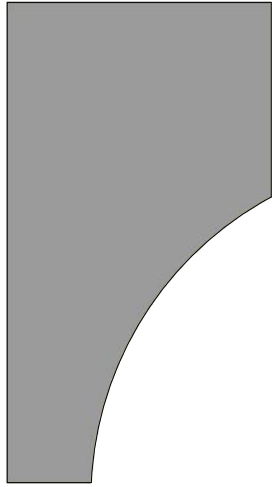

A: 2 1/2"
B: 1 3/8"
C: 2 7/8"

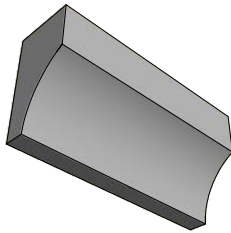

Description
Crown Mould

Part Number
CRO-11

-256-

Back

Scale 1 : 1



HOMESTEAD
WOODWORKS

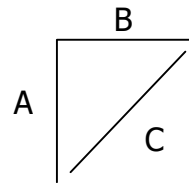
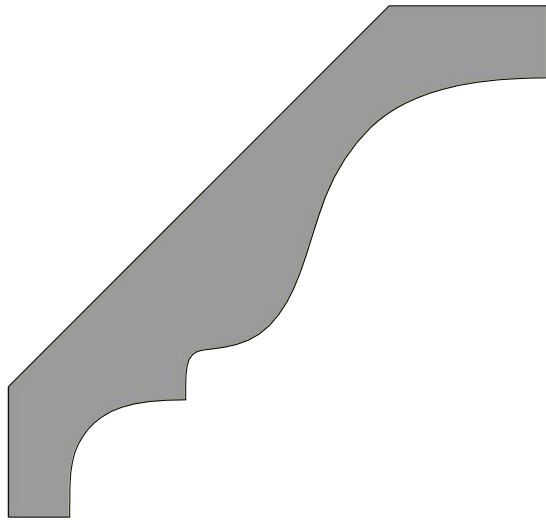

A: 2 11/16"
B: 2 13/16"
C: 3 7/8"

6/4

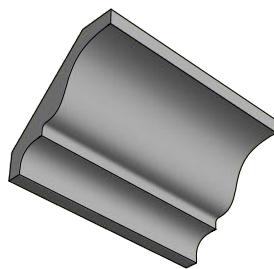

Description
Crown Mould

Part Number
CRO-12-A

-257-

Back

Scale 1 : 1



HOMESTEAD
WOODWORKS

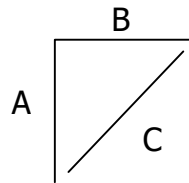
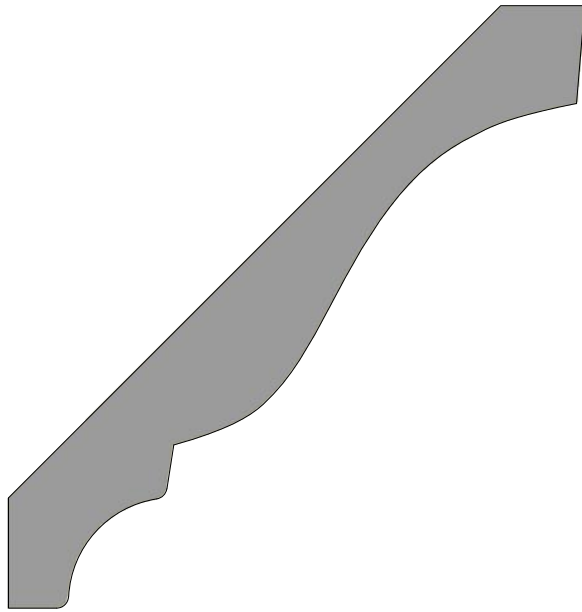

A: 3 1/8"
B: 3"
C: 4 5/16"

4/4

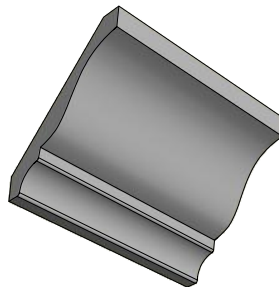

Description
Crown Mould

Part Number
CRO-12-B

-258-

Back

Scale 1 : 1



HOMESTEAD
WOODWORKS

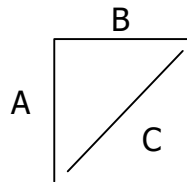
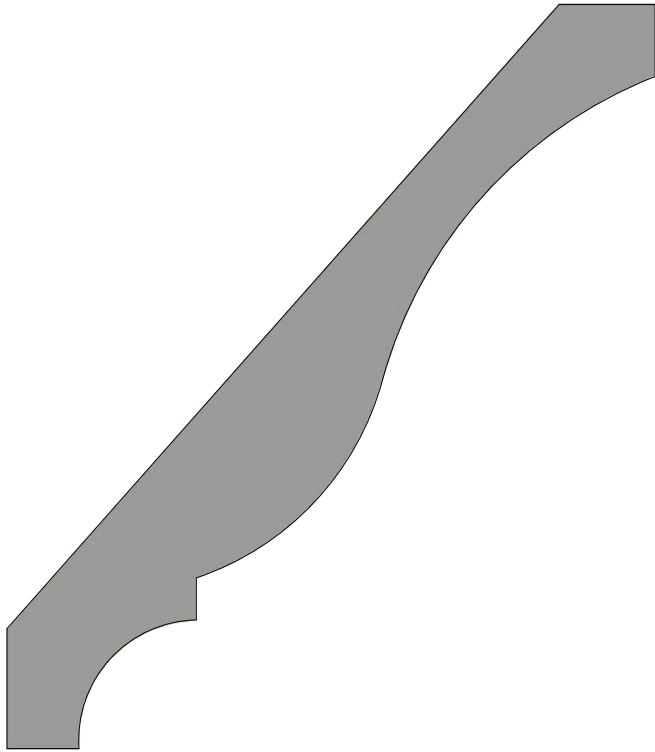

A: 3 7/8"
B: 3 3/8"
C: 5 1/8"

4/4

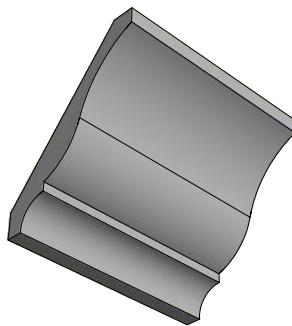

Description
Crown Mould

Part Number
CRO-12-C

-259-

Back

Scale 1 : 1



HOMESTEAD
WOODWORKS

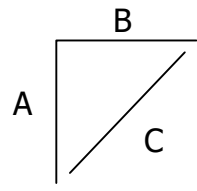
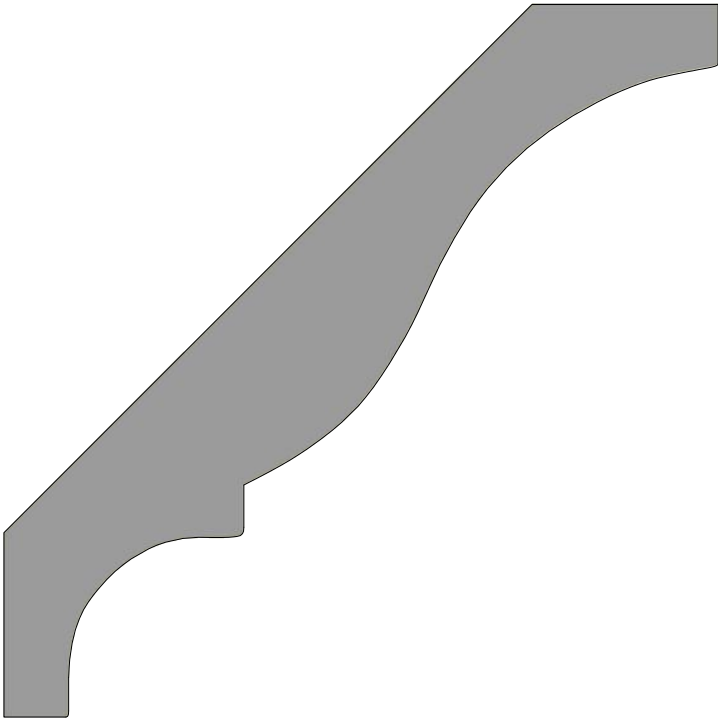

A: 3 11/16"
B: 3 3/4"
C: 5 1/4"

4/4

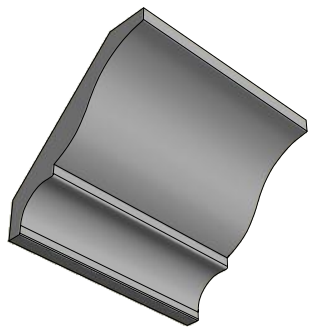

Description
Crown Mould

Part Number
CRO-12-D



-260-

Back

Scale 1 : 1

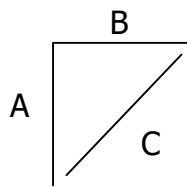
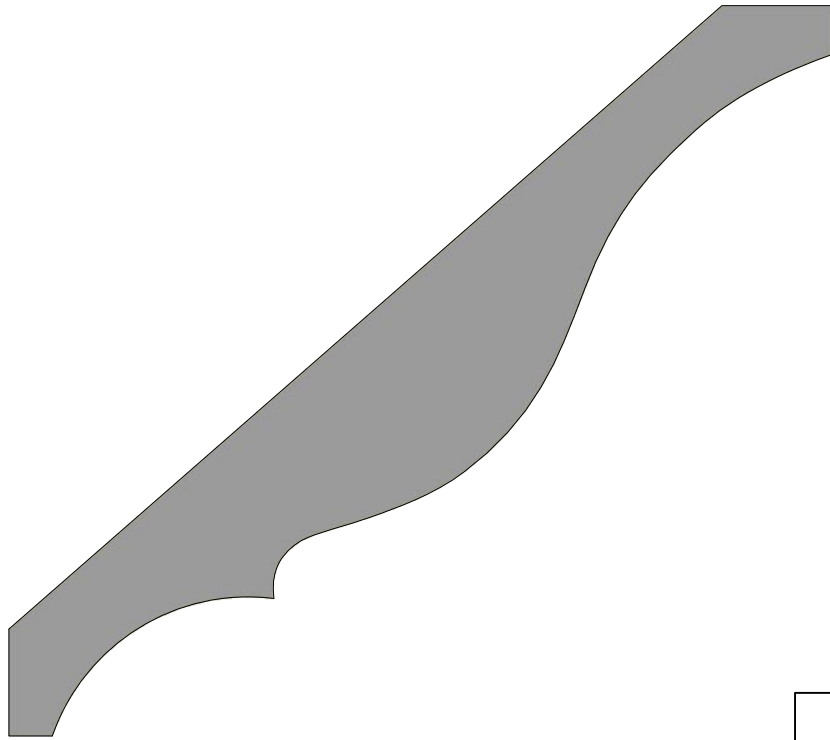

A: 3 13/16"
 B: 4 1/4"
 C: 5 3/4"

4/4

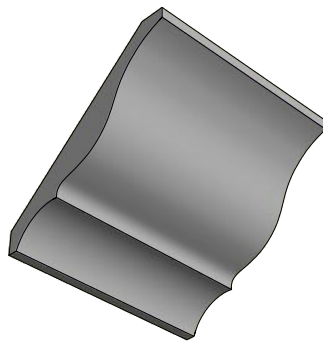

Description
 Crown Mould

Part Number
 CRO-12-E



-261-

Back

Scale 1 : 1

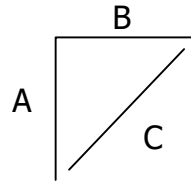
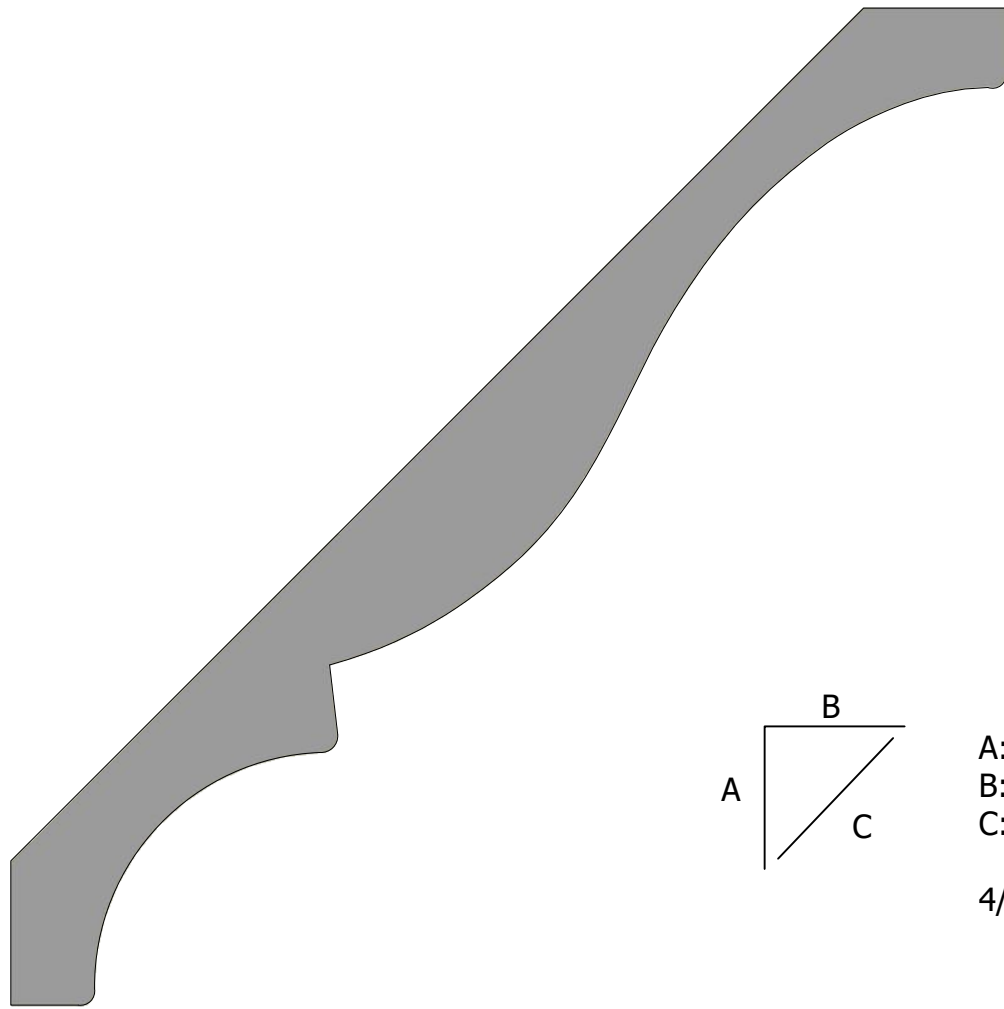

A: 5 3/16"
B: 5 3/16"
C: 7 5/16"

4/4

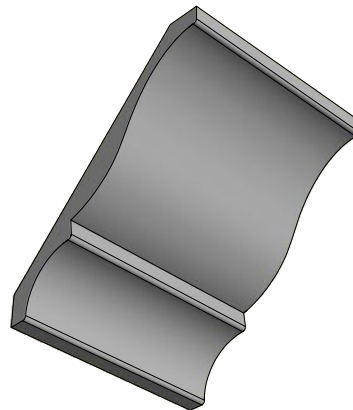

Description
Crown Mould

Part Number
CRO-12-F

-262-

Back

Scale 1 : 1



HOMESTEAD
WOODWORKS

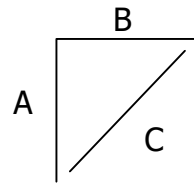
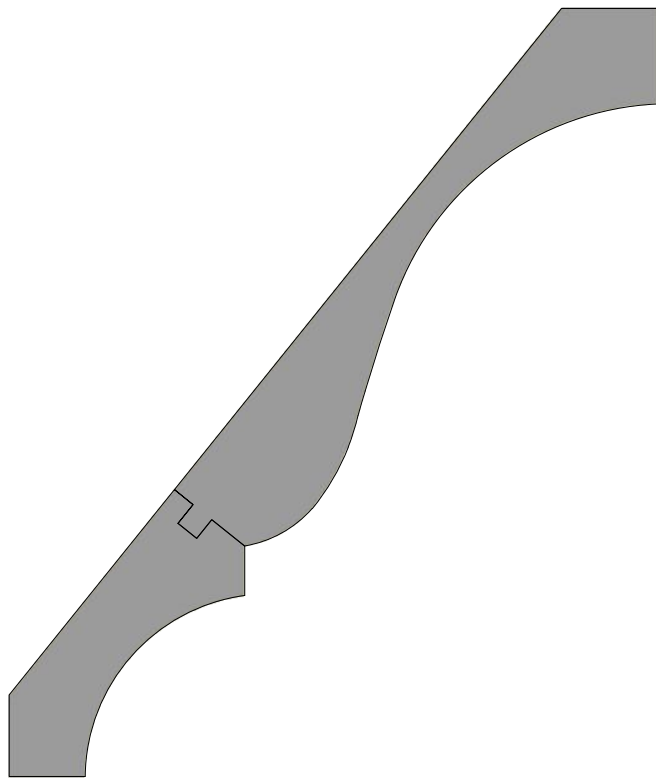

A: 8"
 B: 6 3/4"
 C: 10 7/16"

4/4

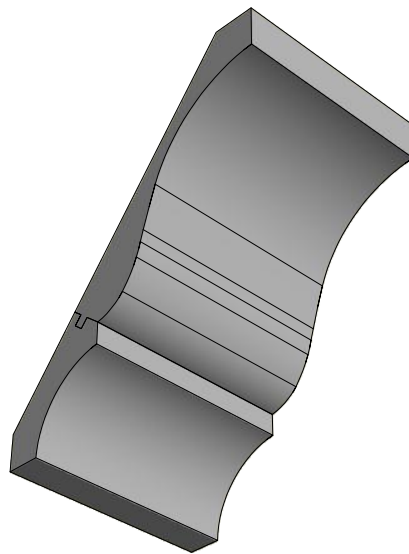

Description
 Crown Mould

Part Number
 CRO-12-G

-263-

Back

Scale 1 / 2



HOMESTEAD
 WOODWORKS

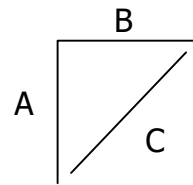
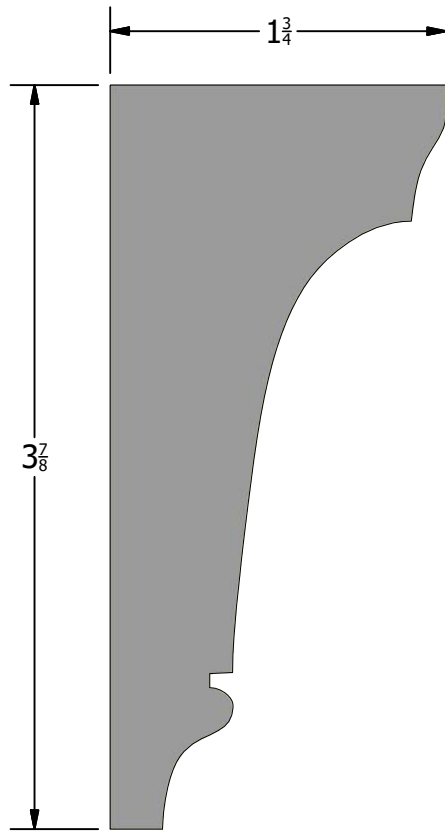

A: 3 7/8"
 B: 1 3/4"
 C: 4 1/4"

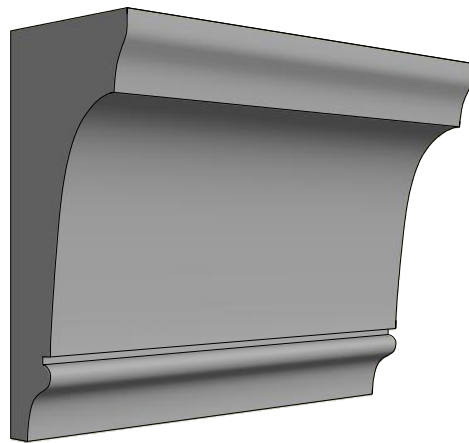

Description
 Crown Mould

Part Number
 CRO-13

-264-

Back

Scale 1



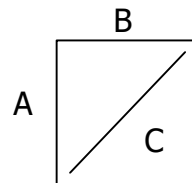
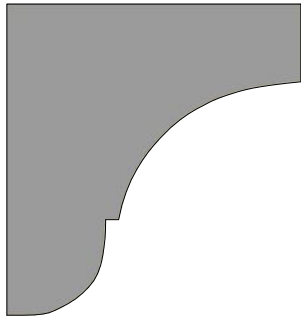

A: 1 5/8"
B: 1 1/2"
C: 2 1/4"

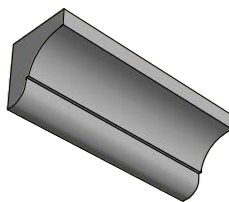

Description
Crown Mould

Part Number
CRO-14

-265-

Back

Scale 1 : 1



HOMESTEAD
WOODWORKS

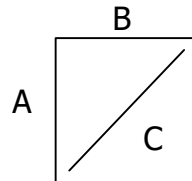
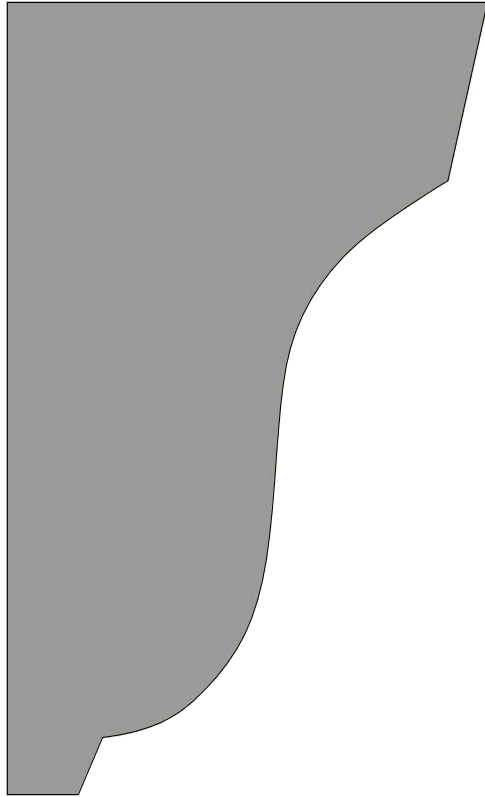

A: 4 1/8"
B: 2 1/2"
C: 4 13/16"

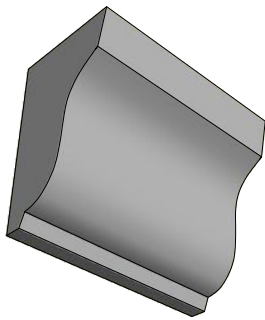

Description
Crown Mould

Part Number
CRO-15

-266-

Back

Scale 1 : 1



HOMESTEAD
WOODWORKS

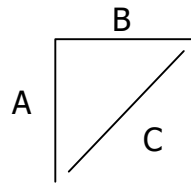
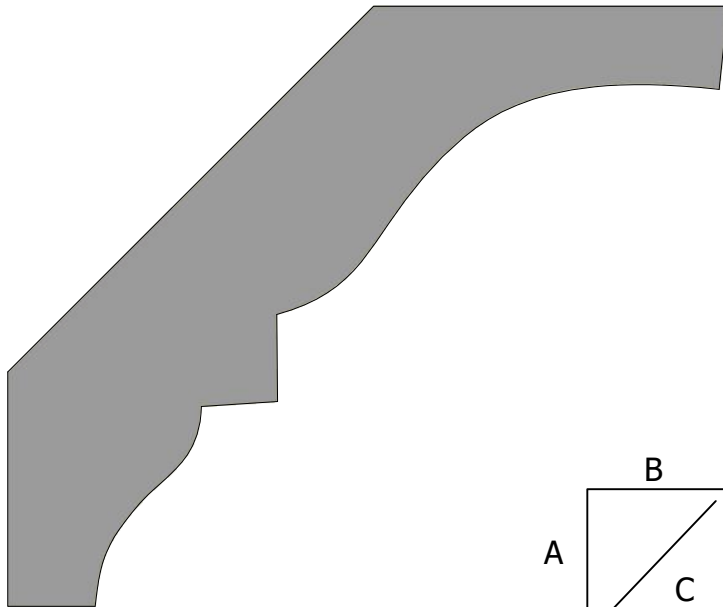

A: 3 1/8"
 B: 3 3/4"
 C: 4 7/8"

8/4

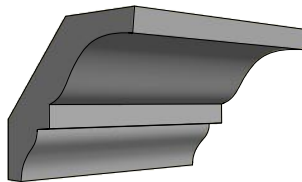

Description
 Crown Mould

Part Number
 CRO-16

-267-

Back

Scale 1 : 1



HOMESTEAD
 WOODWORKS

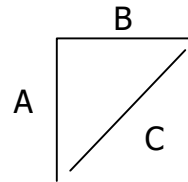
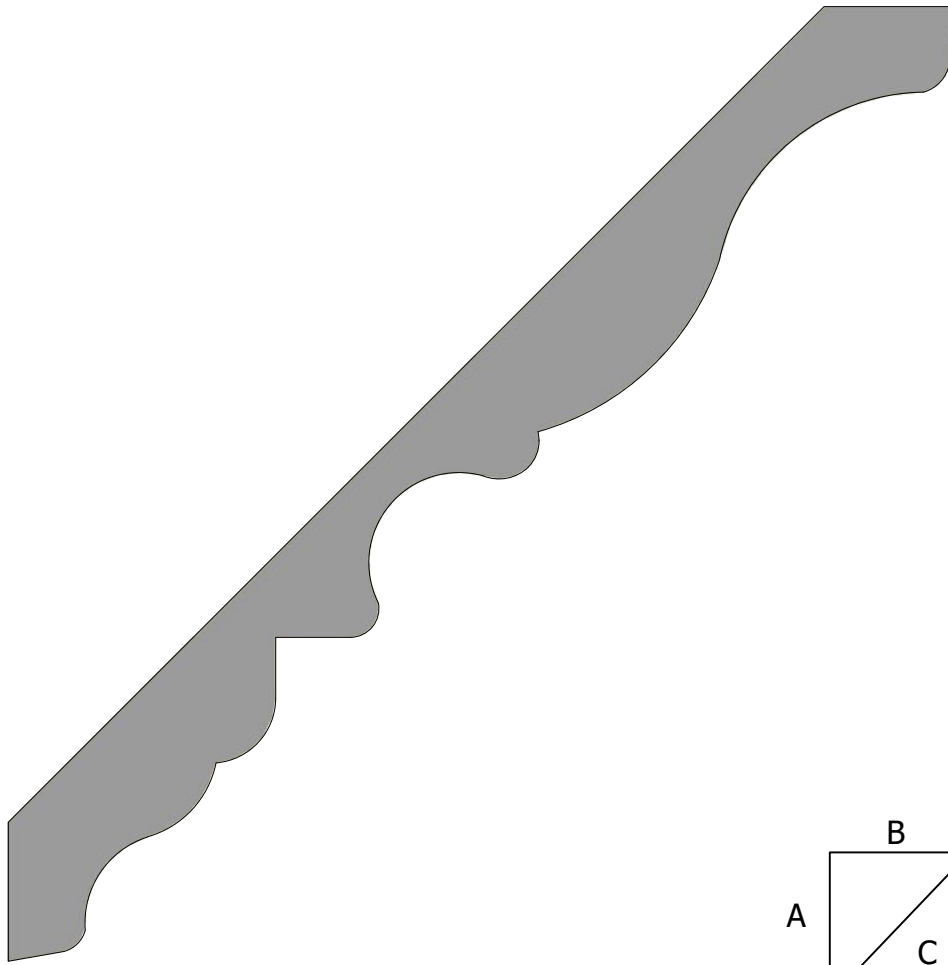

A: 5"
B: 4 15/16"
C: 7"

4/4

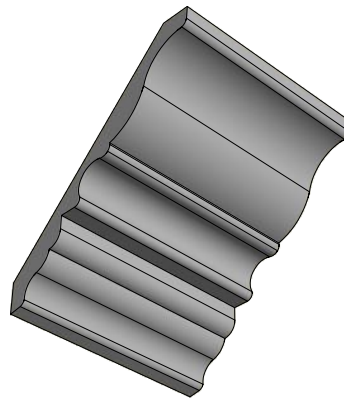

Description
Crown Mould

Part Number
CRO-17-A

-268-

Back

Scale 1 : 1



HOMESTEAD
WOODWORKS

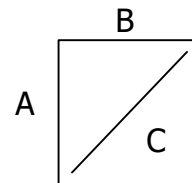
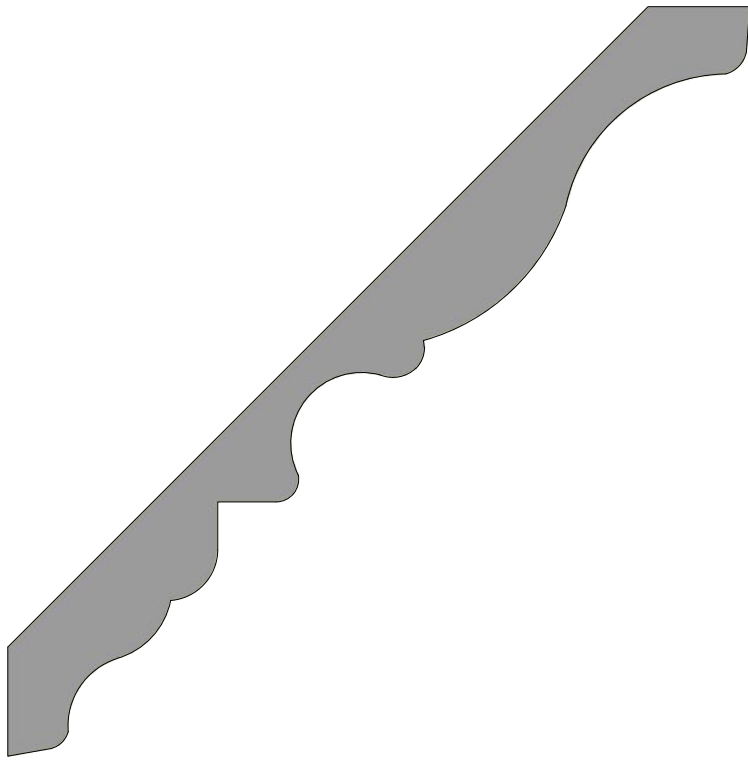

A: 3 7/8"
B: 3 7/8"
C: 5 1/2"

4/4

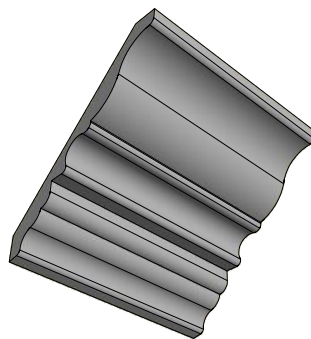

Description
Crown Mould

Part Number
CRO-17-B

-269-

Back

Scale 1 : 1



HOMESTEAD
WOODWORKS

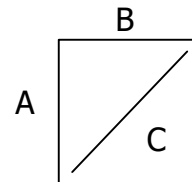
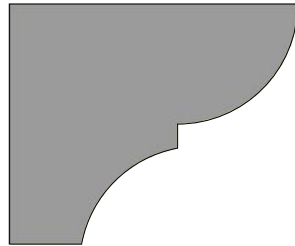

A: 1 1/4"
B: 1 1/2"
C: 1 15/16"

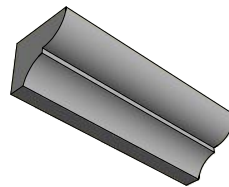

Description
Crown Mould

Part Number
CRO-18



-270-

Back

Scale 1 : 1

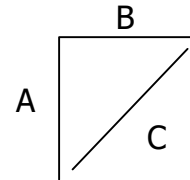
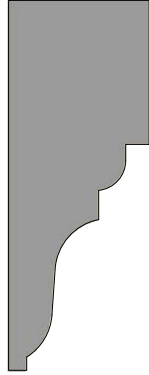

A: 1 15/16"
B: 3/4"
C: 2 1/16"

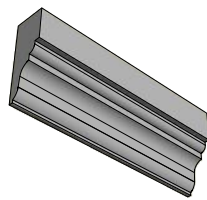

Description
Crown Mould

Part Number
CRO-19

-271-

Back

Scale 1 : 1



HOMESTEAD
WOODWORKS

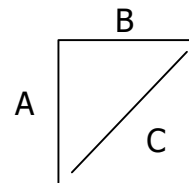
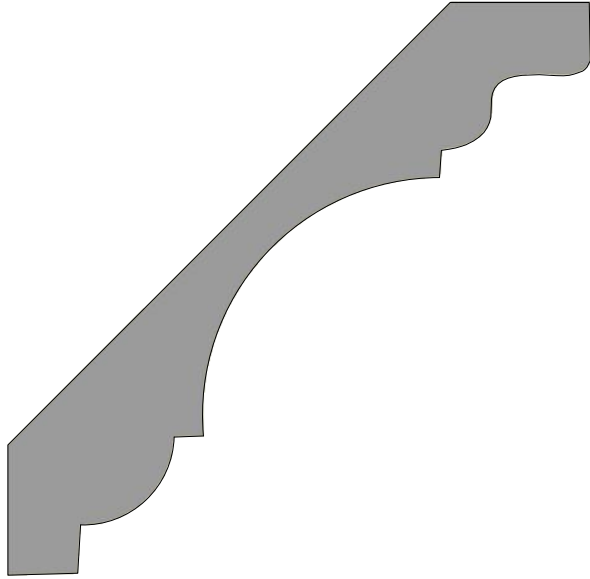

A: 3"
B: 3"
C: 4 1/4"

4/4

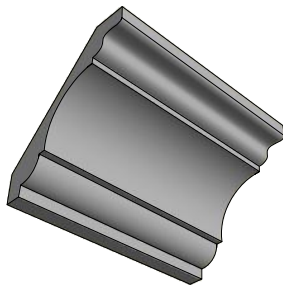

Description
Crown Mould

Part Number
CRO-20-A

-272-

Back

Scale 1 : 1



HOMESTEAD
WOODWORKS

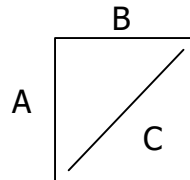
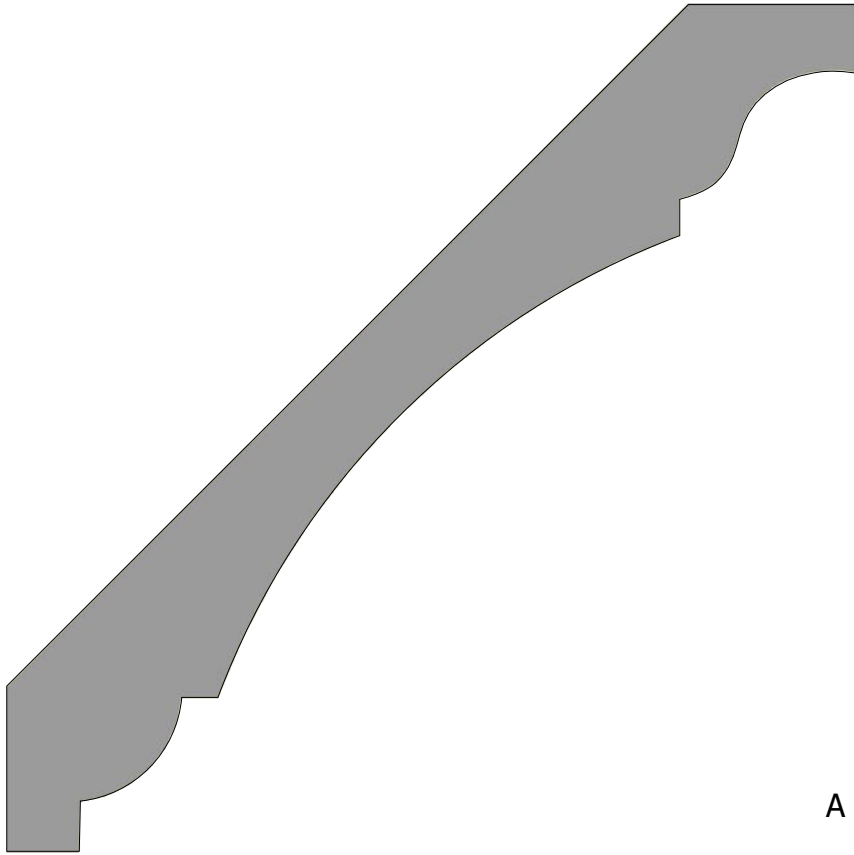

A: 4 7/16"
B: 4 7/16"
C: 6 1/4"

4/4

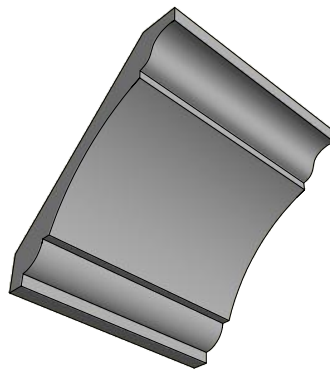

Description
Crown Mould

Part Number
CRO-20-B

-273-

Back

Scale 1 : 1



HOMESTEAD
WOODWORKS

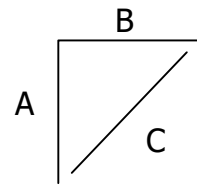
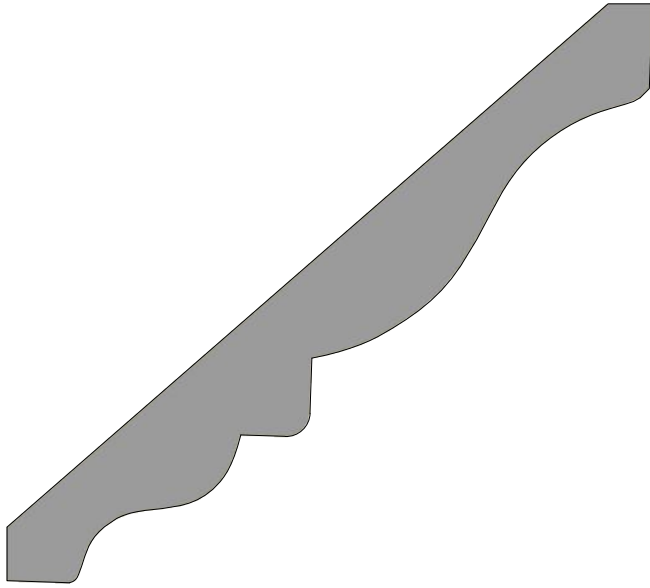

A: 3"
B: 3 3/8"
C: 4 1/2"
4/4

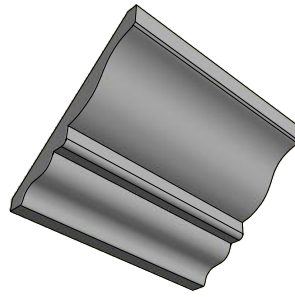

Description
Crown Mould

Part Number
CRO-21



HOMESTEAD
WOODWORKS

-274-

Back

Scale 1 : 1

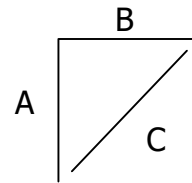
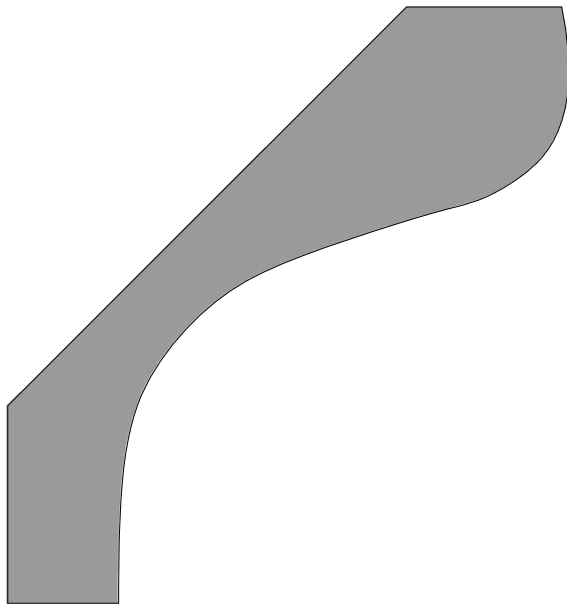

A: 3 1/8"
B: 2 7/8"
C: 4 1/4"
6/4

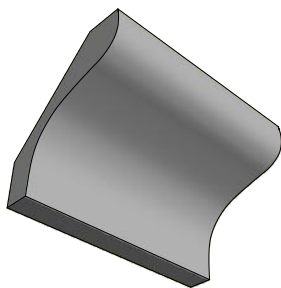

Description
Crown Mould

Part Number
CRO-22

-275-

Back

Scale 1 : 1



HOMESTEAD
WOODWORKS

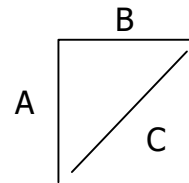
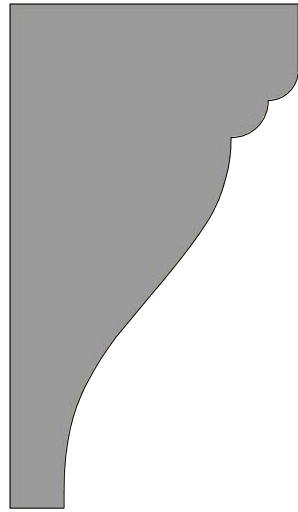

A: 2 5/8"
B: 1 1/2"
C: 3"

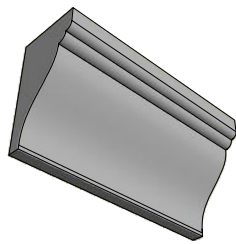

Description
Crown Mould

Part Number
CRO-23

-276-

Back

Scale 1 : 1



HOMESTEAD
WOODWORKS

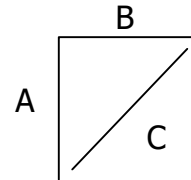
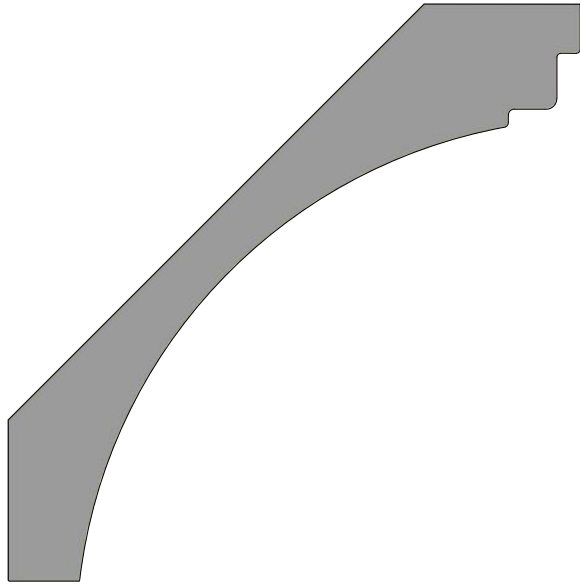

A: 3"
B: 3"
C: 4 1/4"

4/4

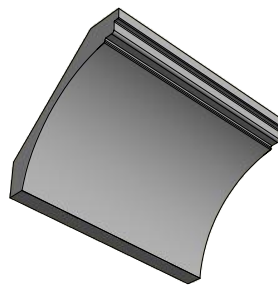

Description
Crown Mould

Part Number
CRO-24

-277-

Back

Scale 1 : 1



HOMESTEAD
WOODWORKS

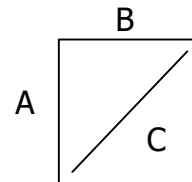
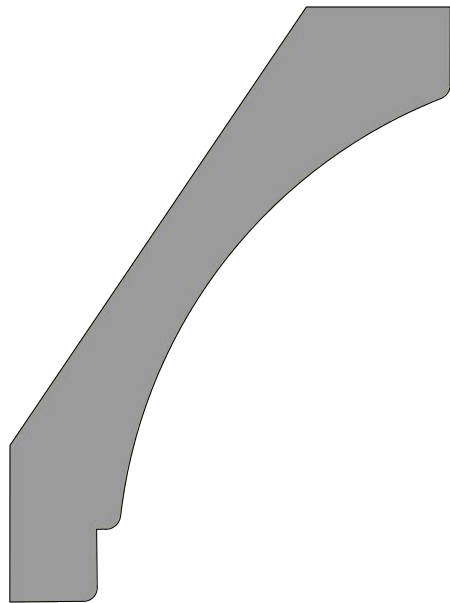

A: 2 5/16"
B: 3 1/8"
C: 3 7/8"

4/4

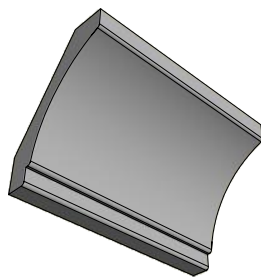

Description
Crown Mould

Part Number
CRO-25

-278-

Back

Scale 1 : 1



HOMESTEAD
WOODWORKS

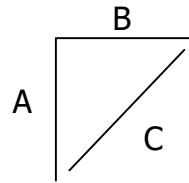
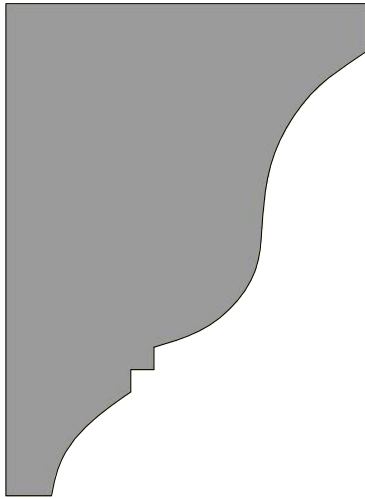

A: 2 9/16"
B: 1 7/8"
C: 3 3/16"

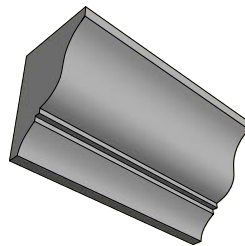

Description
Crown Mould

Part Number
CRO-26

-279-

Back

Scale 1 : 1



HOMESTEAD
WOODWORKS

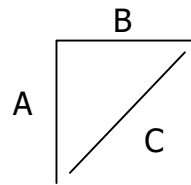
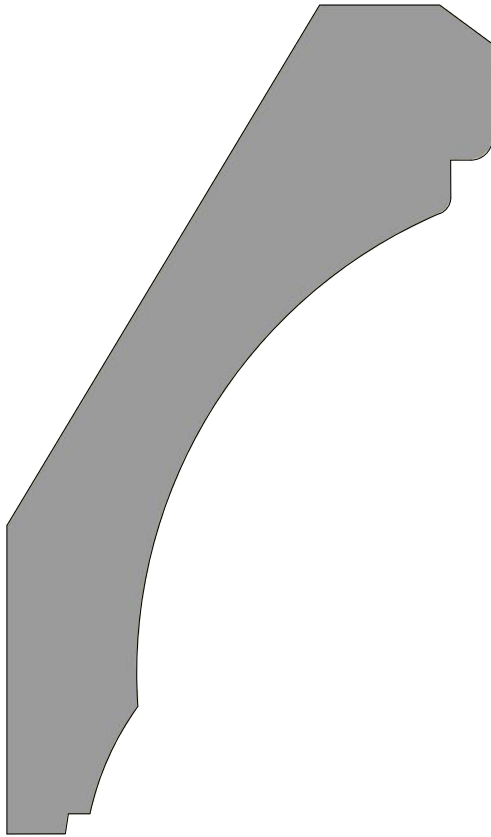

A: 4 15/16"
B: 2 1/2"
C: 4 13/16"

6/4

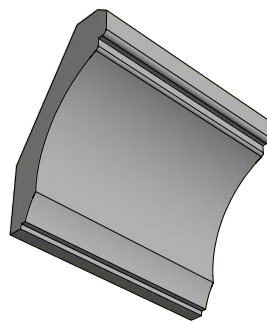

Description
Crown Mould

Part Number
CRO-27

-280-

Back

Scale 1 : 1



HOMESTEAD
WOODWORKS

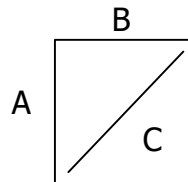
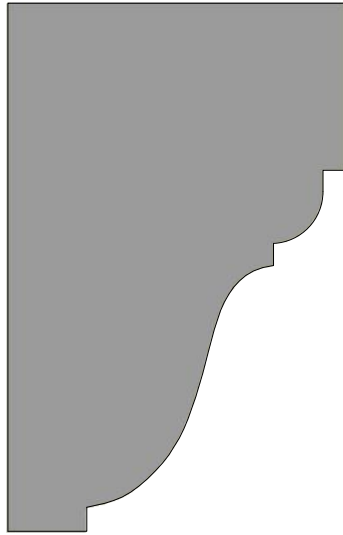

A: 2 3/4"
B: 1 3/4"
C: 3 1/4"

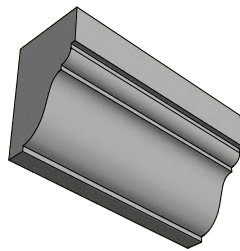

Description
Crown Mould

Part Number
CRO-28

-281-

Back

Scale 1 : 1



HOMESTEAD
WOODWORKS

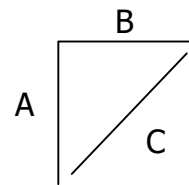
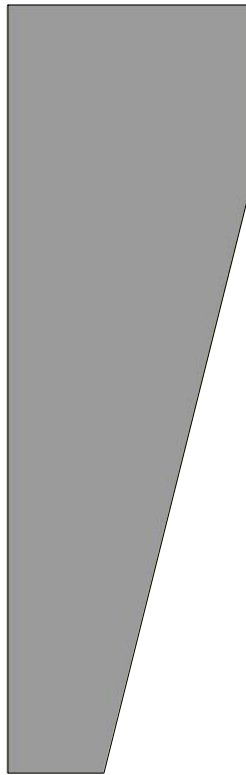

A: 4"
B: 1 3/4"
C: 4 13/16"

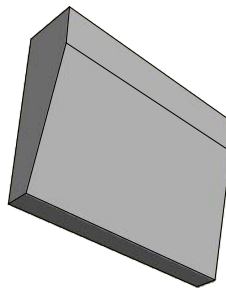

Description
Crown Mould

Part Number
CRO-29

-282-

Back

Scale 1 : 1



HOMESTEAD
WOODWORKS

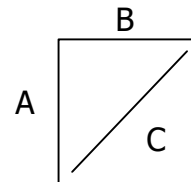
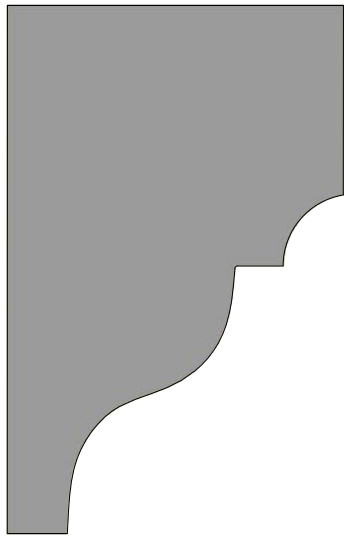

A: 2 3/4"
B: 1 3/4"
C: 3 1/4"

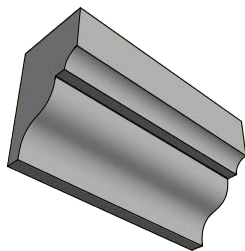

Description
Crown Mould

Part Number
CRO-30

-283-

Back

Scale 1 : 1



HOMESTEAD
WOODWORKS

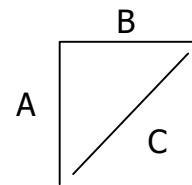
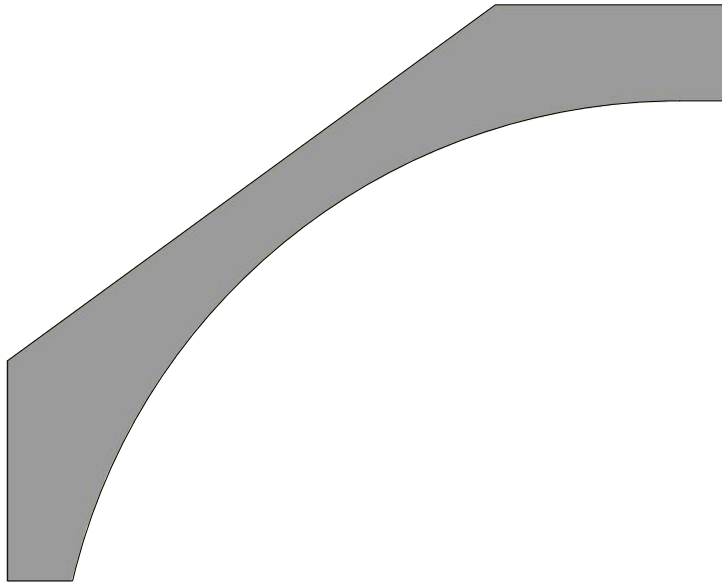

A: 3 "
B: 3 3/4"
C: 4 13/16"

6/4

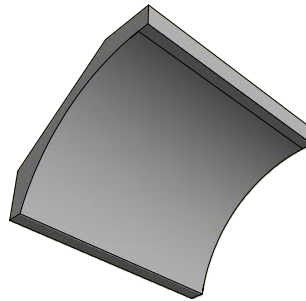

Description
Crown Mould

Part Number
CRO-31

-284-

Back

Scale 1 : 1



HOMESTEAD
WOODWORKS

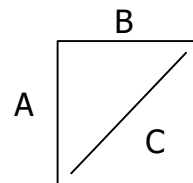
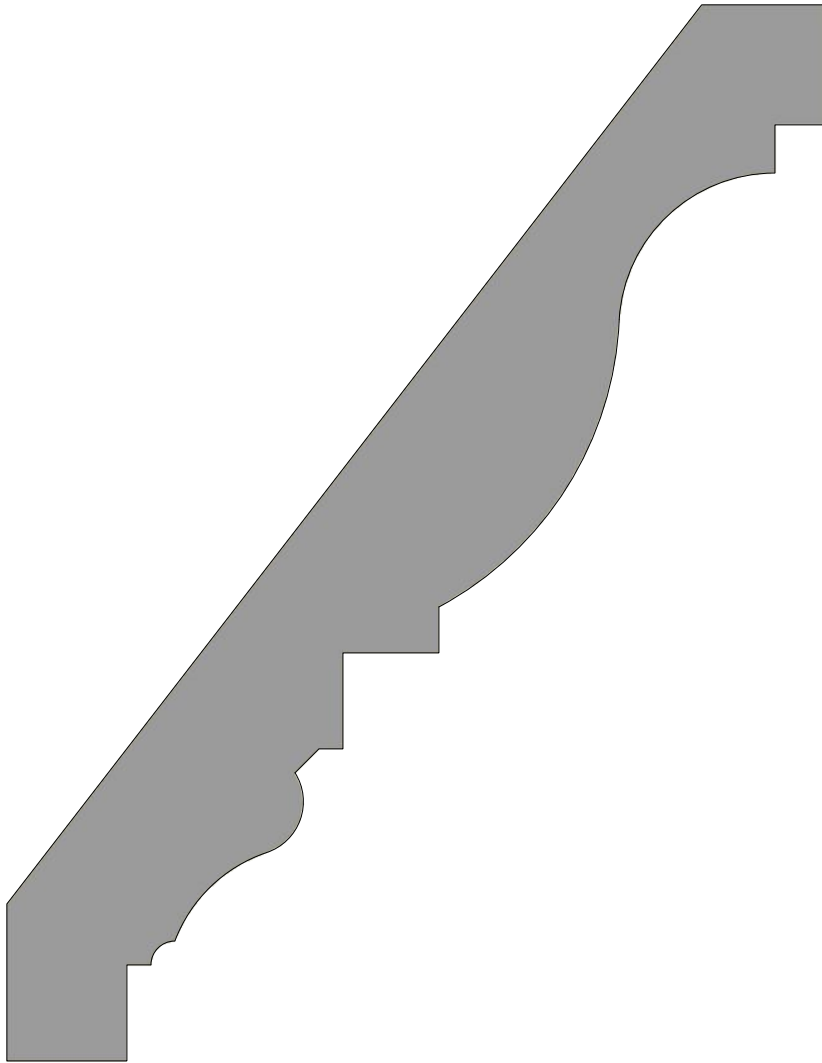

A: 5 1/2"
B: 4 1/4"
C: 6 15/16"

4/4

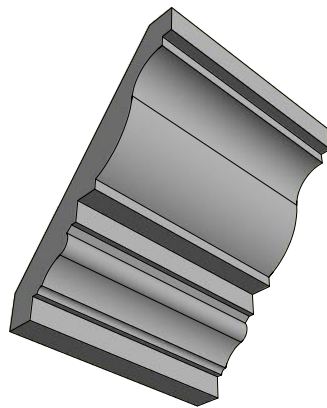

Description
Crown Mould

Part Number
CRO-32

-285-

Back

Scale 1 : 1



HOMESTEAD
WOODWORKS

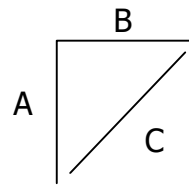
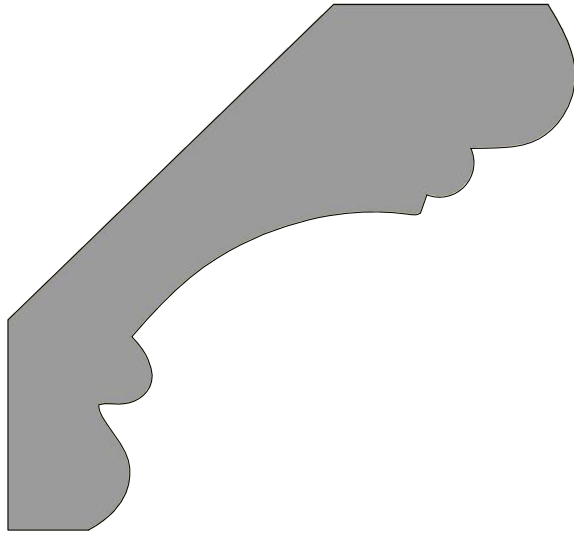

A: 2 3/4"
B: 2 13/16"
C: 3 15/16"

6/4

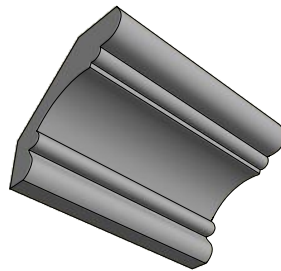

Description
Crown Mould

Part Number
CRO-33

-286-

Back

Scale 1 : 1



HOMESTEAD
WOODWORKS

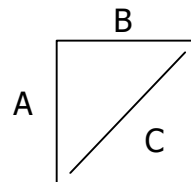
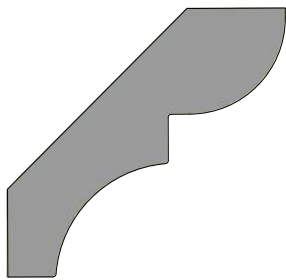

A: 1 3/8"
B: 1 7/16"
C: 2"

4/4

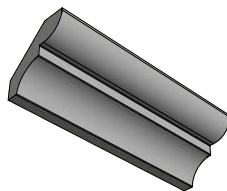

Description
Crown Mould

Part Number
CRO-34

-287-

Back

Scale 1 : 1



HOMESTEAD
WOODWORKS

Description

Part Number

-287-

Back

Scale



HOMESTEAD
WOODWORKS

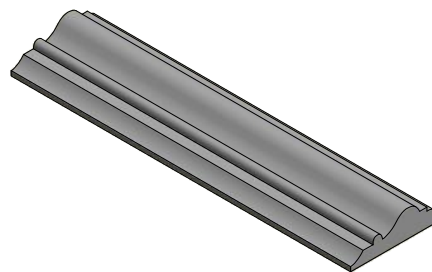
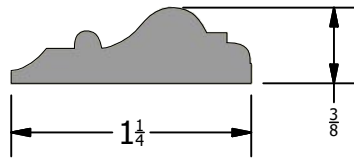

Description
Panel Mould

Part Number
Pan-01



-288-

Back

Scale 1 : 1

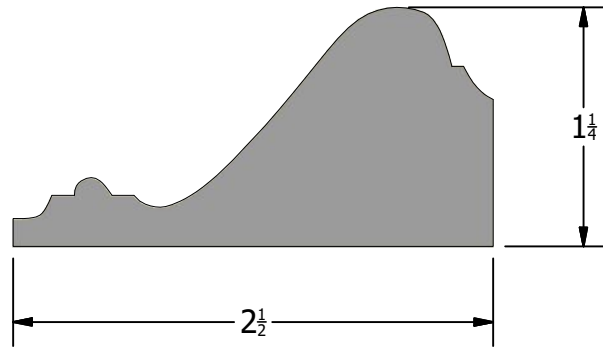

Description
Panel Mould

Part Number
Pan-02

-289-

Back

Scale 1 : 1



HOMESTEAD
WOODWORKS

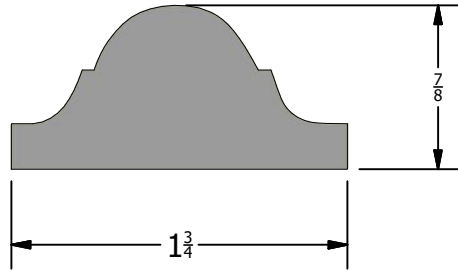

Description
Panel Mould

Part Number
Pan-03

-290-

Back

Scale 1 : 1



HOMESTEAD
WOODWORKS

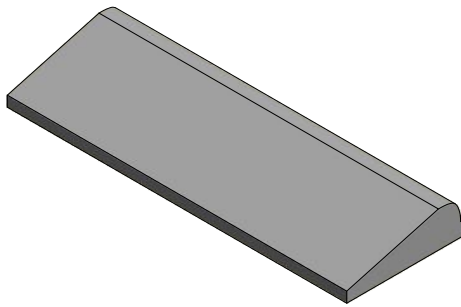
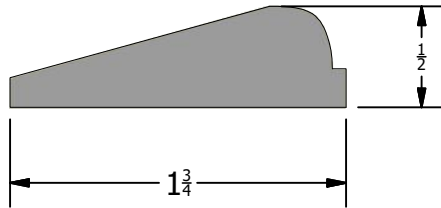

Description
Panel Mould

Part Number
Pan-04

-291-

Back

Scale 1 : 1



HOMESTEAD
WOODWORKS

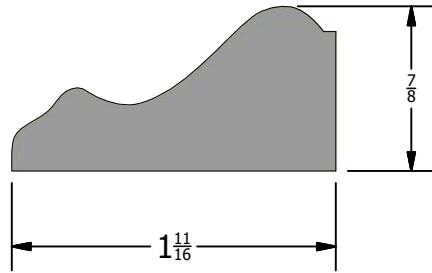

Description
Panel Mould

Part Number
Pan-05

-292-

Back

Scale 1 : 1



HOMESTEAD
WOODWORKS

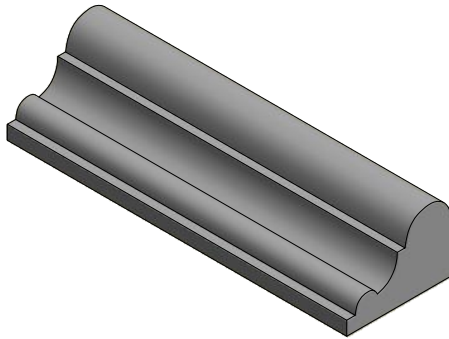
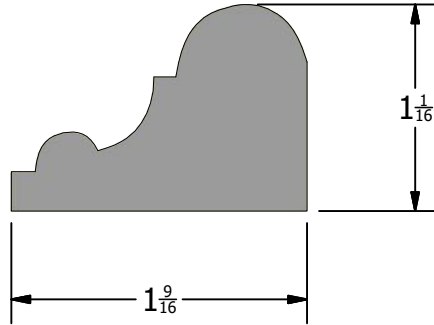

Description
Panel Mould

Part Number
Pan-06

-293-

Back

Scale 1 : 1



HOMESTEAD
WOODWORKS

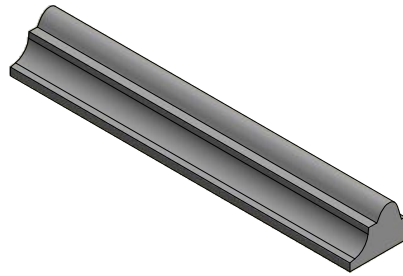
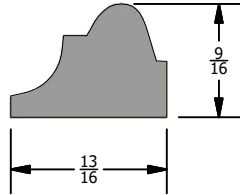

Description
Panel Mould

Part Number
Pan-07

-294-

Back

Scale 1 : 1



HOMESTEAD
WOODWORKS

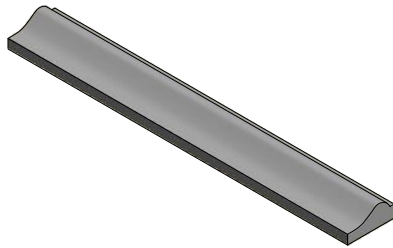
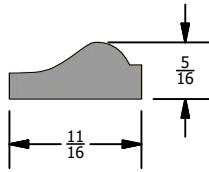

Description
Panel Mould

Part Number
Pan-08

-295-

Back

Scale 1 : 1



HOMESTEAD
WOODWORKS

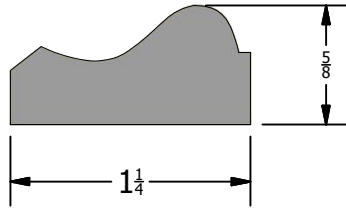

Description
Panel Mould

Part Number
Pan-09

-296-

Back

Scale 1 : 1



HOMESTEAD
WOODWORKS

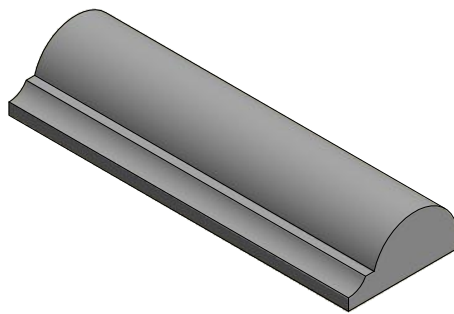
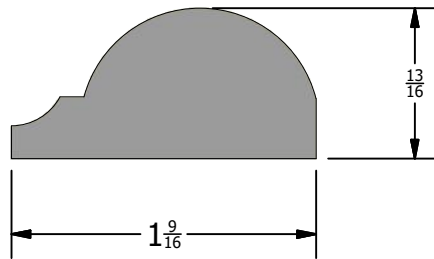

Description
Panel Mould

Part Number
Pan-10

-297-

Back

Scale 1 : 1



HOMESTEAD
WOODWORKS

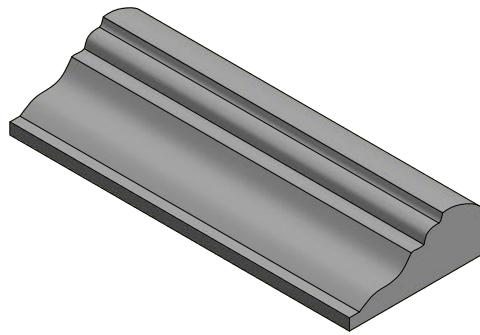
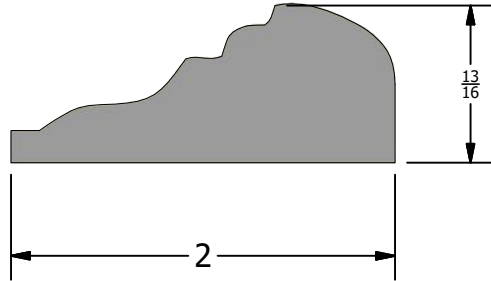

Description
Panel Mould

Part Number
Pan-11

-298-

Back

Scale 1 : 1



HOMESTEAD
WOODWORKS

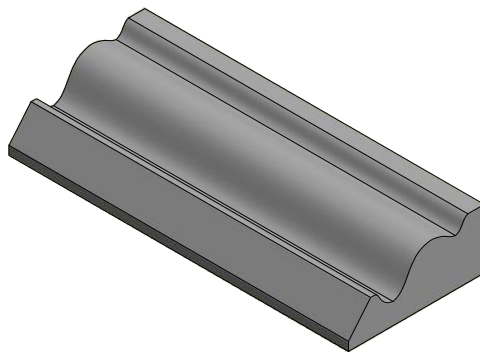
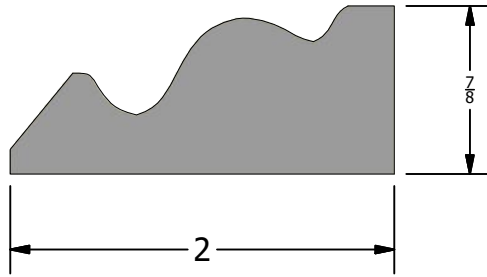

Description
Panel Mould

Part Number
Pan-12

-299-

Back

Scale 1 : 1



HOMESTEAD
WOODWORKS

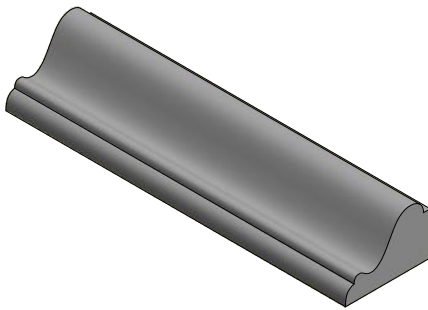
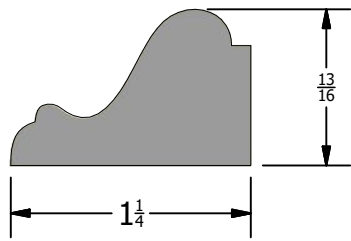

Description
Panel Mould

Part Number
Pan-13

-300-

Back

Scale 1 : 1



HOMESTEAD
WOODWORKS

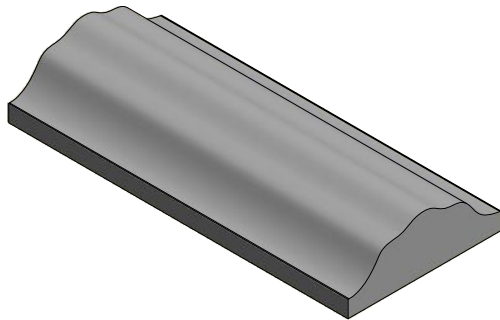
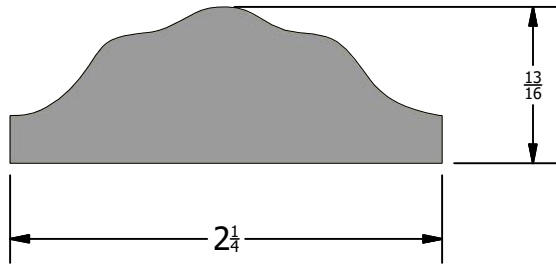

Description
Panel Mould

Part Number
Pan-14

-301-

Back

Scale 1 : 1



HOMESTEAD
WOODWORKS

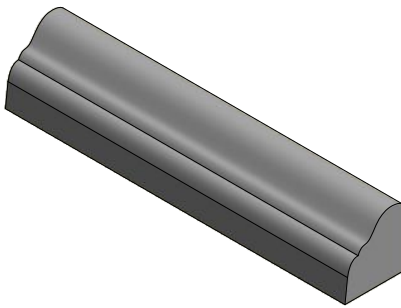
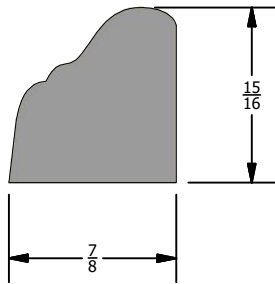

Description
Panel Mould

Part Number
Pan-15

-302-

Back

Scale 1 : 1



HOMESTEAD
WOODWORKS

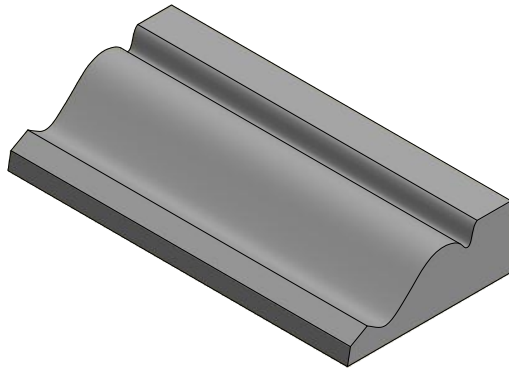
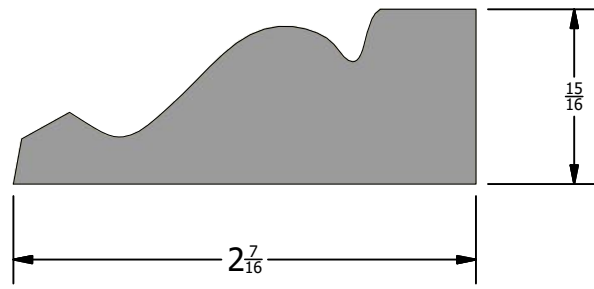

Description
Panel Mould

Part Number
Pan-16

-303-

Back

Scale 1 : 1



HOMESTEAD
WOODWORKS

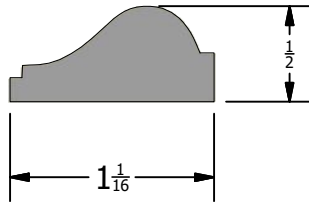

Description
Panel Mould

Part Number
Pan-17

-304-

Back

Scale 1 : 1



HOMESTEAD
WOODWORKS

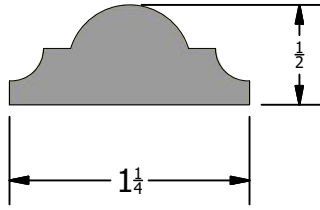

Description
Panel Mould

Part Number
Pan-18

-305-

Back

Scale 1 : 1



HOMESTEAD
WOODWORKS

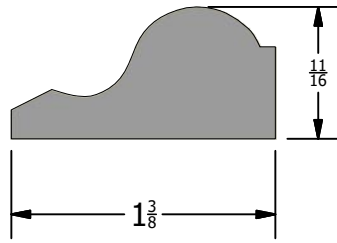

Description
Panel Mould

Part Number
Pan-19

-306-

Back

Scale 1 : 1



HOMESTEAD
WOODWORKS

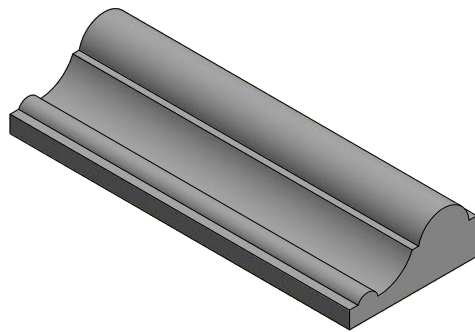
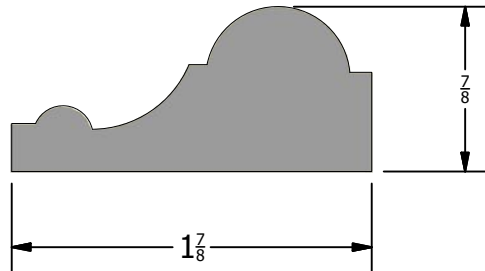

Description
Panel Mould

Part Number
Pan-20

-307-

Back

Scale 1 : 1



HOMESTEAD
WOODWORKS

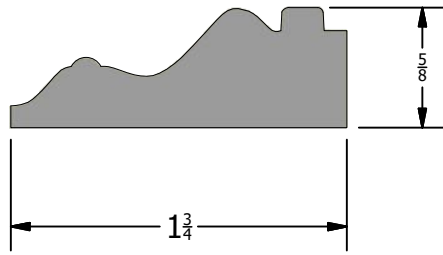

Description
Panel Mould

Part Number
Pan-21

-308-

Back

Scale 1 : 1

HOMESTEAD
WOODWORKS

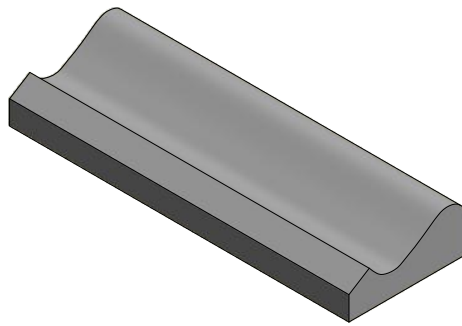
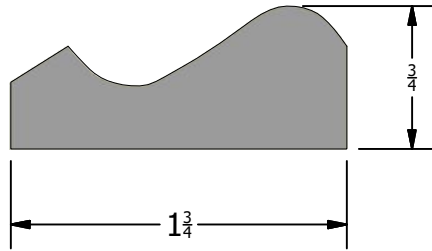

Description
Panel Mould

Part Number
Pan-22

-309-

Back

Scale 1 : 1



HOMESTEAD
WOODWORKS

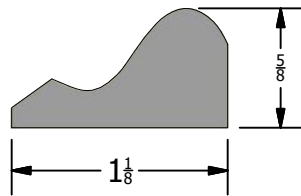

Description
Panel Mould

Part Number
Pan-23

-310-

Back

Scale 1 : 1



HOMESTEAD
WOODWORKS

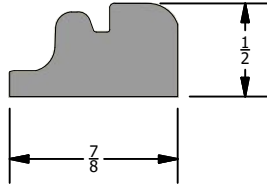

Description
Panel Mould

Part Number
Pan-24

-311-

Back

Scale 1 : 1



HOMESTEAD
WOODWORKS

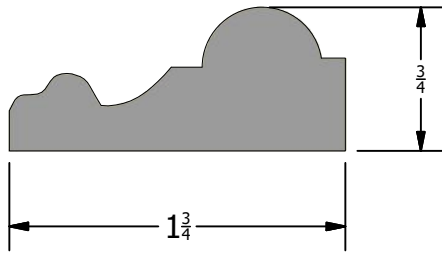

Description
Panel Mould

Part Number
Pan-25

-312-

Back

Scale 1 : 1



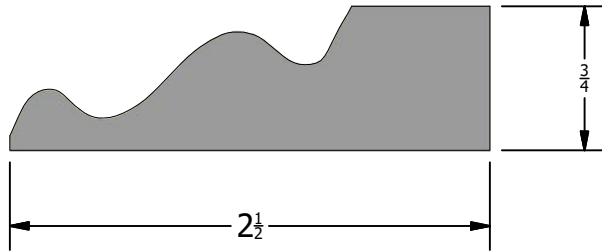

Description
Panel Mould

Part Number
Pan-26

-313-

Back

Scale 1 : 1



HOMESTEAD
WOODWORKS

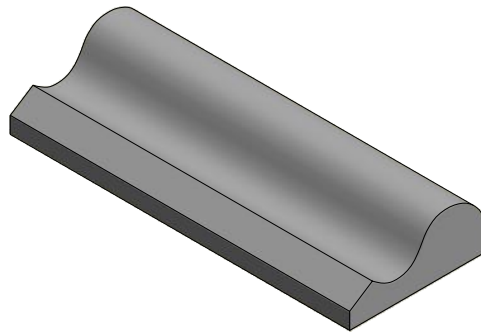
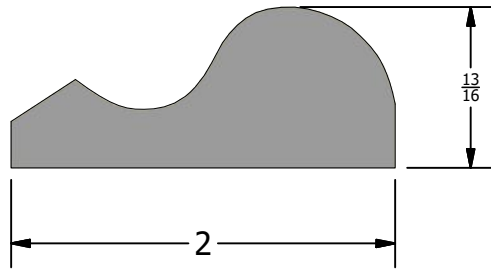

Description
Panel Mould

Part Number
Pan-27

-314-

Back

Scale 1 : 1



HOMESTEAD
WOODWORKS

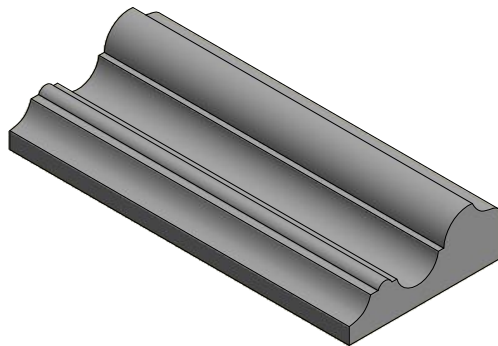
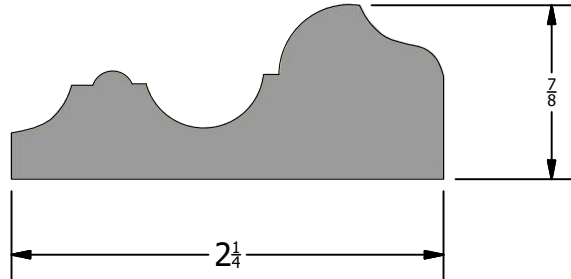

Description
Panel Mould

Part Number
Pan-28

-315-

Back

Scale 1 : 1



HOMESTEAD
WOODWORKS

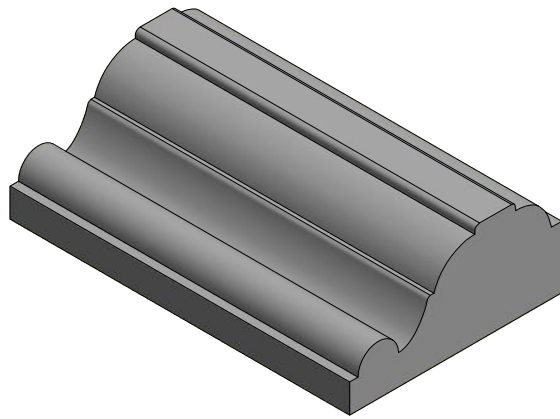
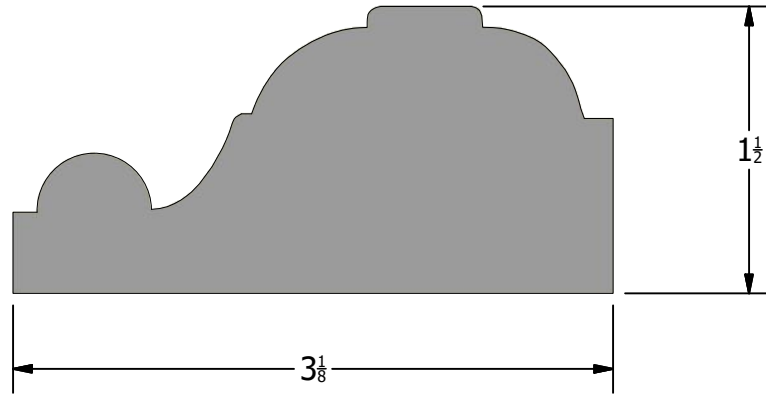

Description Panel Mould		Part Number Pan-29	 HOMESTEAD WOODWORKS
-316-	Back	Scale 1 : 1	

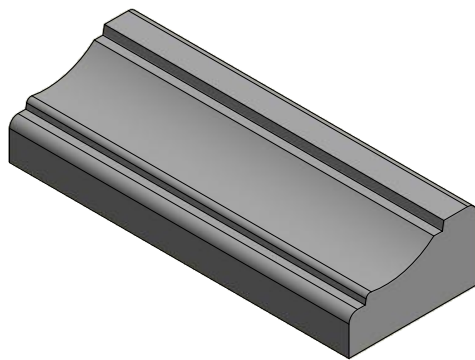
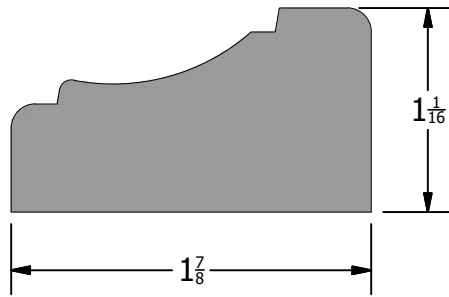

Description
Panel Mould

Part Number
Pan-30

-317-

Back

Scale 1 : 1



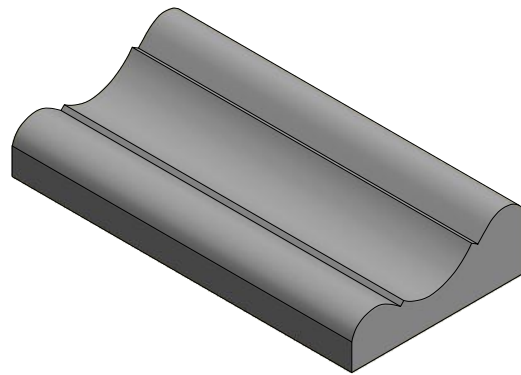
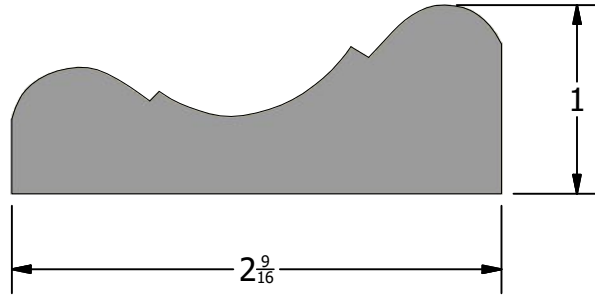

Description
Panel Mould

Part Number
Pan-31



-318-

Back

Scale 1 : 1

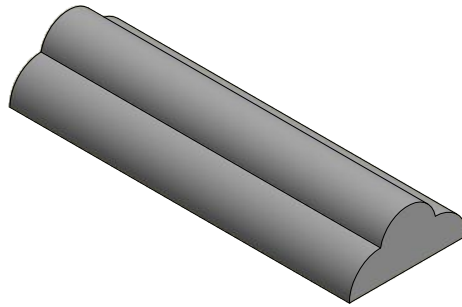
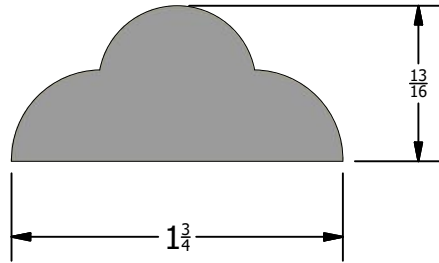

Description
Panel Mould

Part Number
Pan-32

-319-

Back

Scale 1 : 1



HOMESTEAD
WOODWORKS

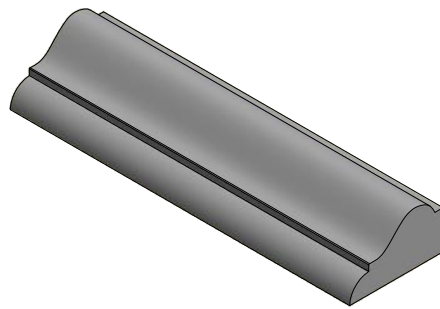
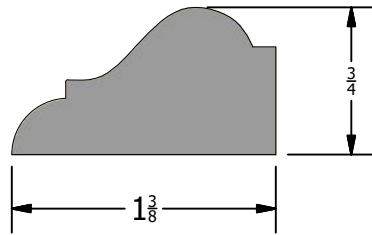

Description
Panel Mould

Part Number
Pan-33

-320-

Back

Scale 1 : 1



HOMESTEAD
WOODWORKS

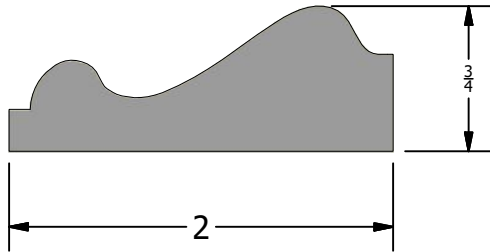

Description
Panel Mould

Part Number
Pan-34

-321-

Back

Scale 1 : 1



HOMESTEAD
WOODWORKS

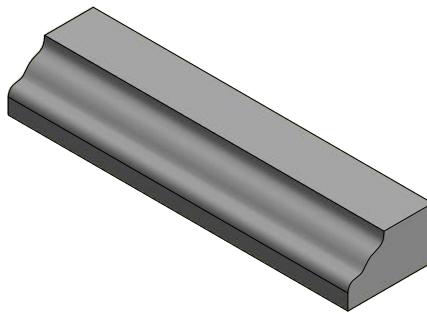
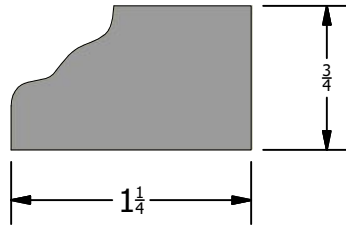

Description
Panel Mould

Part Number
Pan-35

-322-

Back

Scale 1 : 1



HOMESTEAD
WOODWORKS

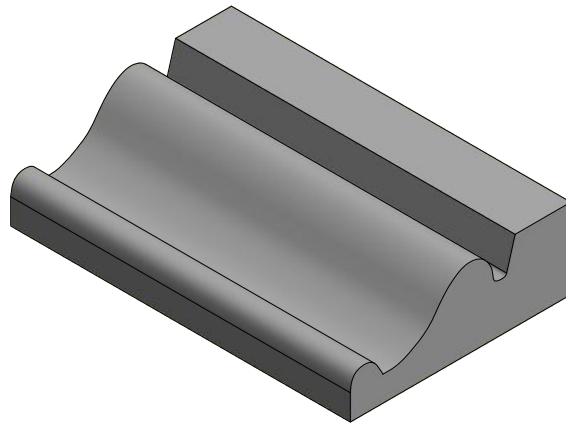
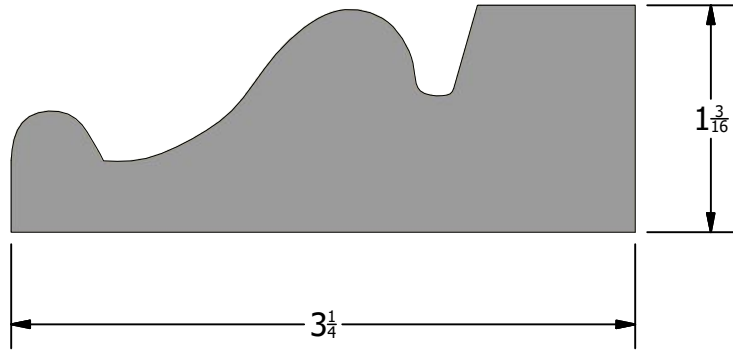

Description
Panel Mould

Part Number
Pan-36-A

-323-

Back

Scale 1 : 1



HOMESTEAD
WOODWORKS

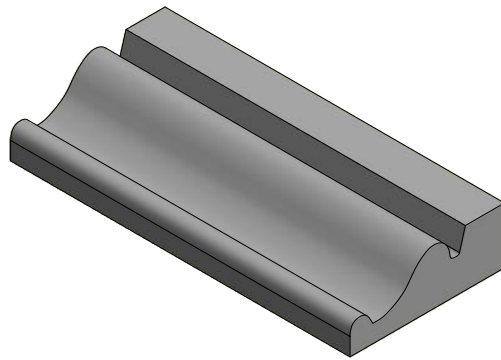
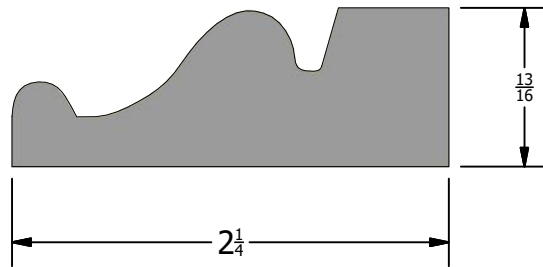

Description
Panel Mould

Part Number
Pan-36-B

-324-

Back

Scale 1 : 1



HOMESTEAD
WOODWORKS

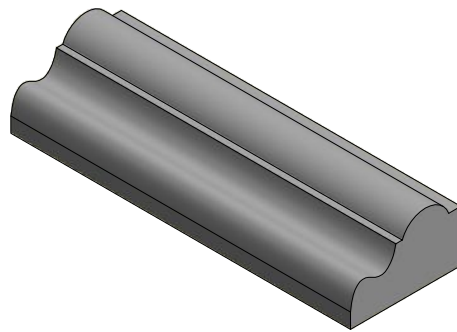
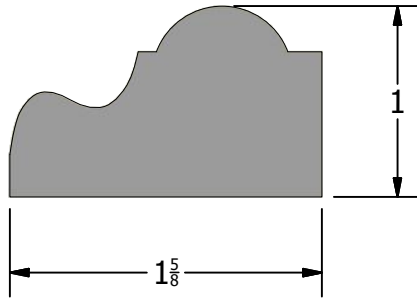

Description
Panel Mould

Part Number
Pan-37

-325-

Back

Scale 1 : 1



HOMESTEAD
WOODWORKS

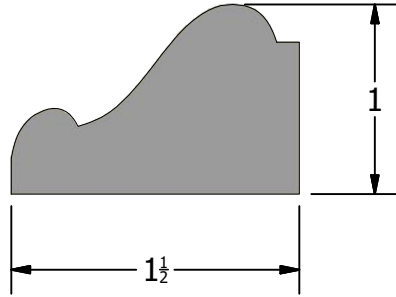

Description
Panel Mould

Part Number
Pan-38

-326-

Back

Scale 1 : 1



HOMESTEAD
WOODWORKS

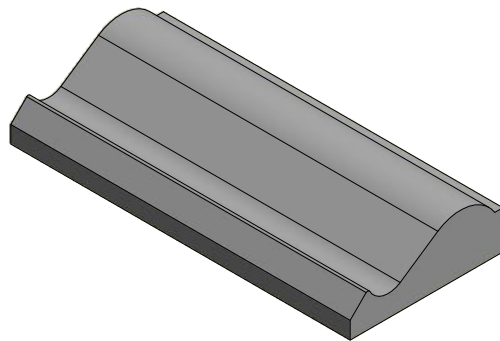
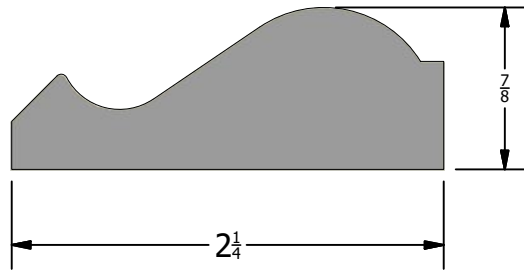

Description
Panel Mould

Part Number
Pan-39

-327-

Back

Scale 1 : 1



HOMESTEAD
WOODWORKS

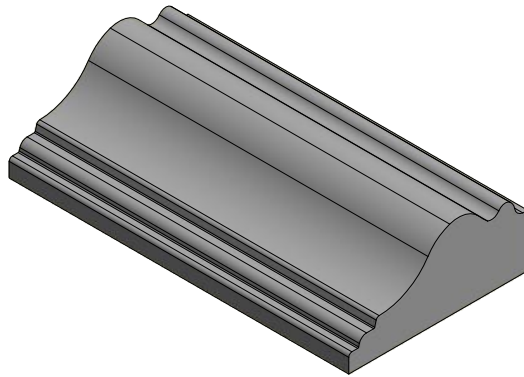
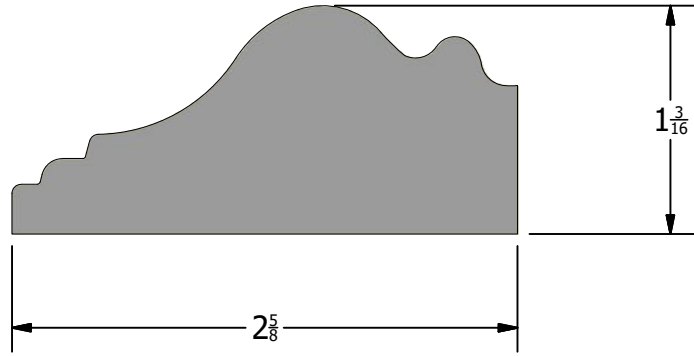

Description
Panel Mould

Part Number
Pan-40

-328-

Back

Scale 1 : 1



HOMESTEAD
WOODWORKS

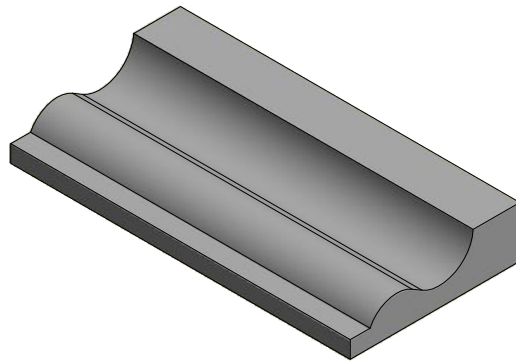
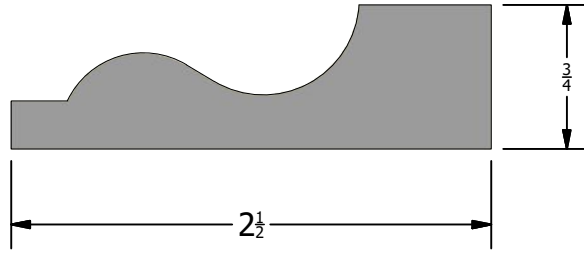

Description
Panel Mould

Part Number
Pan-41

-329-

Back

Scale 1 : 1



HOMESTEAD
WOODWORKS

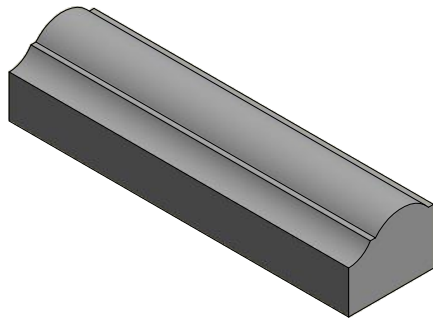
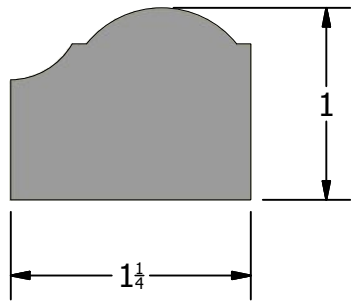

Description
Panel Mould

Part Number
Pan-42

-330-

Back

Scale 1 : 1



HOMESTEAD
WOODWORKS

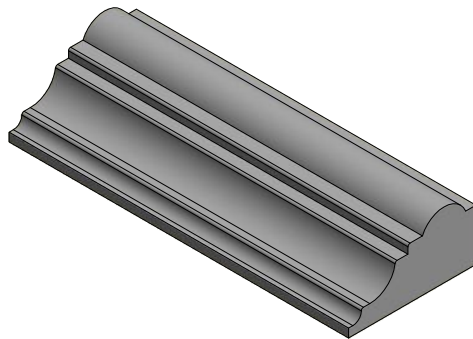
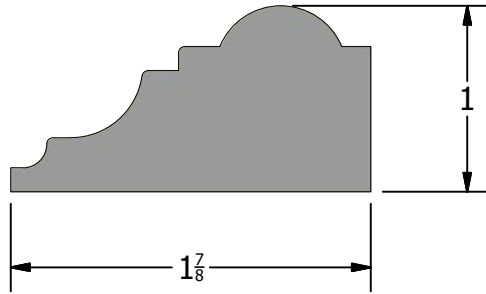

Description
Panel Mould

Part Number
Pan-43

-331-

Back

Scale 1 : 1



HOMESTEAD
WOODWORKS

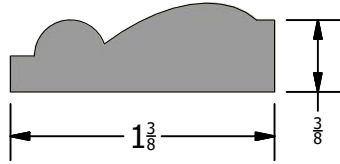

Description
Panel Mould

Part Number
Pan-44

-332-

Back

Scale 1 : 1



HOMESTEAD
WOODWORKS

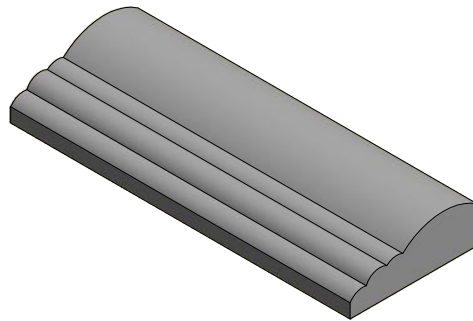
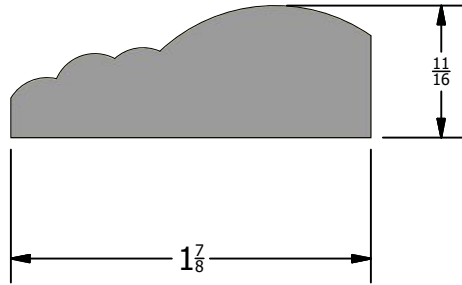

Description
Panel Mould

Part Number
Pan-45

-333-

Back

Scale 1 : 1



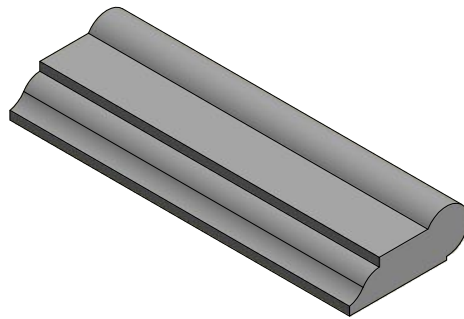
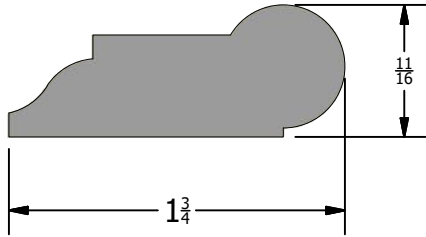

Description
Panel Mould

Part Number
Pan-46

-334-

Back

Scale 1 : 1



HOMESTEAD
WOODWORKS

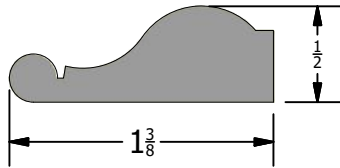

Description
Panel Mould

Part Number
Pan-47

-335-

Back

Scale 1 : 1



HOMESTEAD
WOODWORKS

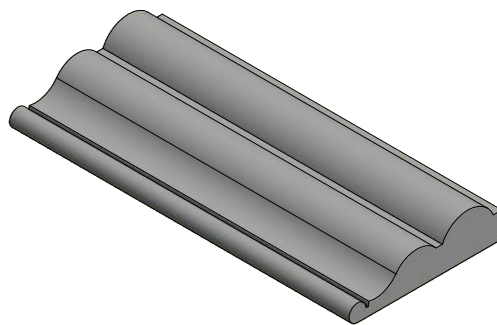
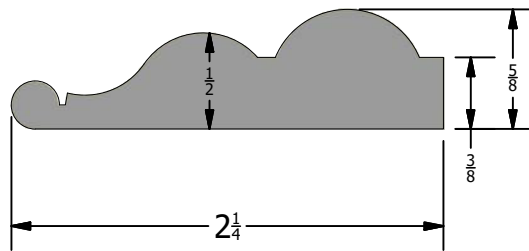

Description
Panel Mould

Part Number
Pan-47-B

-338-

Back

Scale 1

HOMESTEAD
WOODWORKS

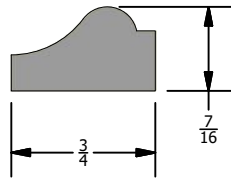

Description
Panel Mould

Part Number
Pan-48

-336-

Back

Scale 1 : 1



HOMESTEAD
WOODWORKS

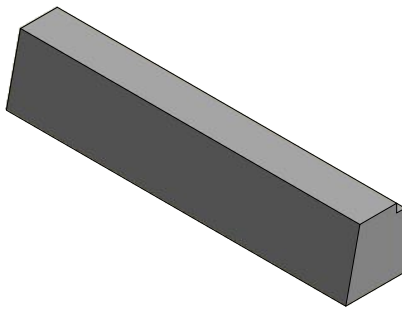
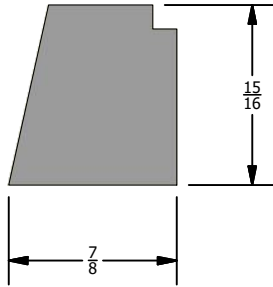

Description
Panel Mould

Part Number
Pan-49-A

-337-

Back

Scale 1 : 1



HOMESTEAD
WOODWORKS

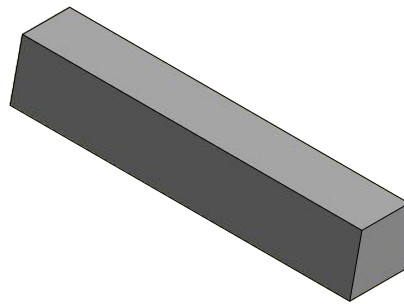
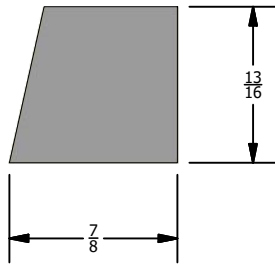

Description
Panel Mould

Part Number
Pan-49-B



-338-

Back

Scale 1 : 1

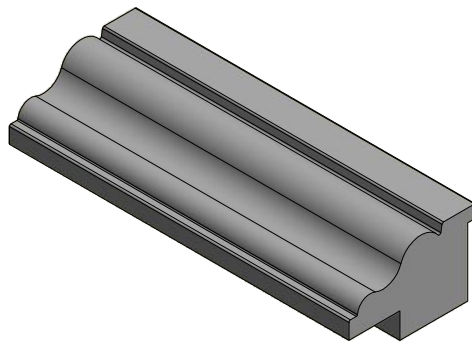
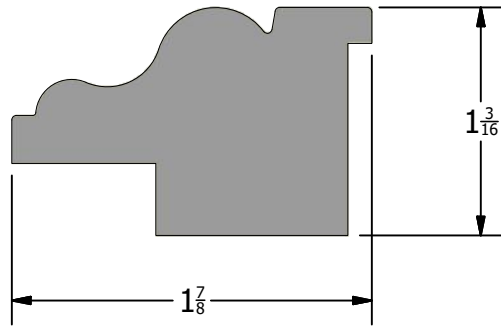

Description
Panel Mould

Part Number
Pan-50

-339-

Back

Scale 1 : 1



HOMESTEAD
WOODWORKS

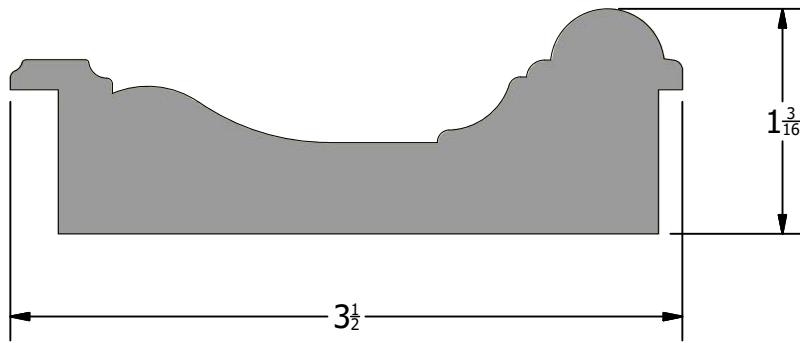

Description
Panel Mould

Part Number
Pan-51

-340-

Back

Scale 1 : 1



HOMESTEAD
WOODWORKS

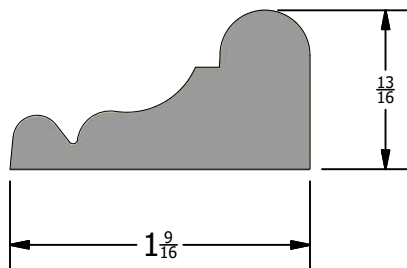

Description
Panel Mould

Part Number
Pan-52

-341-

Back

Scale 1 : 1



HOMESTEAD
WOODWORKS

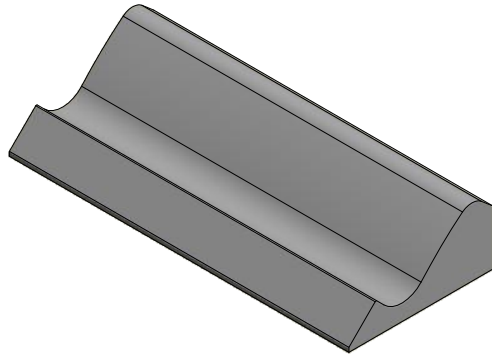
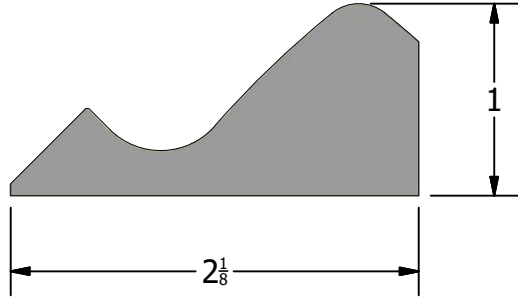

Description
Panel Mould

Part Number
Pan-53

-342-

Back

Scale 1 : 1



HOMESTEAD
WOODWORKS

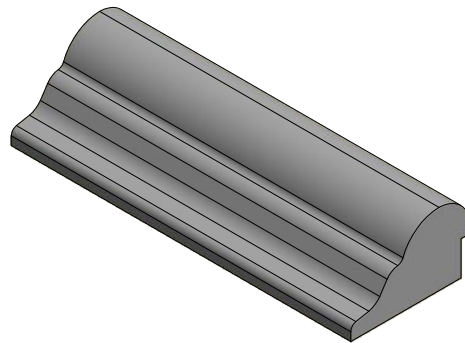
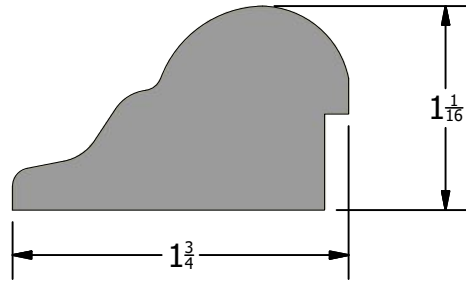

Description
Panel Mould

Part Number
Pan-54

-343-

Back

Scale 1 : 1



HOMESTEAD
WOODWORKS

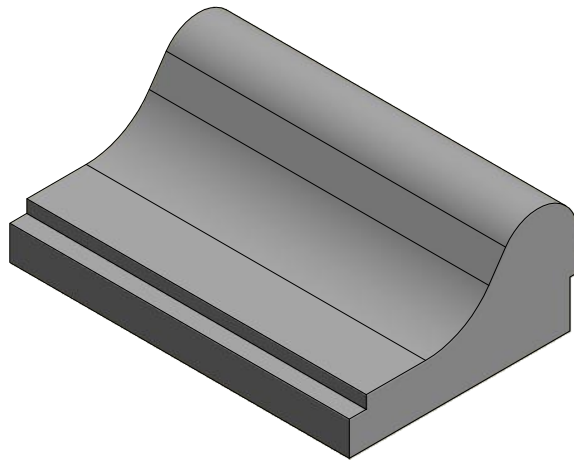
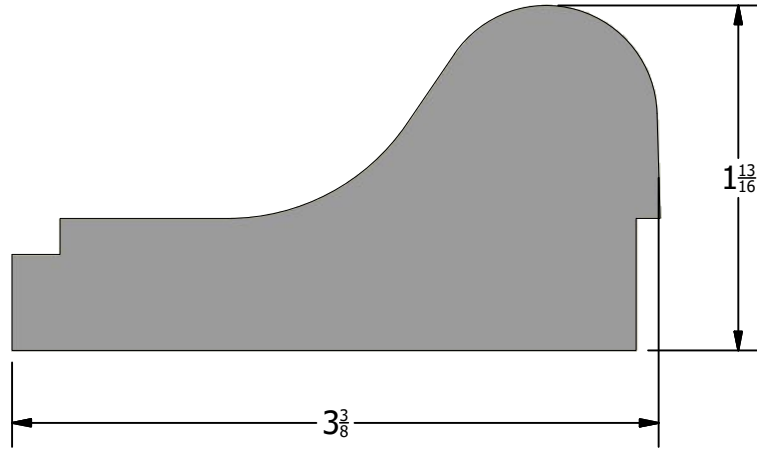

Description
Panel Mould

Part Number
Pan-55

-344-

Back

Scale 1 : 1



HOMESTEAD
WOODWORKS

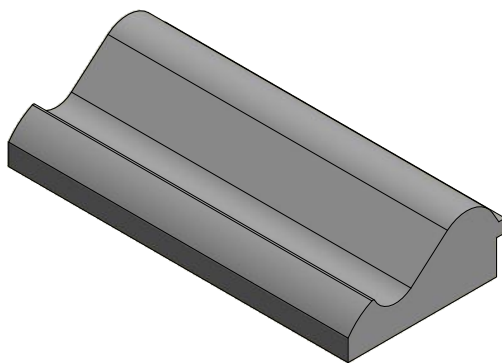
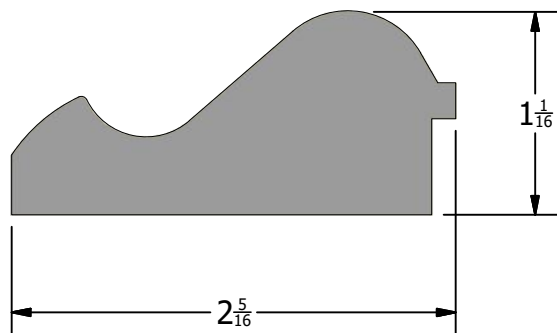

Description
Panel Mould

Part Number
Pan-56

-345-

Back

Scale 1 : 1



HOMESTEAD
WOODWORKS

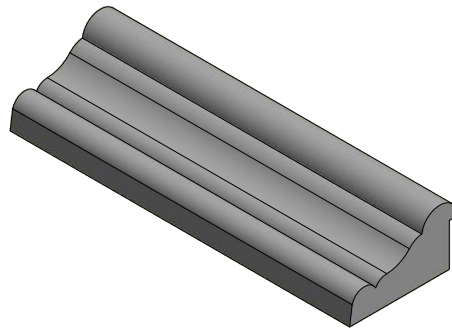
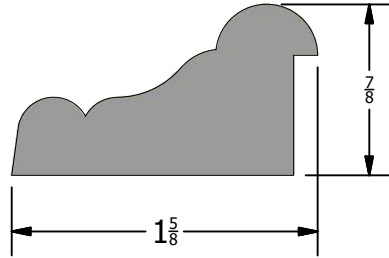

Description
Panel Mould

Part Number
Pan-57



-346-

Back

Scale 1 : 1

HOMESTEAD
WOODWORKS

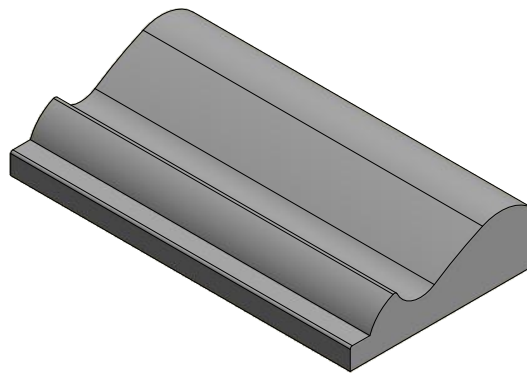
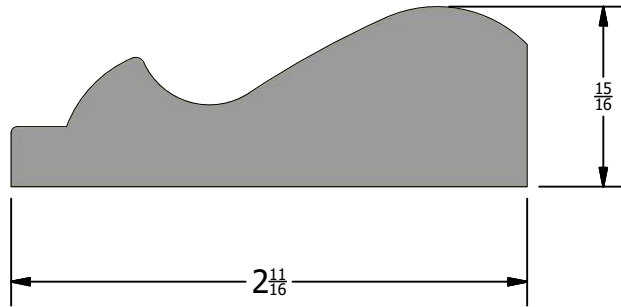

Description
Panel Mould

Part Number
Pan-58

-347-

Back

Scale 1 : 1



HOMESTEAD
WOODWORKS

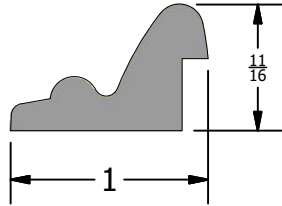

Description
Panel Mould

Part Number
Pan-59

-348-

Back

Scale 1 : 1



HOMESTEAD
WOODWORKS

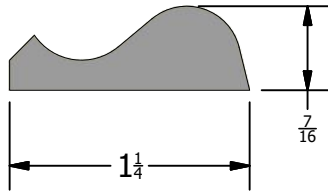

Description
Panel Mould

Part Number
Pan-60

-349-

Back

Scale 1 : 1



HOMESTEAD
WOODWORKS

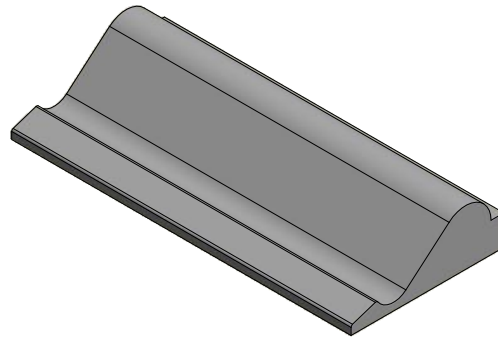
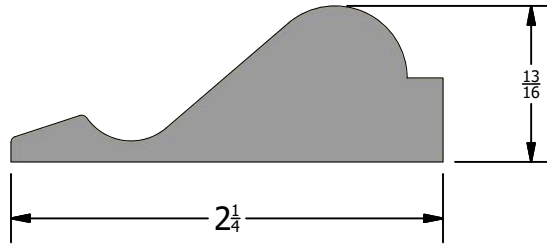

Description
Panel Mould

Part Number
Pan-61

-350-

Back

Scale 1 : 1

HOMESTEAD
WOODWORKS

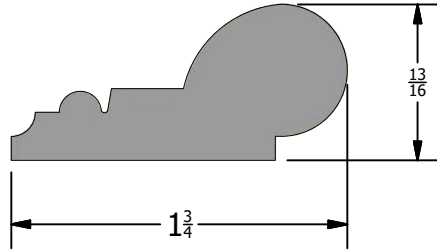

Description
Panel Mould

Part Number
Pan-62

-351-

Back

Scale 1 : 1



HOMESTEAD
WOODWORKS

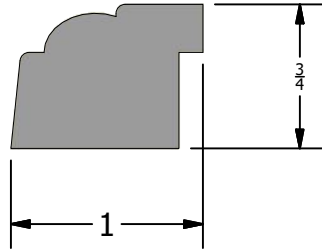

Description
Panel Mould

Part Number
Pan-63

-352-

Back

Scale 1 : 1



HOMESTEAD
WOODWORKS

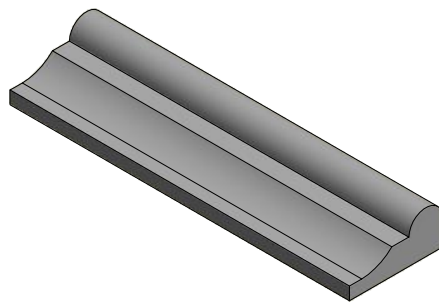
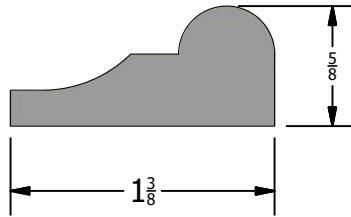

Description
Panel Mould

Part Number
Pan-64

-353-

Back

Scale 1 : 1



HOMESTEAD
WOODWORKS

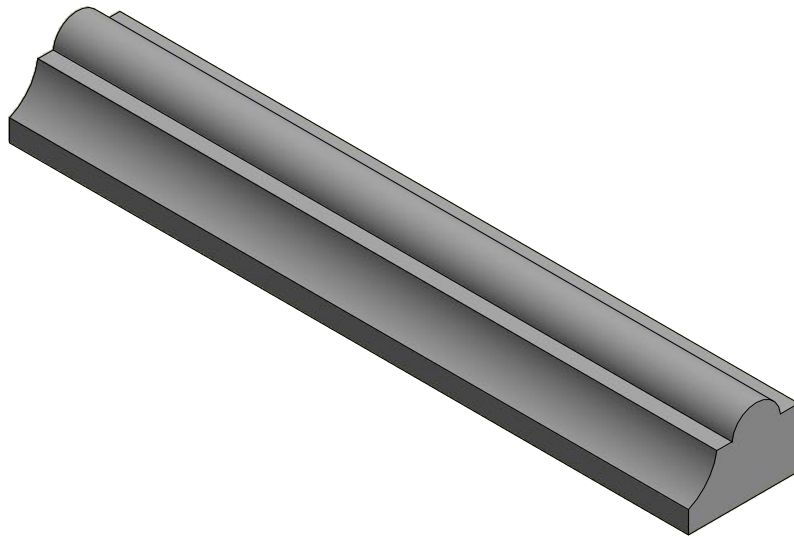
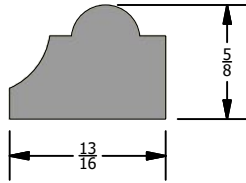

Description
Panel Mould

Part Number
Pan-65-A

-354-

Back

Scale 1 : 1



HOMESTEAD
WOODWORKS

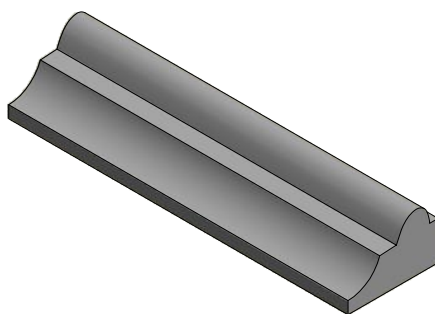
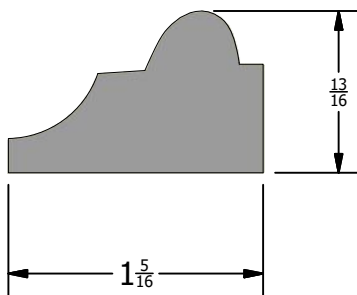

Description
Panel Mould

Part Number
Pan-65-B

-355-

Back

Scale 1 : 1

HOMESTEAD
WOODWORKS

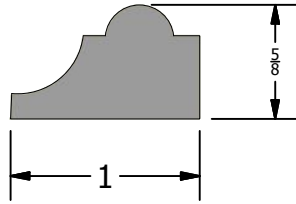

Description
Panel Mould

Part Number
Pan-65-C

-356-

Back

Scale 1 : 1



HOMESTEAD
WOODWORKS

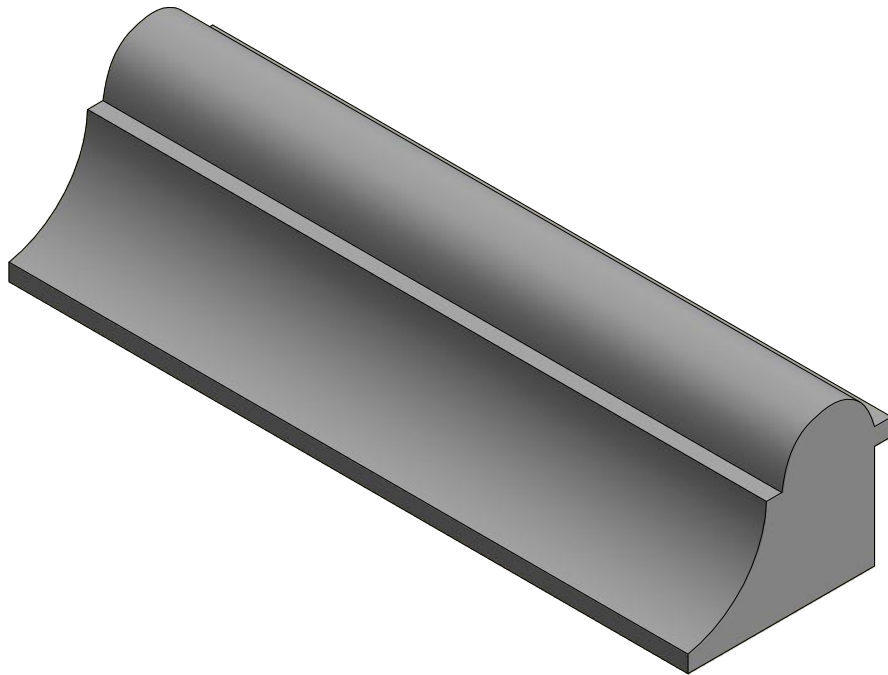
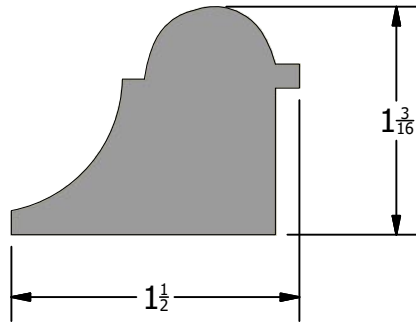

Description
Panel Mould

Part Number
Pan-66

-357-

Back

Scale 1 : 1



HOMESTEAD
WOODWORKS

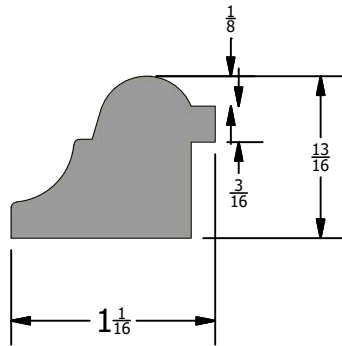

Description
Panel Mould

Part Number
Pan-66-B



-361-

Back

Scale 1



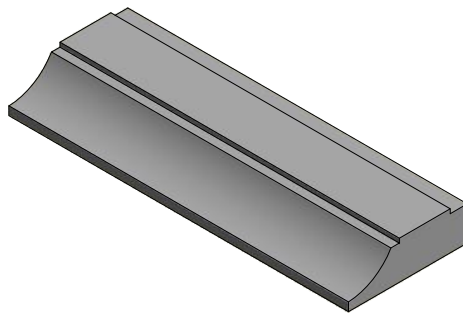
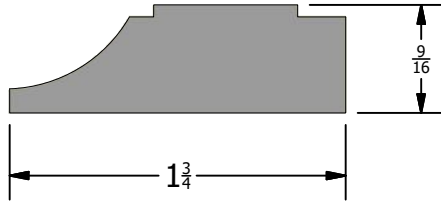

Description
Panel Mould

Part Number
Pan-67

-358-

Back

Scale 1 : 1

HOMESTEAD
WOODWORKS

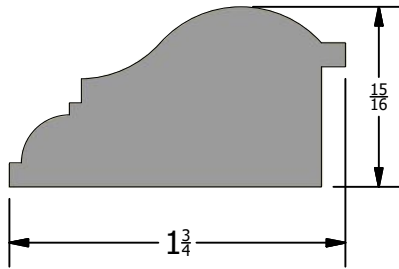

Description
Panel Mould

Part Number
Pan-68

-359-

Back

Scale 1 : 1



HOMESTEAD
WOODWORKS

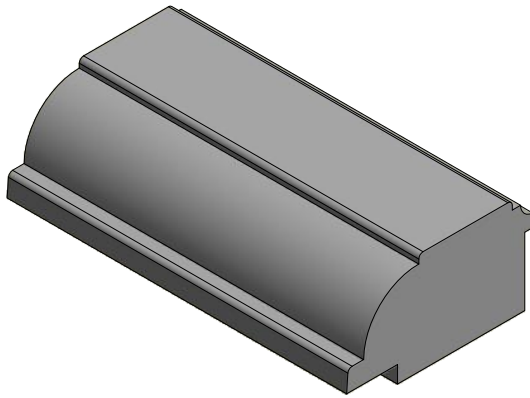
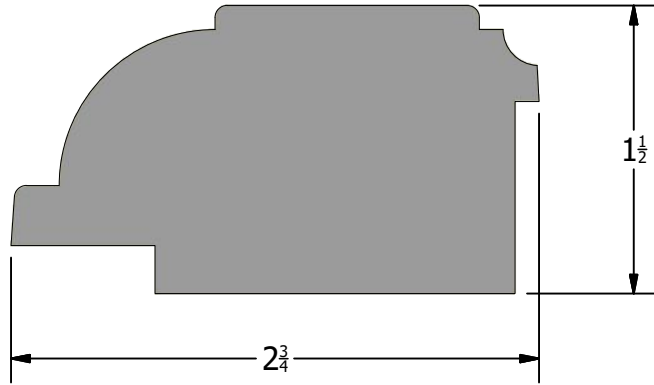

Description
Panel Mould

Part Number
Pan-69

-360-

Back

Scale 1 : 1

HOMESTEAD
WOODWORKS

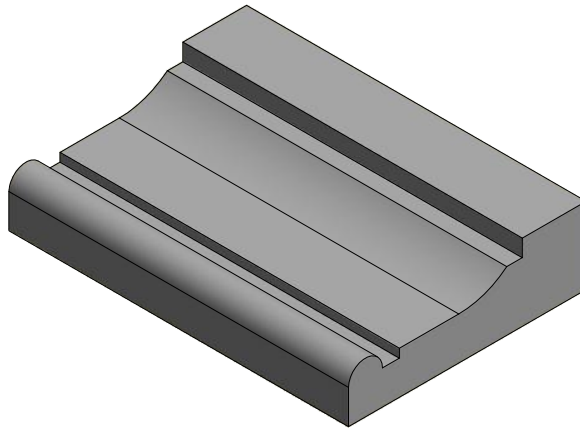
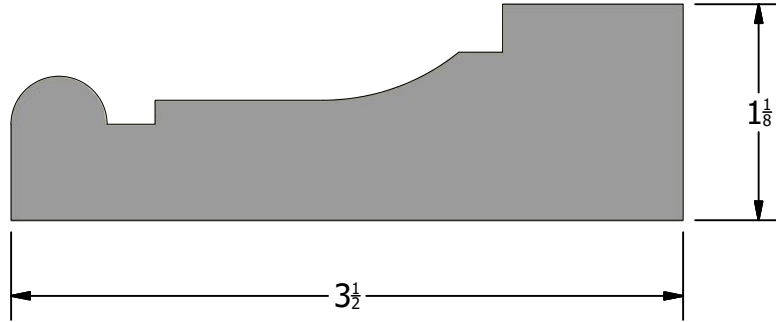

Description
Panel Mould

Part Number
Pan-70



-361-

Back

Scale 1 : 1

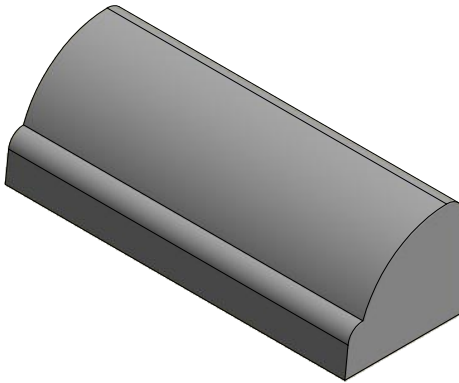
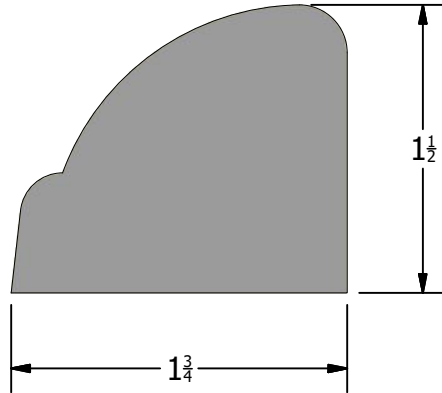

Description
Panel Mould

Part Number
Pan-71

-362-

Back

Scale 1 : 1



HOMESTEAD
WOODWORKS

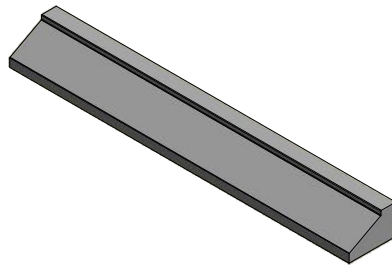
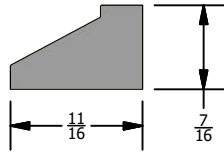

Description
Panel Mould

Part Number
Pan-72

-363-

Back

Scale 1 : 1



HOMESTEAD
WOODWORKS

Description

Part Number

-364-

Back

Scale



HOMESTEAD
WOODWORKS

Description

Part Number

-365-

Back

Scale



HOMESTEAD
WOODWORKS

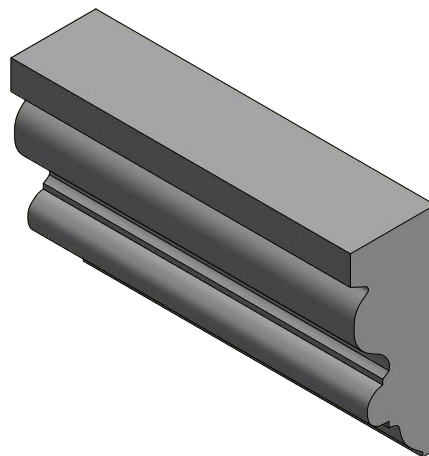
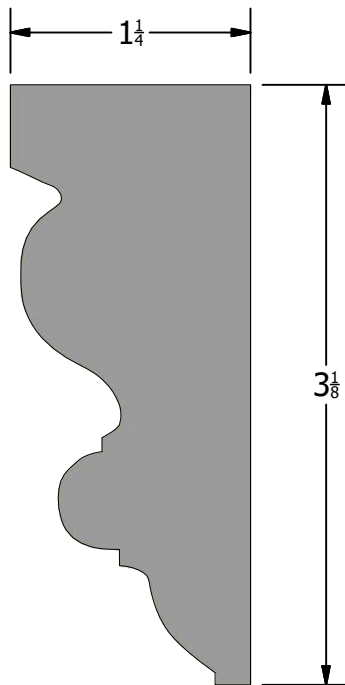

Description
Chair Rail

Part Number
Cha-01

-366-

Back

Scale 1 : 1



HOMESTEAD
WOODWORKS

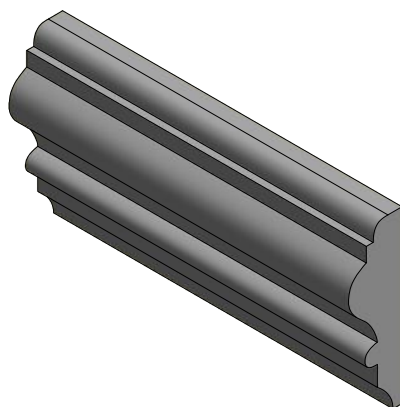
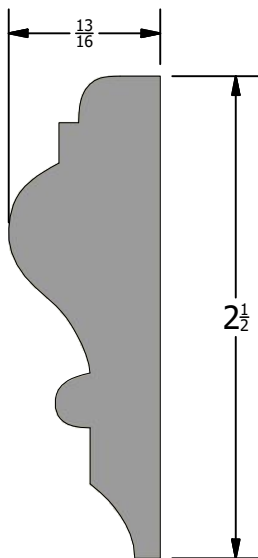

Description
Chair Rail

Part Number
Cha-02

-367-

Back

Scale 1 : 1



HOMESTEAD
WOODWORKS

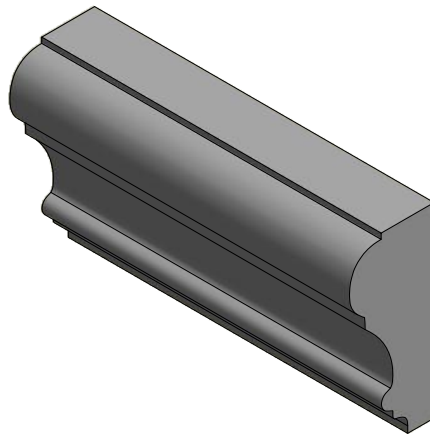
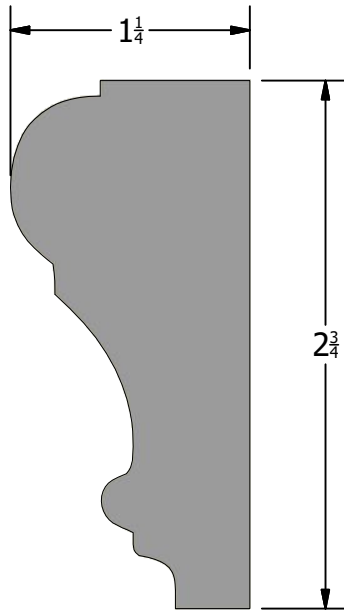

Description
Chair Rail

Part Number
Cha-03

-368-

Back

Scale 1 : 1



HOMESTEAD
WOODWORKS

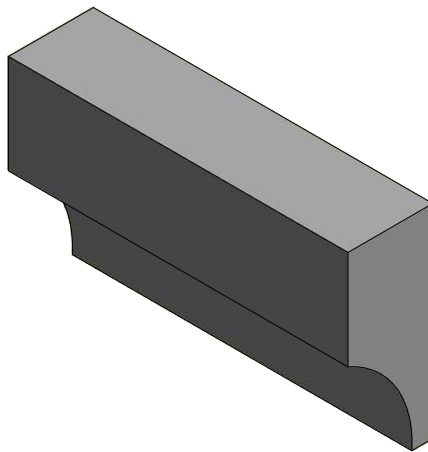
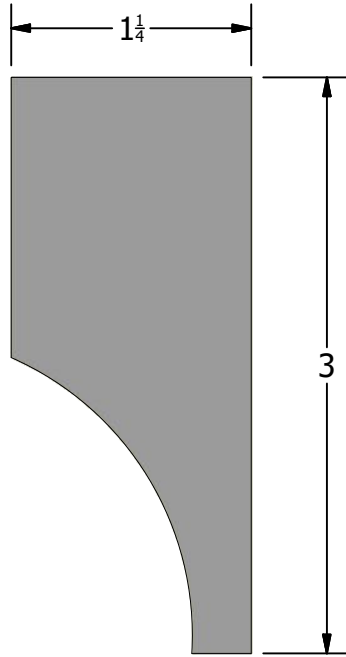

Description
Chair Rail

Part Number
Cha-04



-369-

Back

Scale 1 : 1

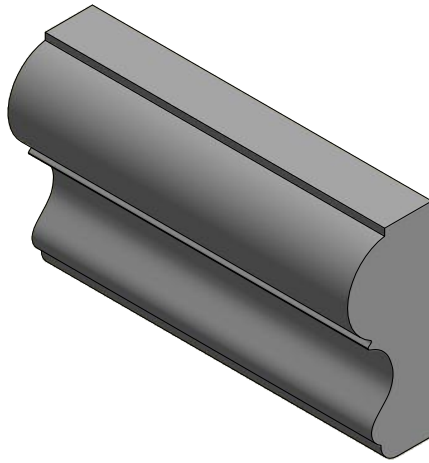
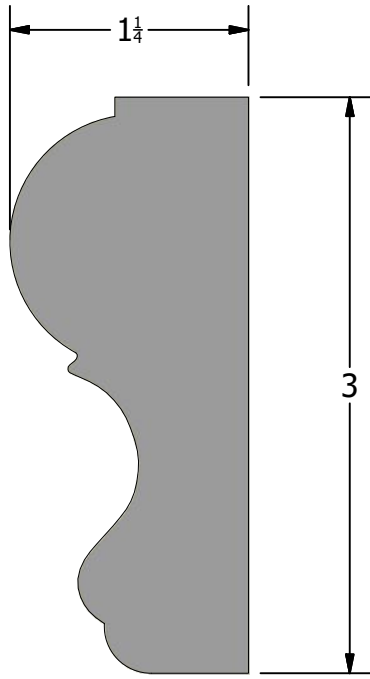

Description
Chair Rail

Part Number
Cha-05

-370-

Back

Scale 1 : 1



HOMESTEAD
WOODWORKS

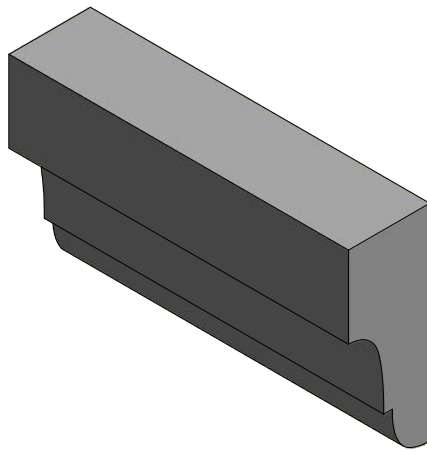
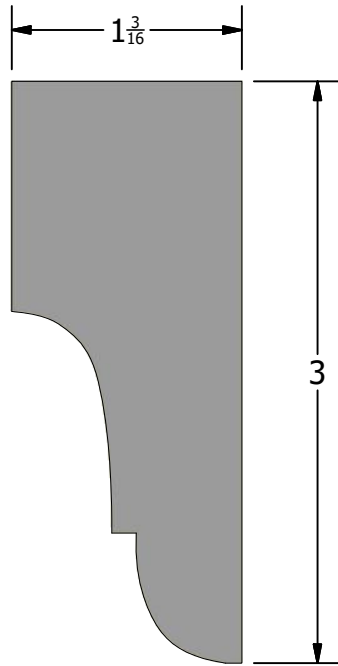

Description
Chair Rail

Part Number
Cha-06



-371-

Back

Scale 1 : 1

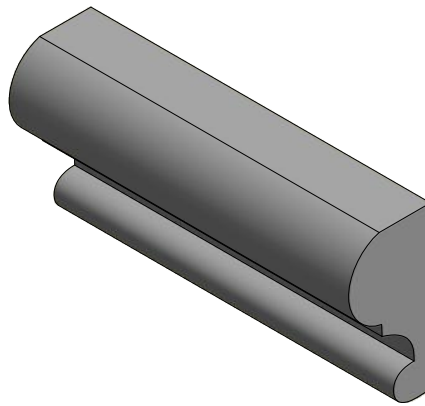
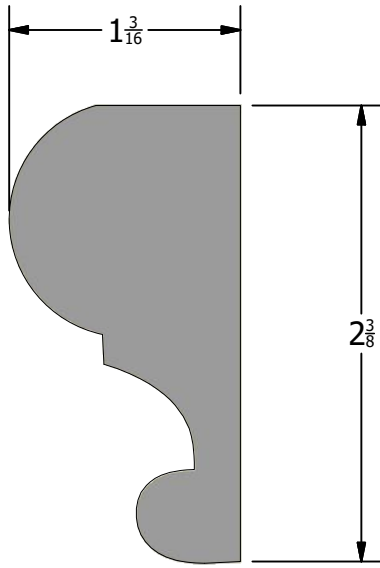

Description
Chair Rail

Part Number
Cha-07

-372-

Back

Scale 1 : 1



HOMESTEAD
WOODWORKS

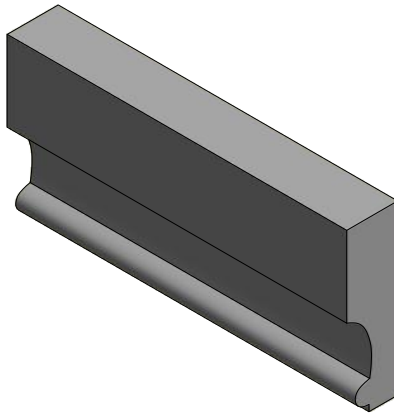
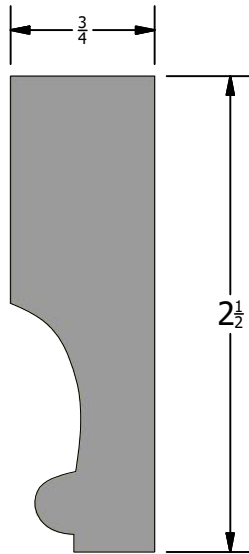

Description
Chair Rail

Part Number
Cha-08

-373-

Back

Scale 1 : 1



HOMESTEAD
WOODWORKS

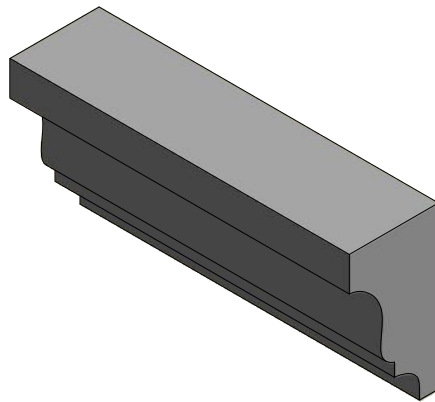
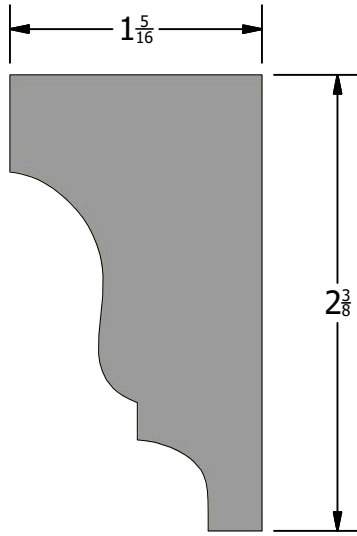

Description
Chair Rail

Part Number
Cha-09-A

-374-

Back

Scale 1 : 1

HOMESTEAD
WOODWORKS

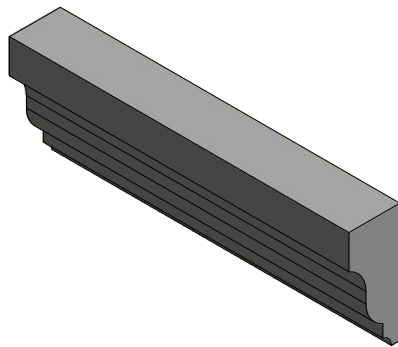
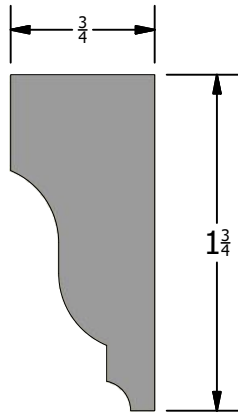

Description
Chair Rail

Part Number
Cha-9-B

-375-

Back

Scale 1 : 1

HOMESTEAD
WOODWORKS

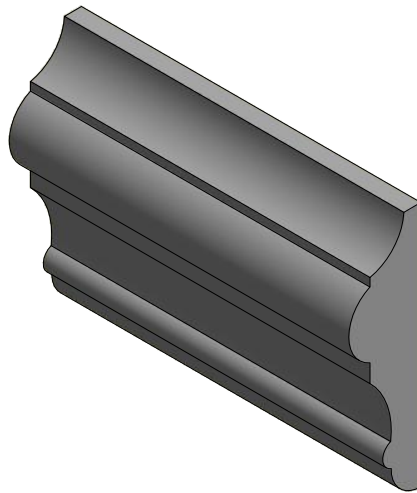
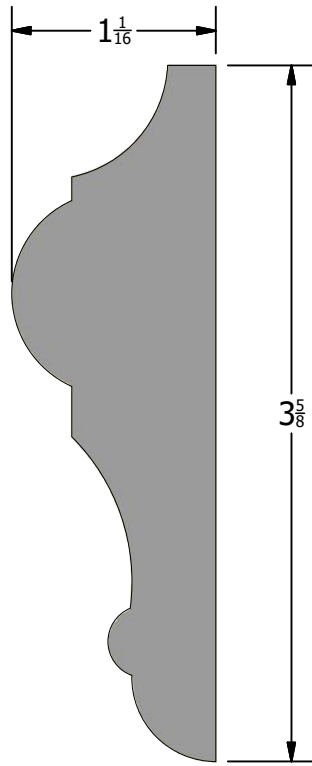

Description
Chair Rail

Part Number
Cha-10



-376-

Back

Scale 1 : 1

Description

Part Number

-377-

Back

Scale



HOMESTEAD
WOODWORKS

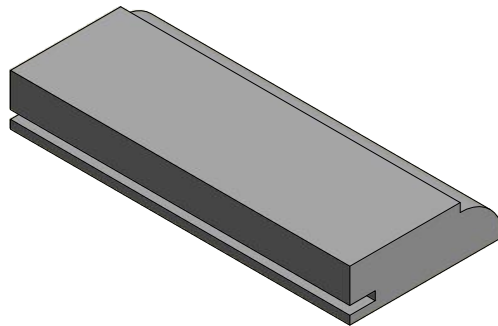
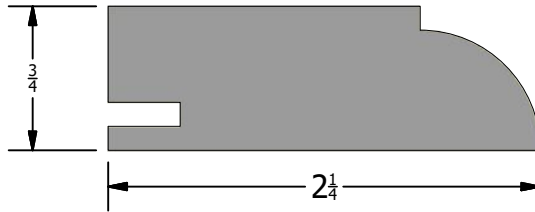

Description
Door Stop

Part Number
DS-E-01

-378-

Back

Scale 1 : 1



HOMESTEAD
WOODWORKS

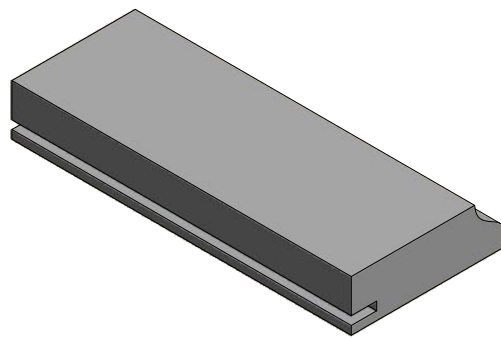
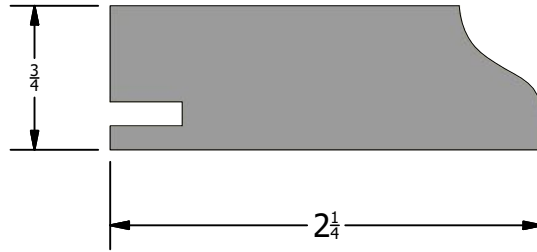

Description
Door Stop

Part Number
DS-E-02

-379-

Back

Scale 1 : 1



HOMESTEAD
WOODWORKS

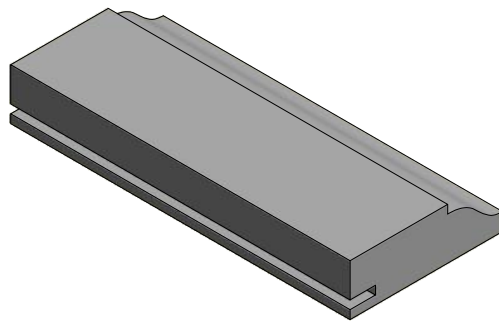
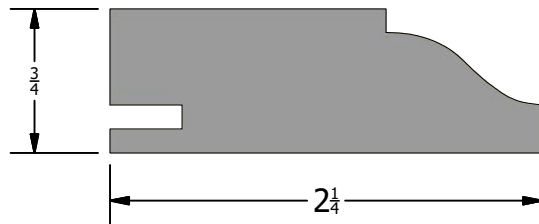

Description
Door Stop

Part Number
DS-E-03

-380-

Back

Scale 1 : 1



HOMESTEAD
WOODWORKS

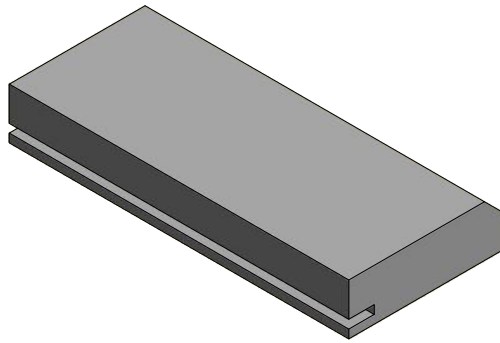
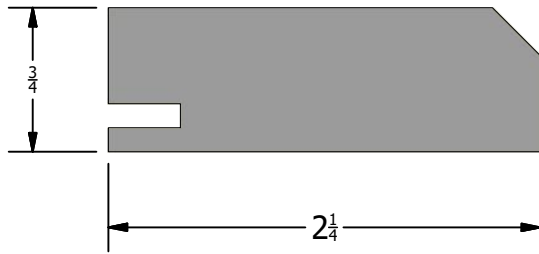

Description
Door Stop

Part Number
DS-E-04

-381-

Back

Scale 1 : 1



HOMESTEAD
WOODWORKS

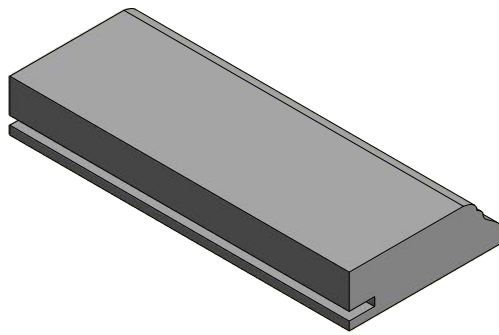
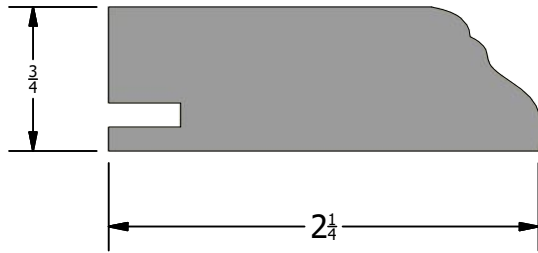

Description
Door Stop

Part Number
DS-E-05

-382-

Back

Scale 1 : 1



HOMESTEAD
WOODWORKS

Description

Part Number

-383-

Back



HOMESTEAD
WOODWORKS

Description

Part Number

-384-

Back

Scale



HOMESTEAD
WOODWORKS

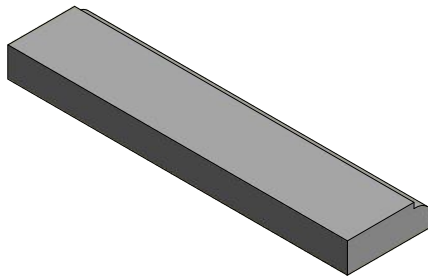
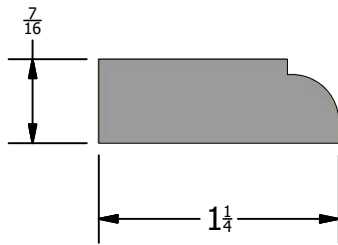

Description
Door Stop

Part Number
DS-I-01

-385-

Back

Scale 1 : 1



HOMESTEAD
WOODWORKS

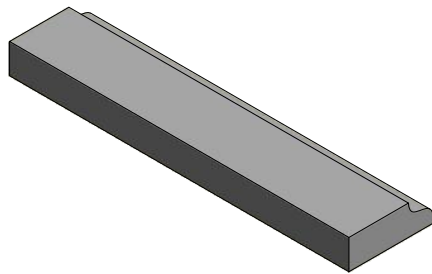
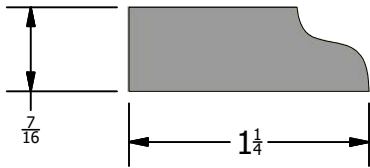

Description
Door Stop

Part Number
DS-I-02

-386-

Back

Scale 1 : 1



HOMESTEAD
WOODWORKS

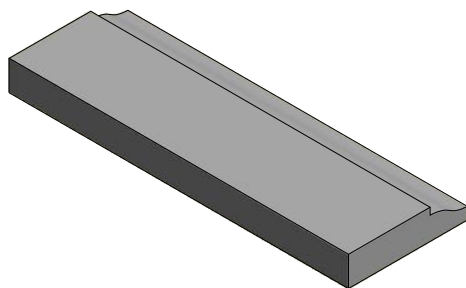
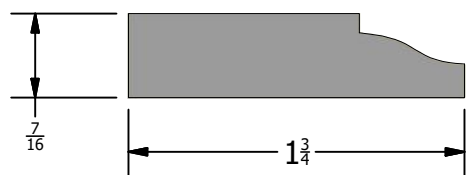

Description
Door Stop

Part Number
DS-I-03

-387-

Back

Scale 1 : 1

HOMESTEAD
WOODWORKS

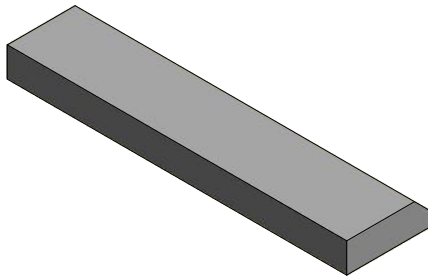
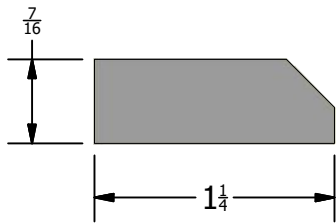

Description
Door Stop

Part Number
DS-I-04

-388-

Back

Scale 1 : 1



HOMESTEAD
WOODWORKS

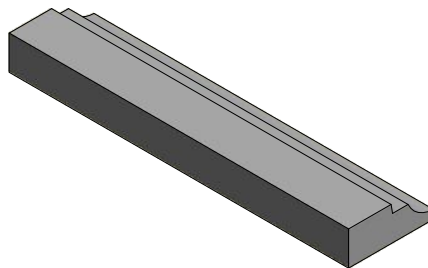
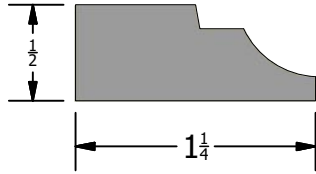

Description
Door Stop

Part Number
DS-I-05

-389-

Back

Scale 1 : 1



HOMESTEAD
WOODWORKS

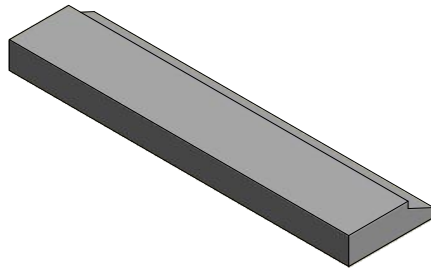
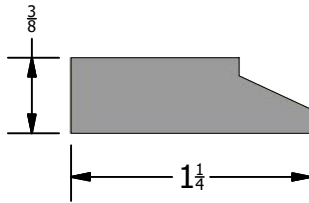

Description
Door Stop

Part Number
DS-I-06

-390-

Back

Scale 1 : 1



HOMESTEAD
WOODWORKS

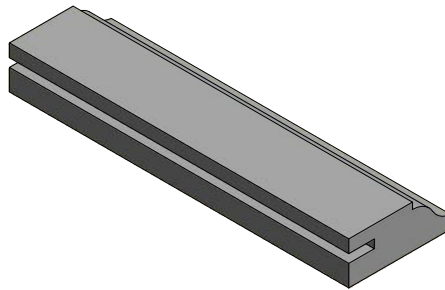
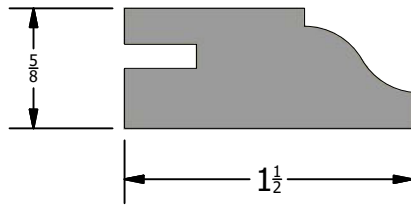

Description
Door Stop

Part Number
DS-I-07

-391-

Back

Scale



HOMESTEAD
WOODWORKS

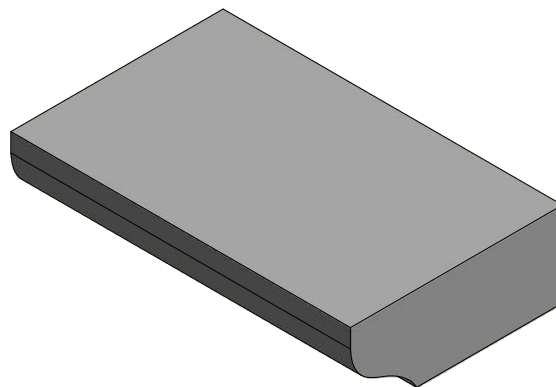
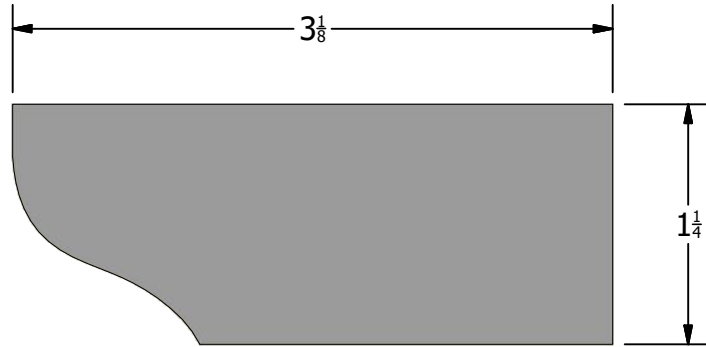

Description Window Sill		Part Number Sill-01	 HOMESTEAD WOODWORKS
-392-	Back	Scale 1 : 1	

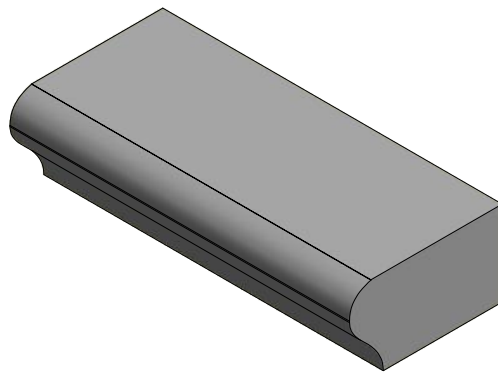
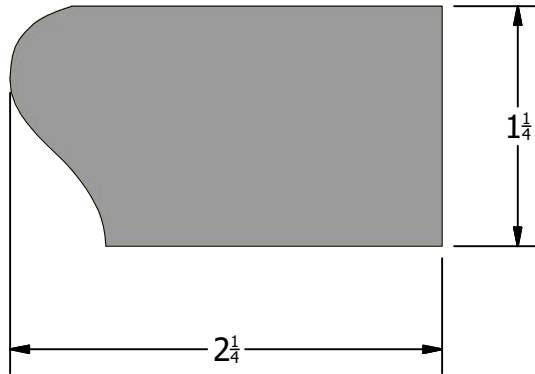

Description
Window Sill

Part Number
Sill-02

-393-

Back

Scale 1 : 1



HOMESTEAD
WOODWORKS

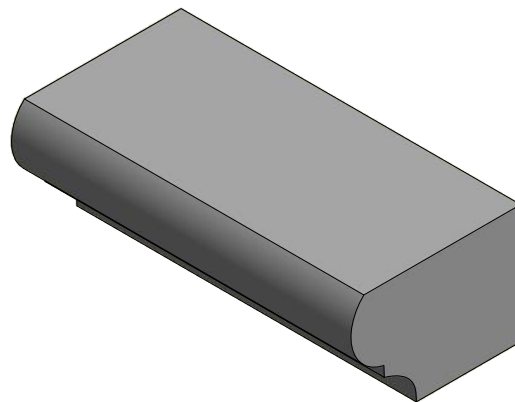
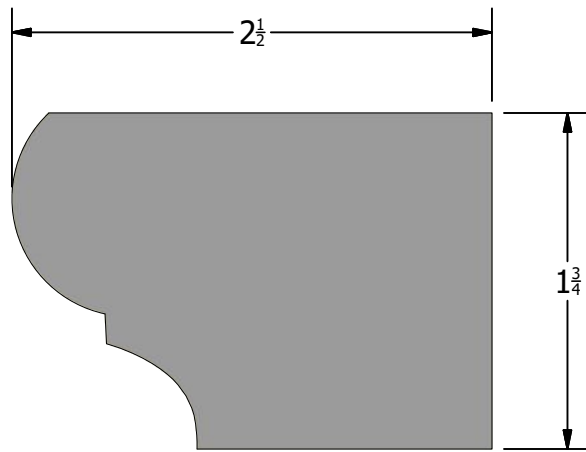

Description
Window Sill

Part Number
Sill-03

-394-

Back

Scale 1 : 1



HOMESTEAD
WOODWORKS

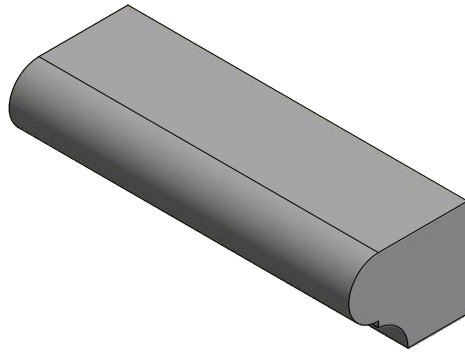
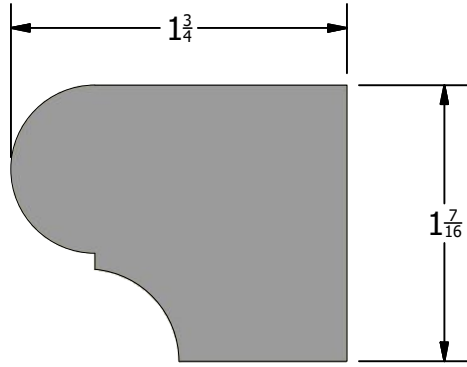

Description
Window Sill

Part Number
Sill-04



-395-

Back

Scale 1 : 1

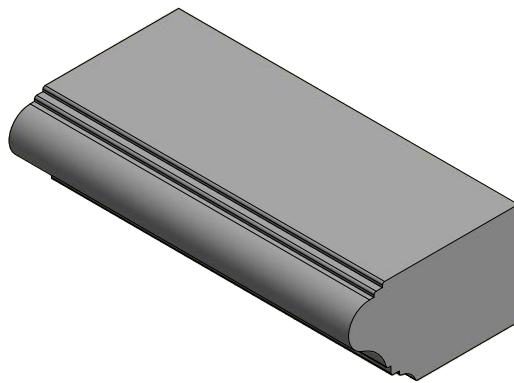
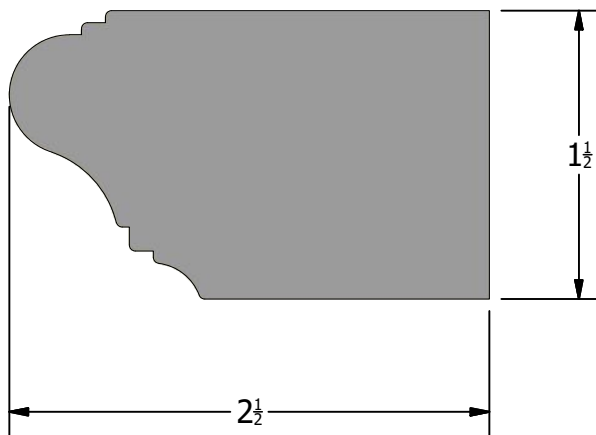

Description
Window Sill

Part Number
Sill-05

-396-

Back

Scale 1 : 1



HOMESTEAD
WOODWORKS

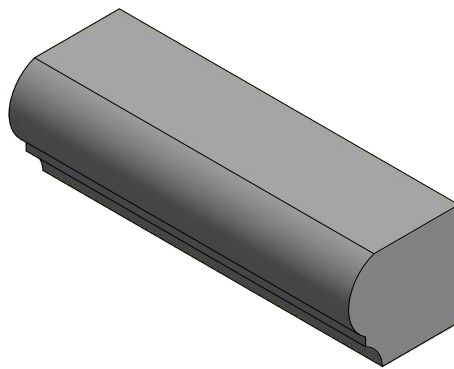
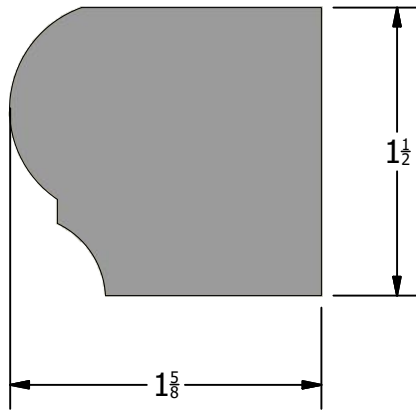

Description
Window Sill

Part Number
Sill-06

-397-

Back

Scale 1 : 1



HOMESTEAD
WOODWORKS

Description

Part Number

-398-

Back

Scale



HOMESTEAD
WOODWORKS

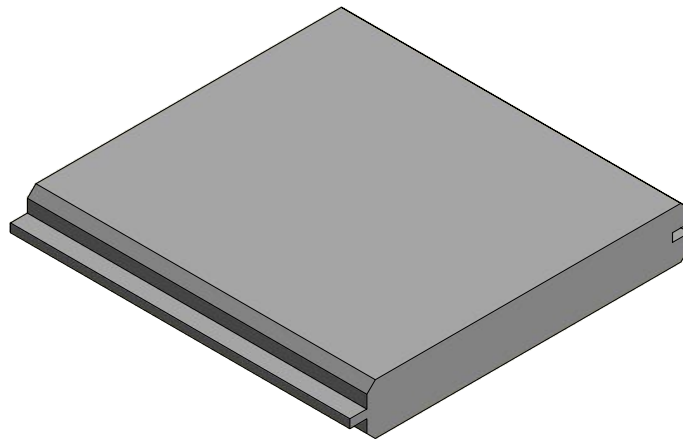
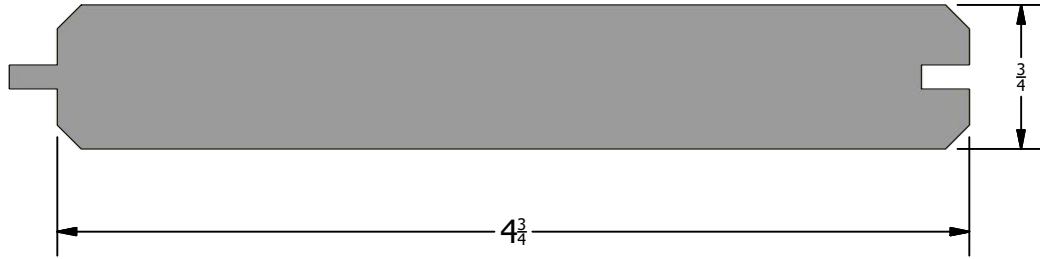

Description T & G Paneling		Part Number T G-01	 HOMESTEAD WOODWORKS
-399-	Back	Scale 1 : 1	

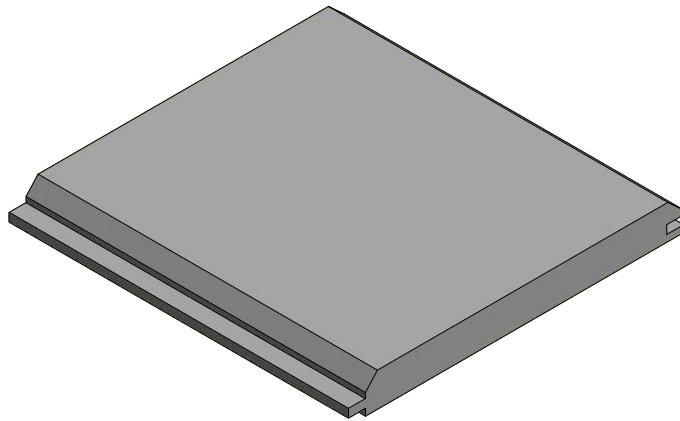
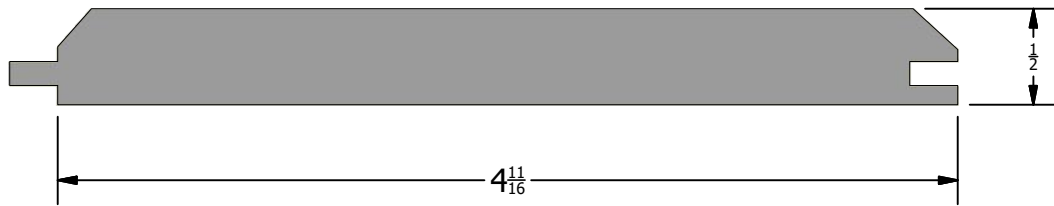

Description
T & G Paneling

Part Number
TG-02

-400-

Back

Scale 1 : 1



HOMESTEAD
WOODWORKS

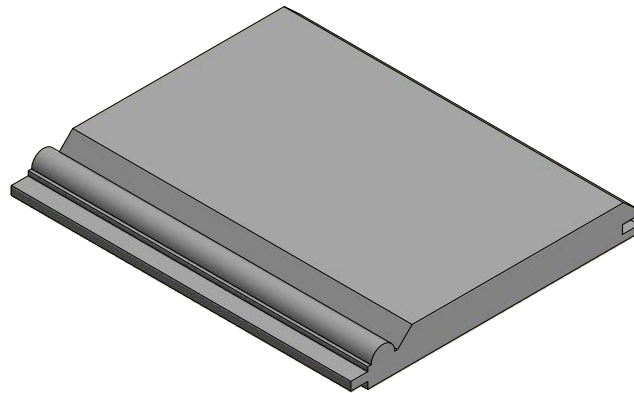
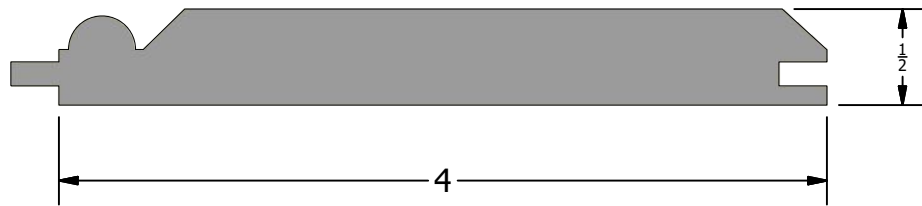

Description
T & G Paneling

Part Number
TG-03

-401-

Back

Scale 1 : 1



HOMESTEAD
WOODWORKS

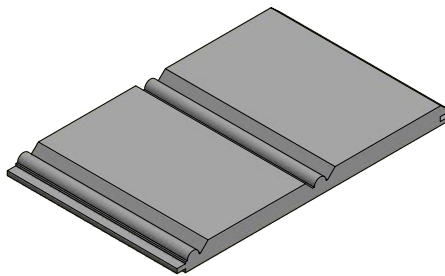
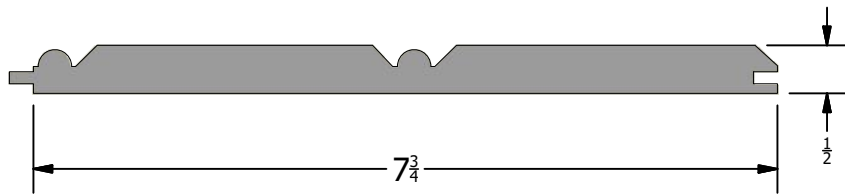

Description
T & G Paneling

Part Number
TG-04

-402-

Back

Scale 1 / 2



HOMESTEAD
WOODWORKS

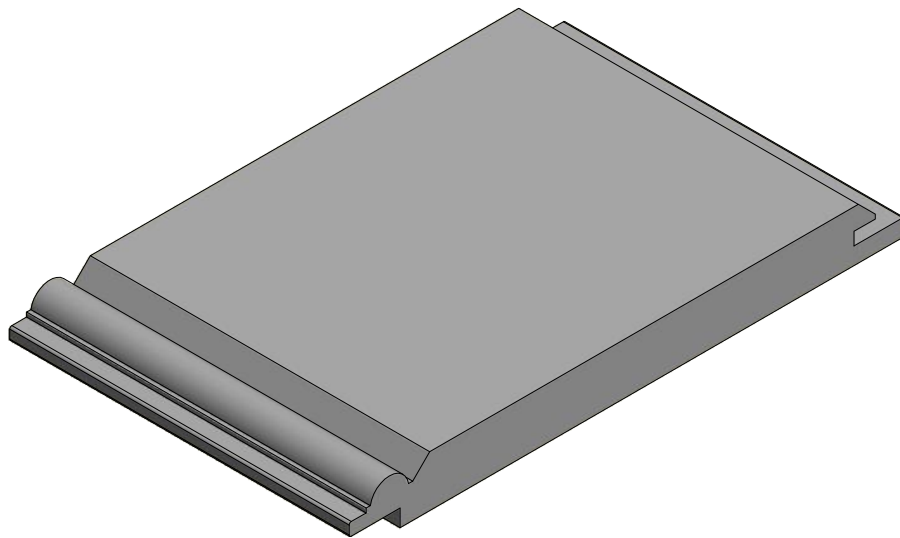
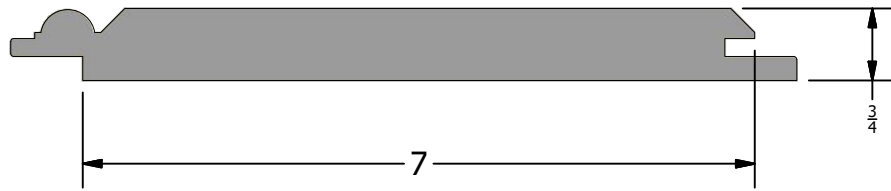

Description T & G Paneling		Part Number TG-05	 HOMESTEAD WOODWORKS
-403-	Back	Scale 1 / 2	

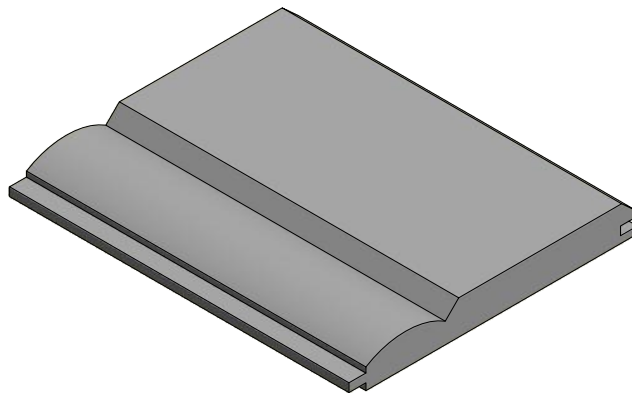
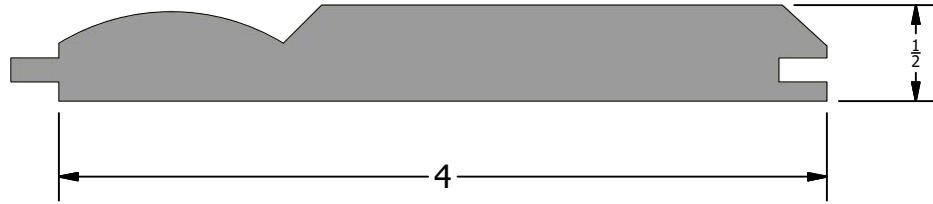

Description
T & G Paneling

Part Number
TG-06

-404-

Back

Scale 1 : 1

HOMESTEAD
WOODWORKS

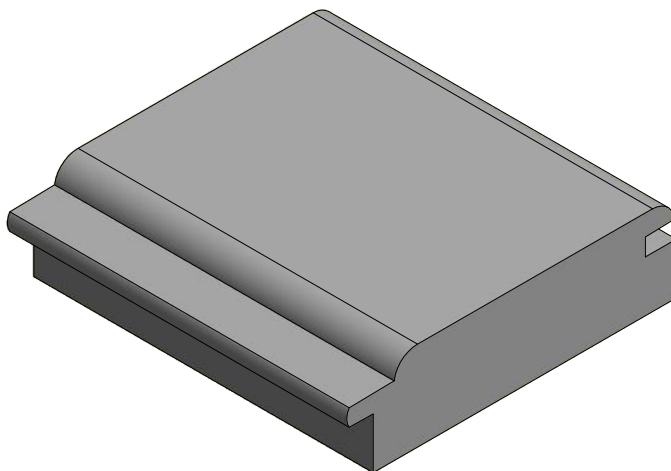
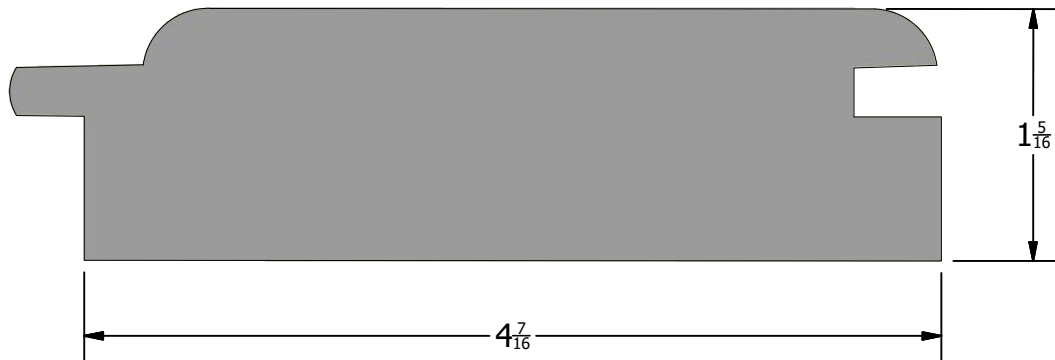

Description T & G Paneling		Part Number TG-07	 HOMESTEAD WOODWORKS
-405-	Back	Scale 1 : 1	

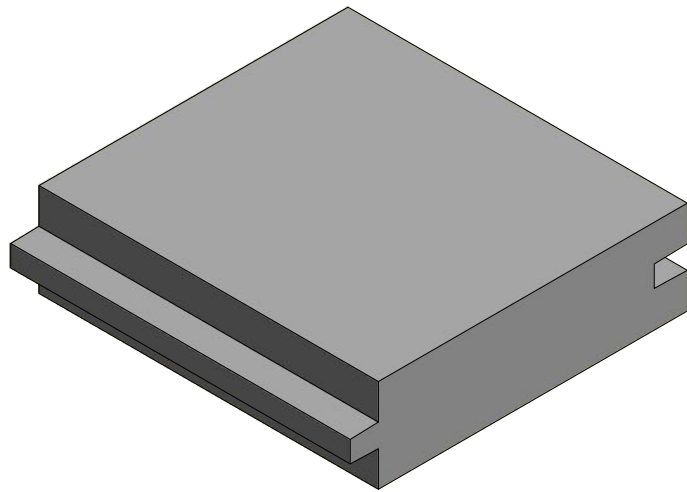
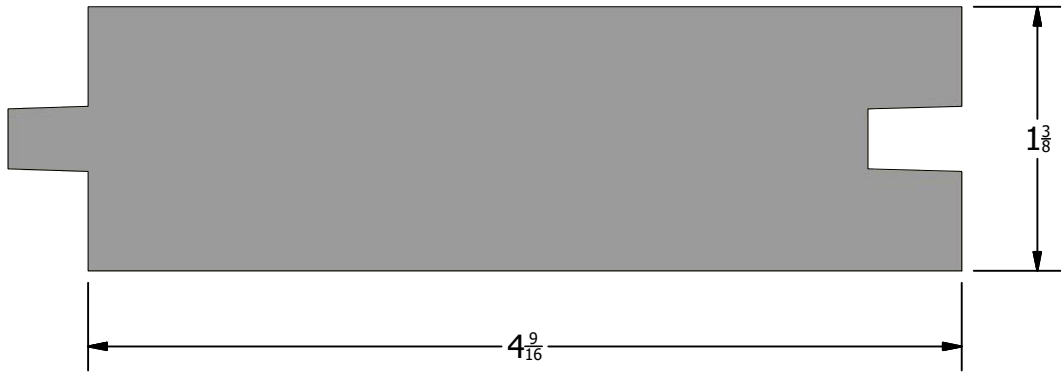

Description
T & G Paneling

Part Number
TG-08



-406-

Back

Scale 1 : 1

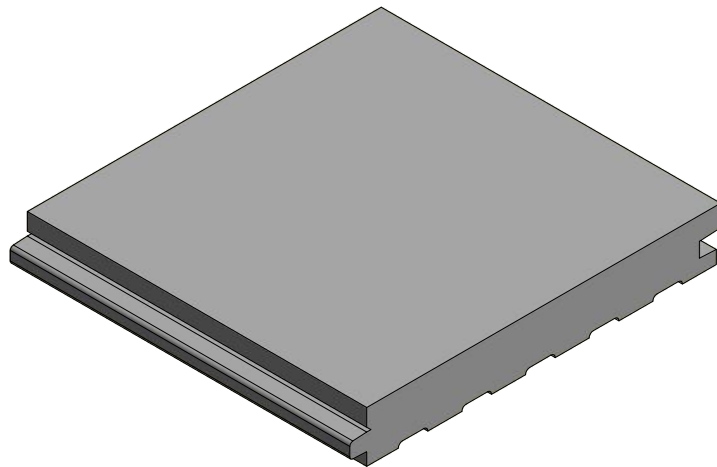
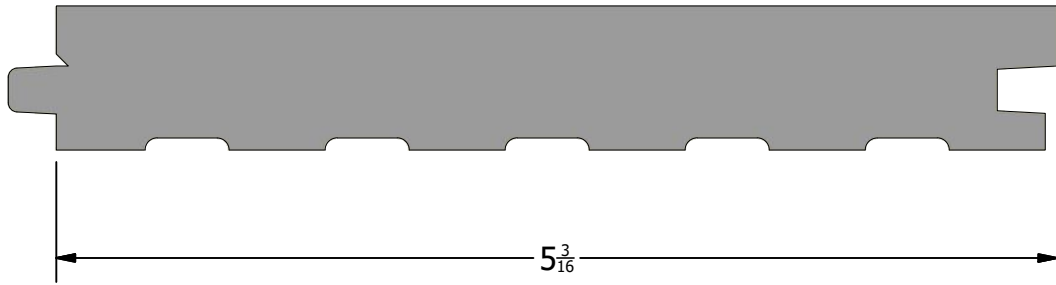

Description
T & G Paneling

Part Number
TG-09-A

-407-

Back

Scale 1 : 1



HOMESTEAD
WOODWORKS

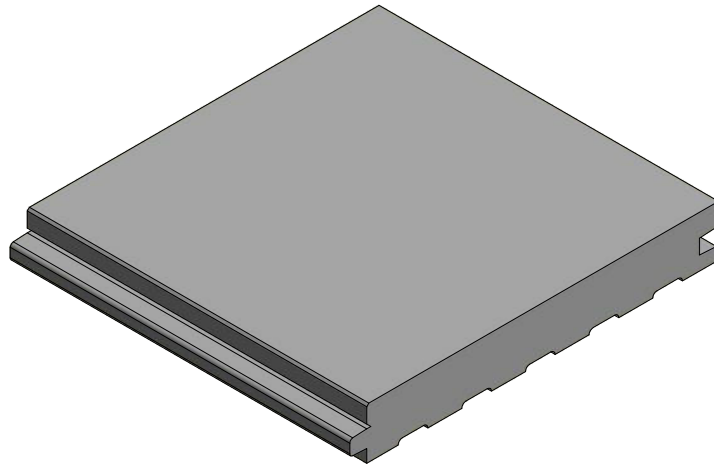
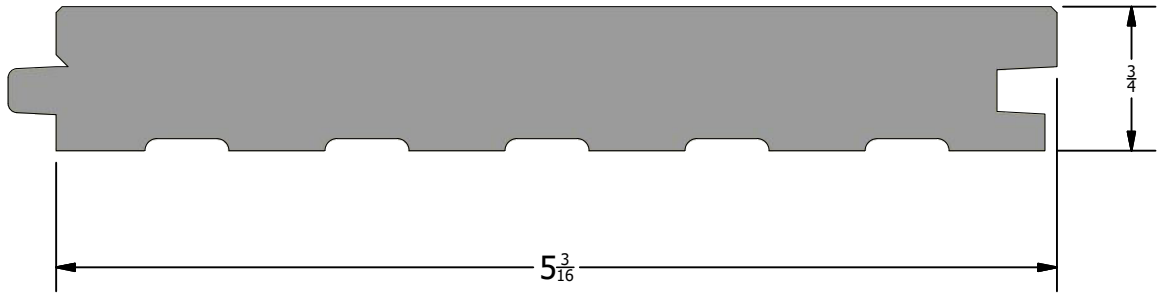

Description T & G with Micro Bevel		Part Number TG-09-B	 HOMESTEAD WOODWORKS
-412-	Back	Scale 1	

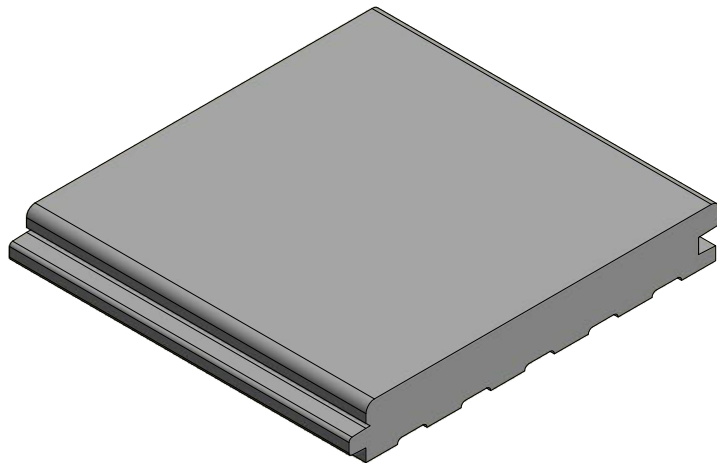
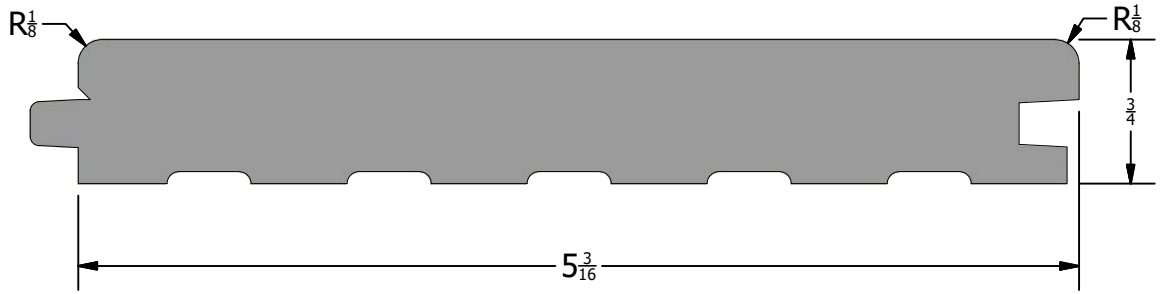

Description
T & G 1/8 R

Part Number
TG-09-C

-413-

Back

Scale 1



HOMESTEAD
WOODWORKS

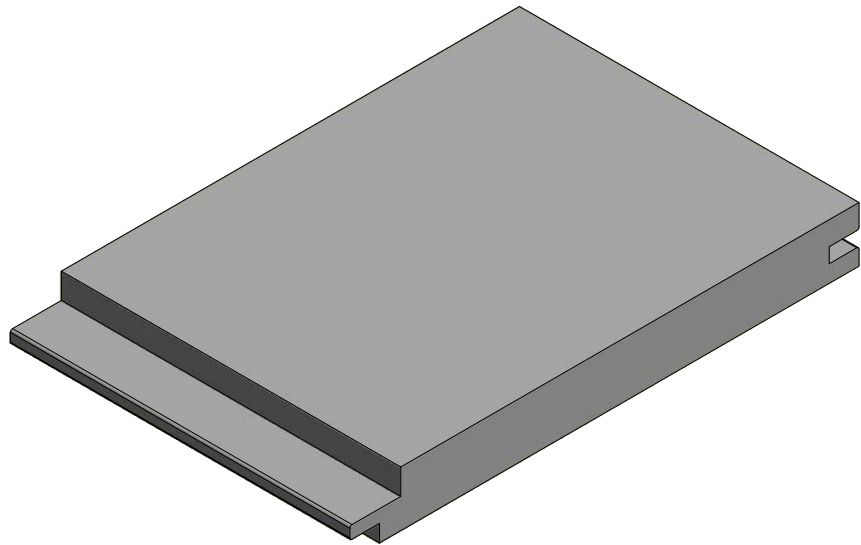
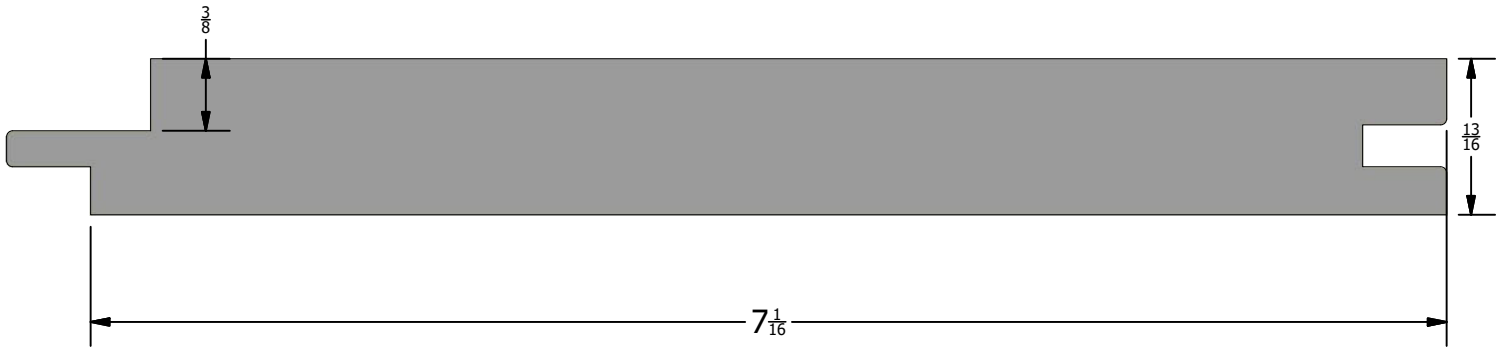

Description T & G Paneling		Part Number TG-10	 HOMESTEAD WOODWORKS
-414-	Back	Scale 1	

Description

Part Number

-408-

Back

Scale



HOMESTEAD
WOODWORKS

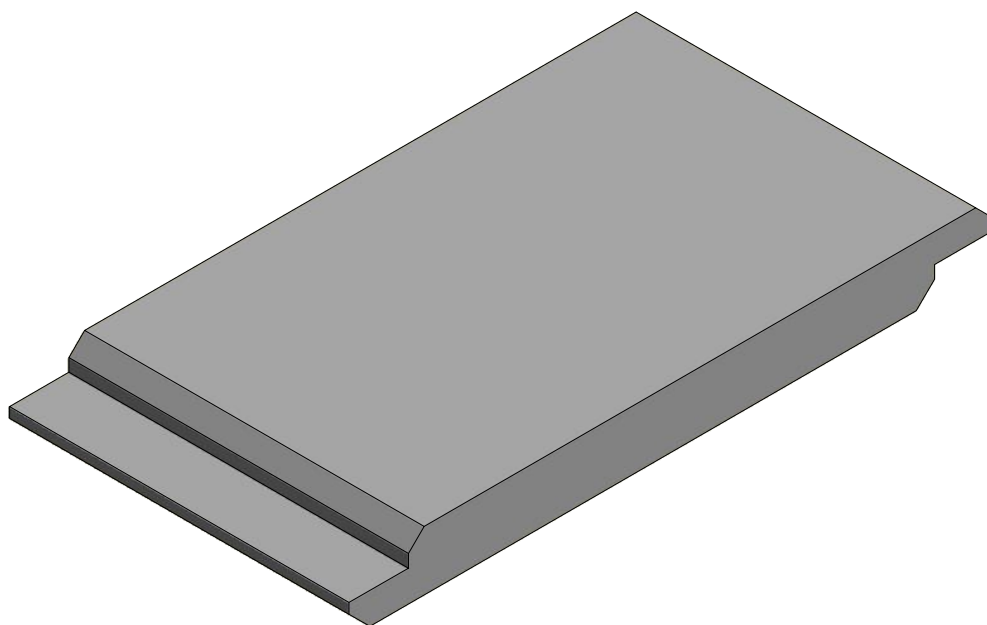
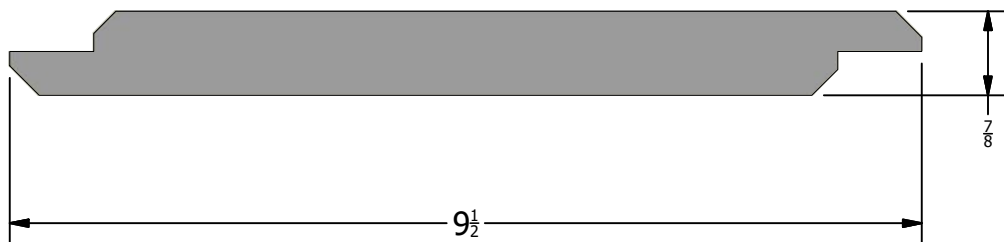

Description
Shiplap

Part Number
SHL-01



-409-

Back

Scale 1 / 2

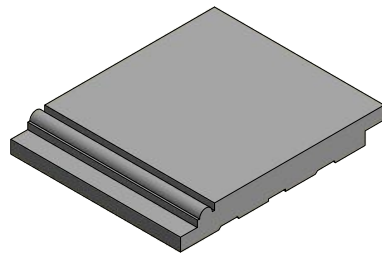
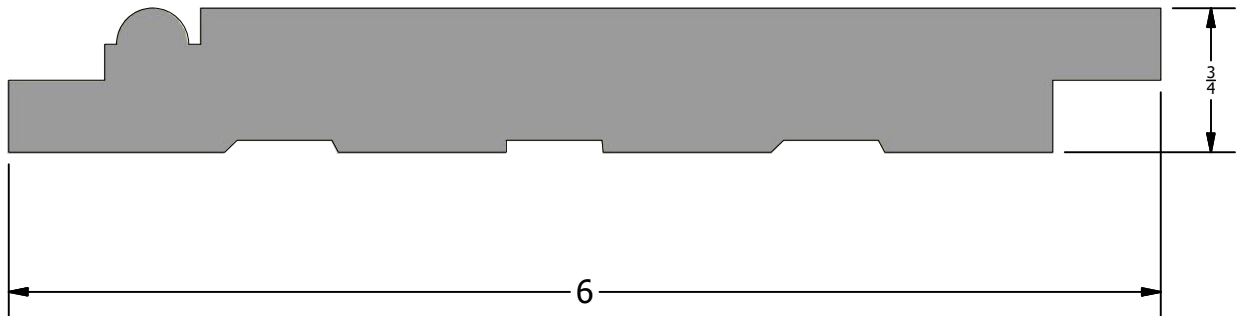

Description
Shiplap

Part Number
SHL-02



-410-

Back

Scale 1 : 1

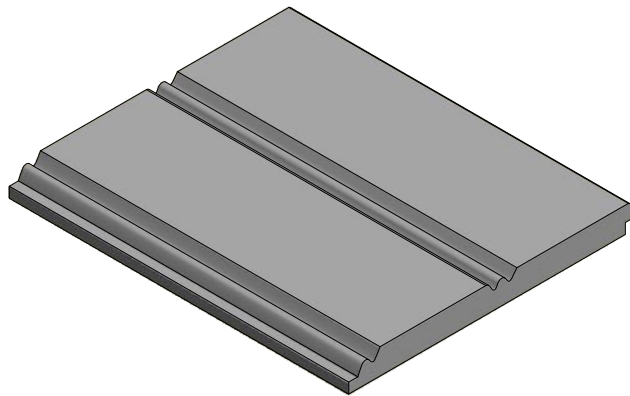
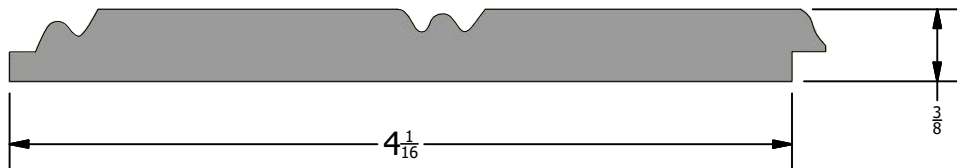

Description
Shiplap

Part Number
SHL-03



-411-

Back

Scale 1 : 1

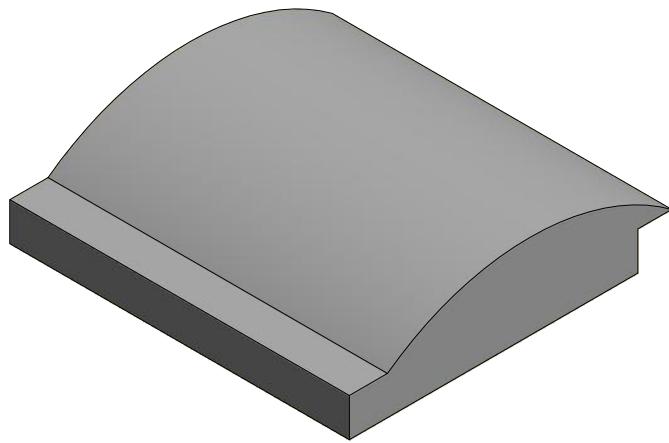
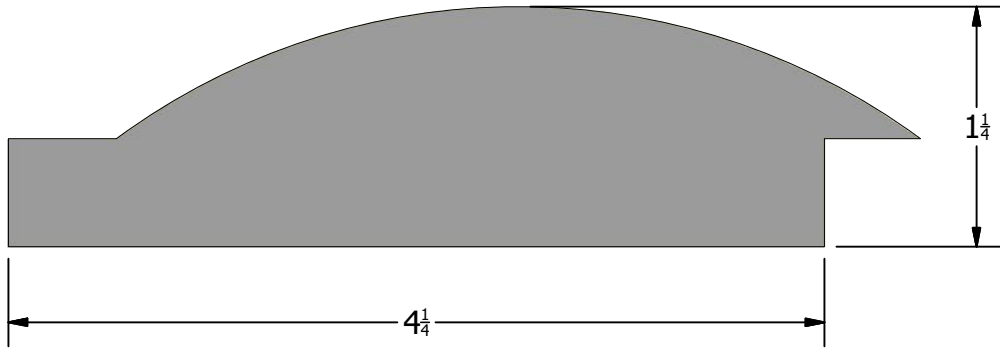

Description
Shiplap

Part Number
SHL-04



-412-

Back

Scale 1 : 1

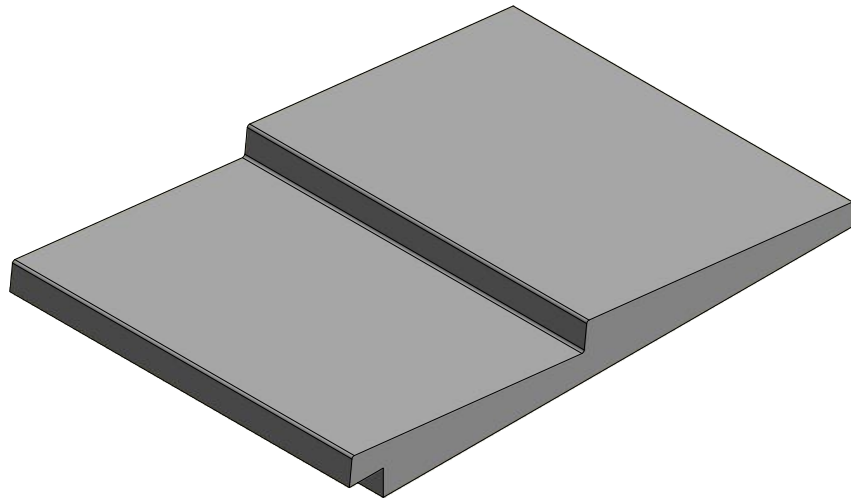
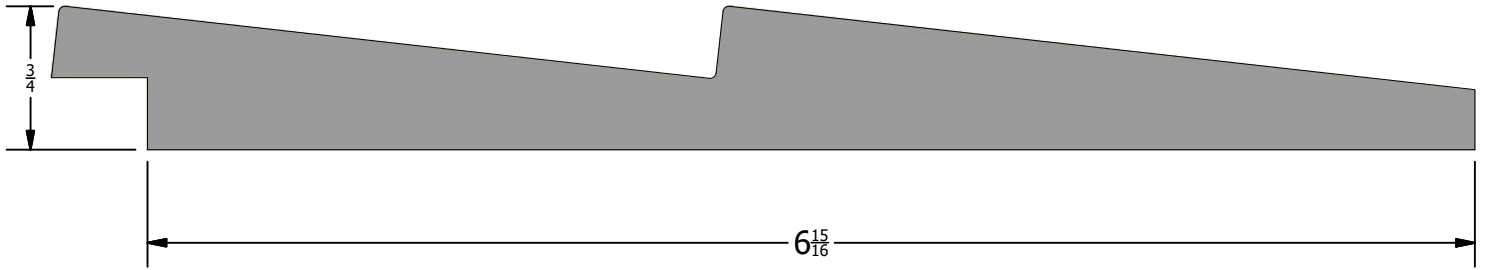

Description
Shiplap

Part Number
SHL-05

-413-

Back

Scale 1 : 1

HOMESTEAD
WOODWORKS

Description

Part Number

-414-

Back

Scale



HOMESTEAD
WOODWORKS

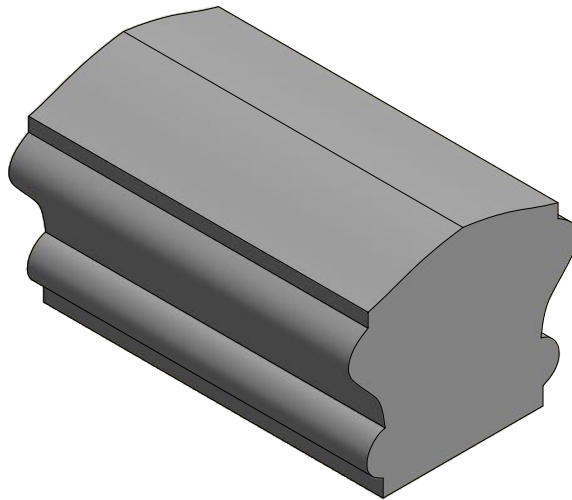
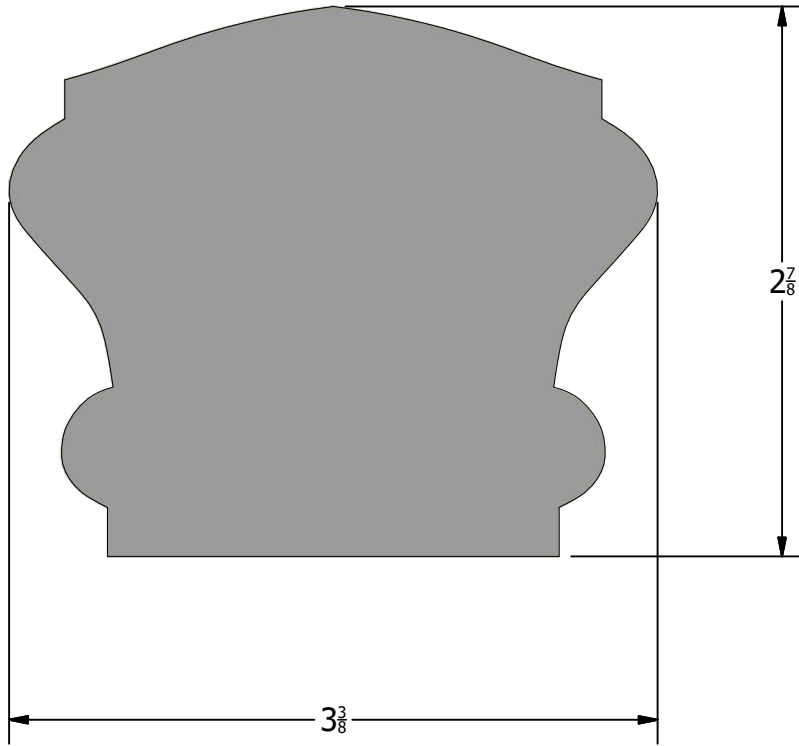

Description Hand Rail		Part Number HR-01	 HOMESTEAD WOODWORKS
-415-	Back	Scale 1 : 1	

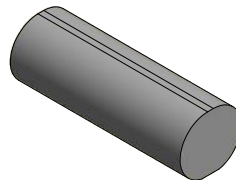
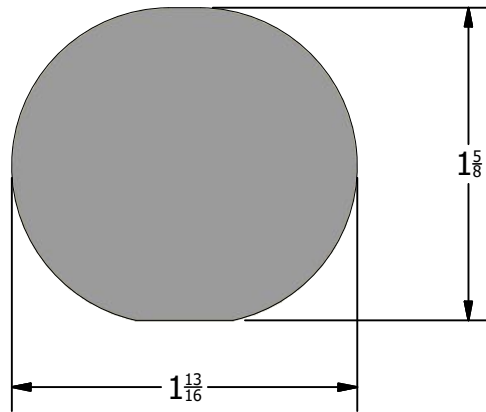

Description
Hand Rail

Part Number
HR-02

-416-

Back

Scale 1 : 1



HOMESTEAD
WOODWORKS

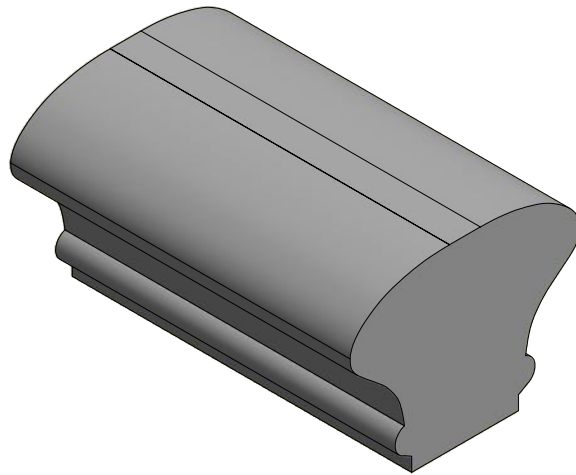
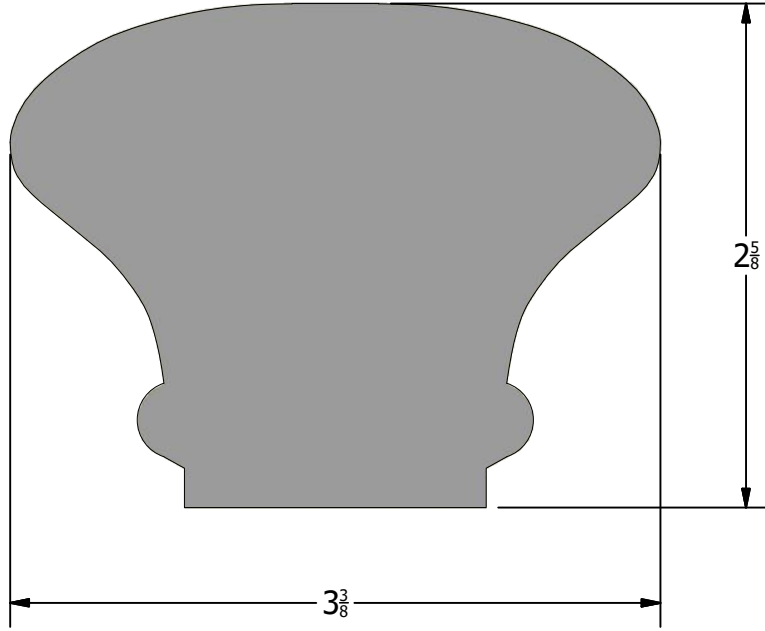

Description Hand Rail		Part Number HR-03	 HOMESTEAD WOODWORKS
-417-	Back	Scale 1 : 1	

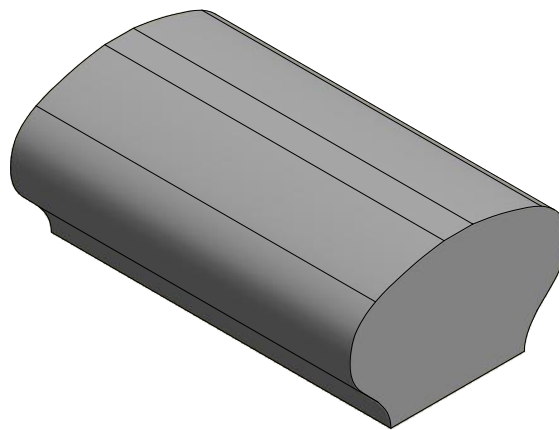
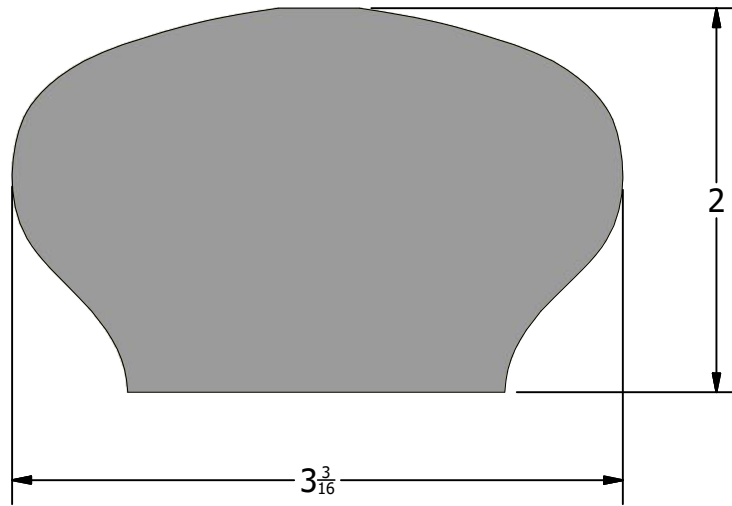

Description Hand Rail		Part Number HR-04	 HOMESTEAD WOODWORKS
-418-	Back	Scale 1 : 1	

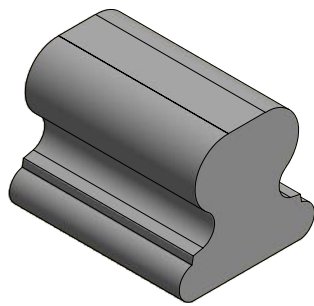
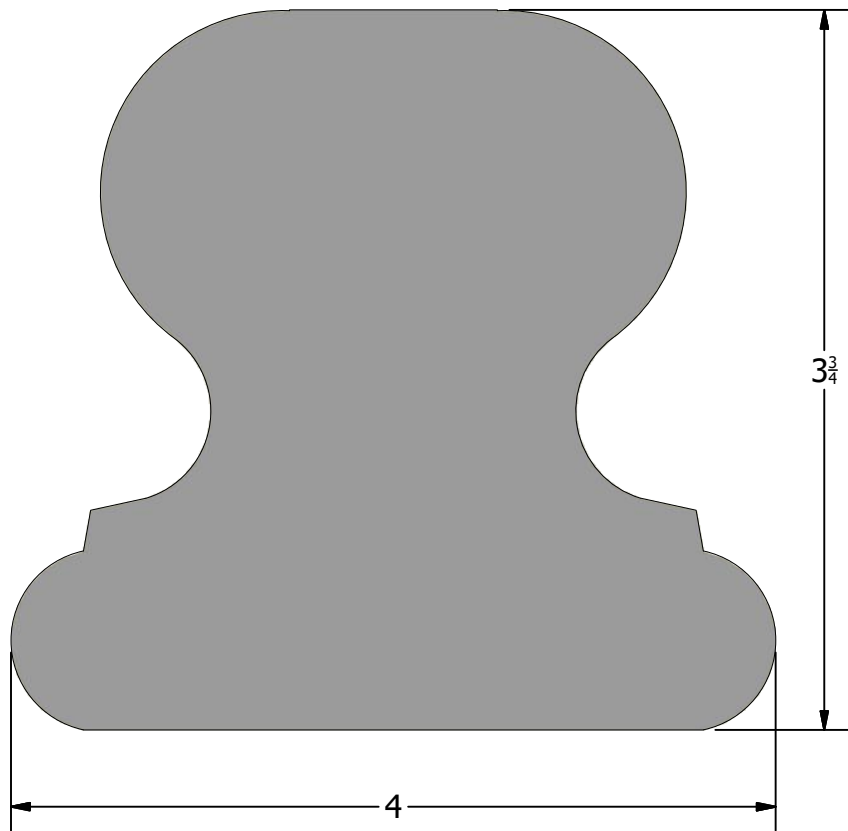

Description Hand Rail		Part Number HR-05	 HOMESTEAD WOODWORKS
-419-	Back	Scale 1 : 1	

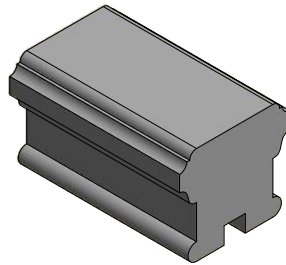
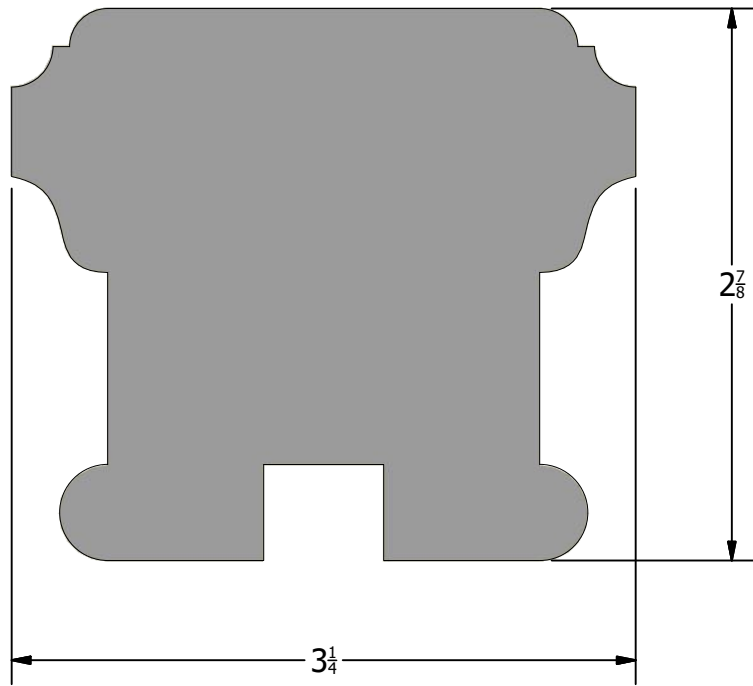

Description Hand Rail		Part Number HR-06	 HOMESTEAD WOODWORKS
-420-	Back	Scale 1 : 1	

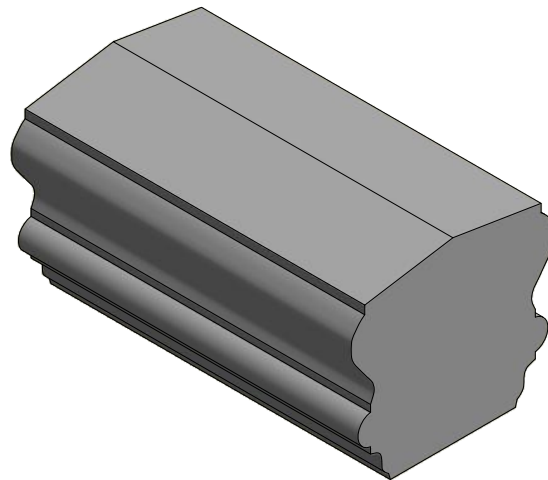
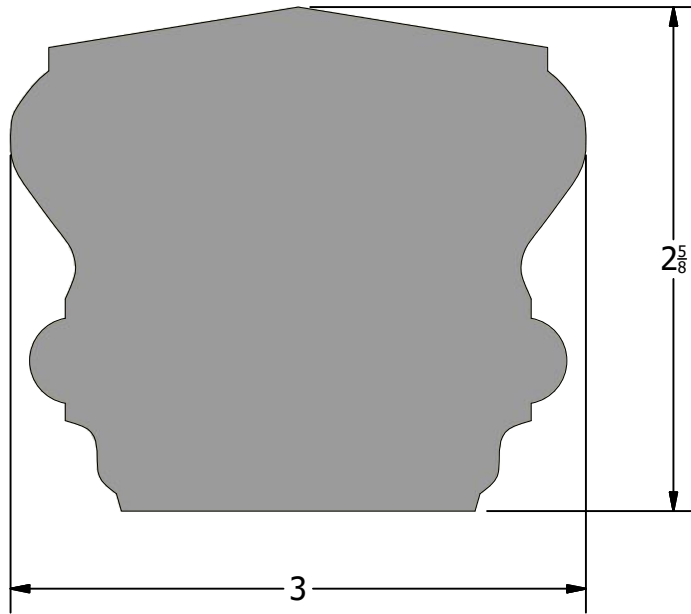

Description
Hand Rail

Part Number
HR-07

-421-

Back

Scale 1 : 1

HOMESTEAD
WOODWORKS

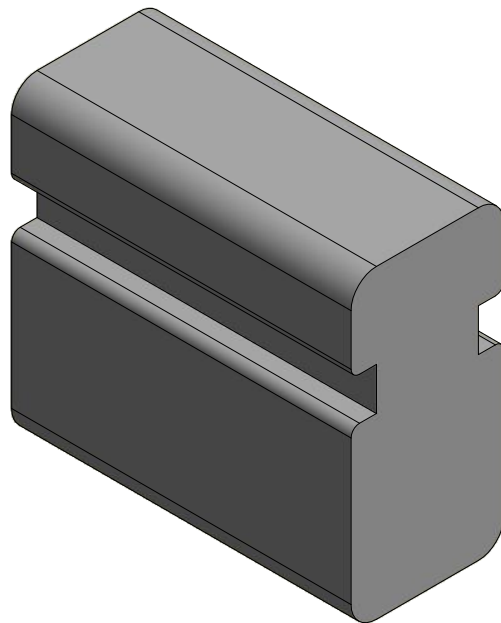
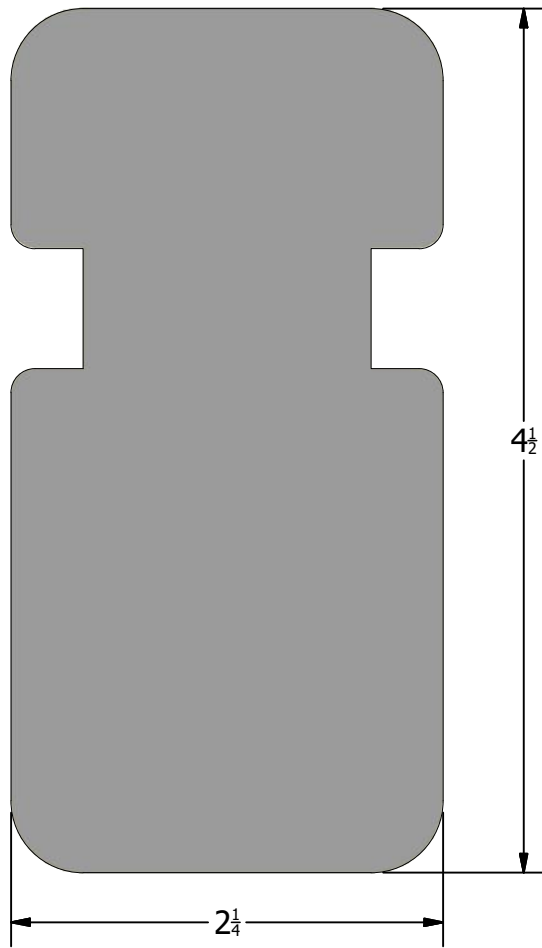

Description
Hand Rail

Part Number
HR-08

-422-

Back

Scale 1 : 1



HOMESTEAD
WOODWORKS

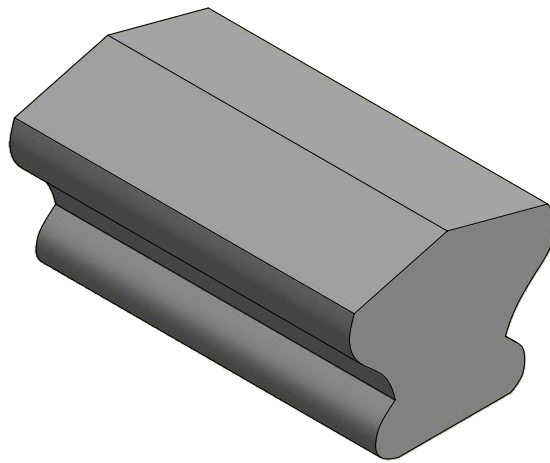
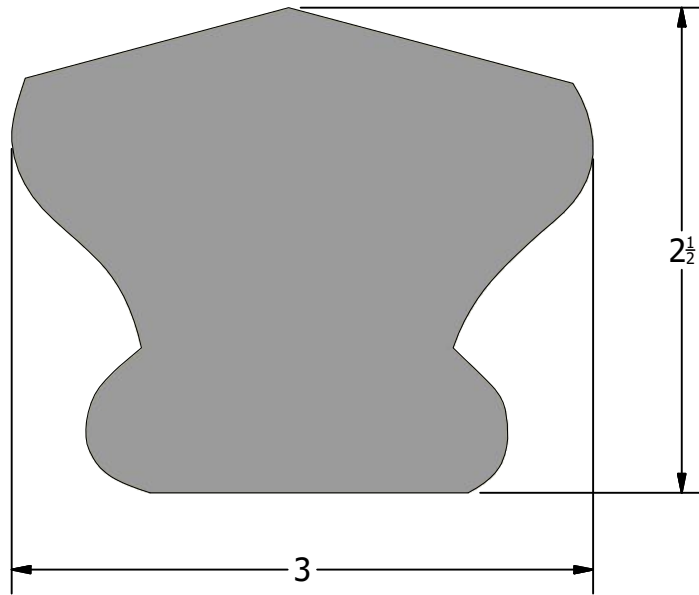

Description
Hand Rail

Part Number
HR-09

-423-

Back

Scale 1 : 1



HOMESTEAD
WOODWORKS

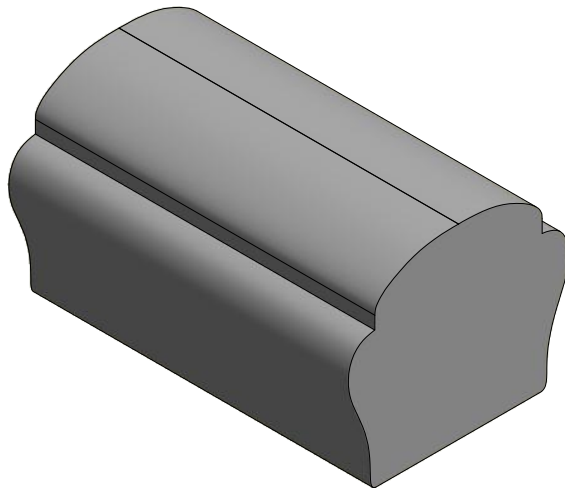
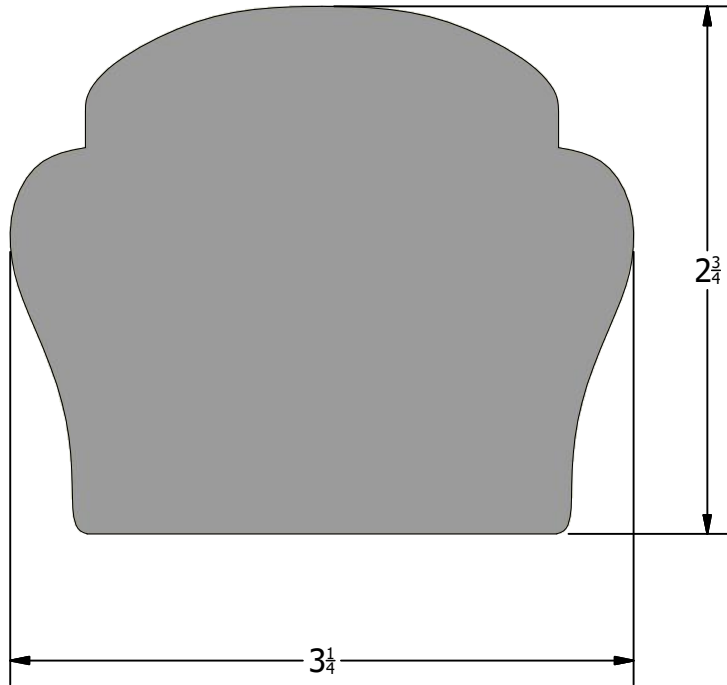

Description Hand Rail		Part Number HR-10	 HOMESTEAD WOODWORKS
-424-	Back	Scale 1 : 1	

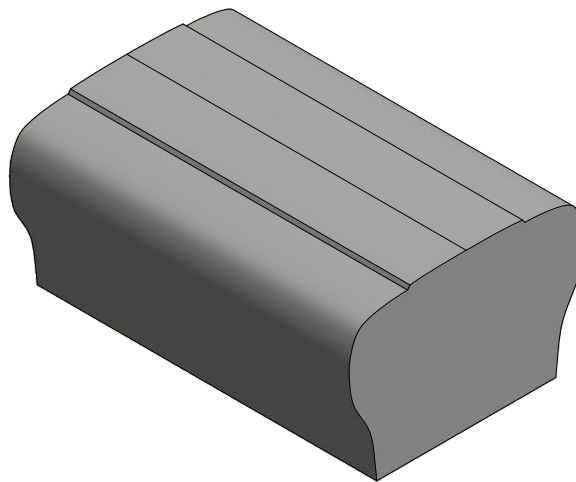
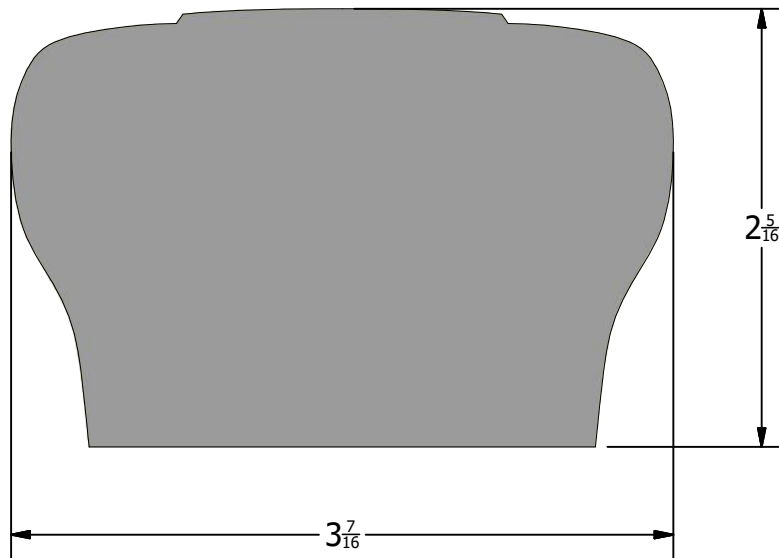

Description Hand Rail		Part Number HR-11	 HOMESTEAD WOODWORKS
-425-	Back	Scale 1 : 1	

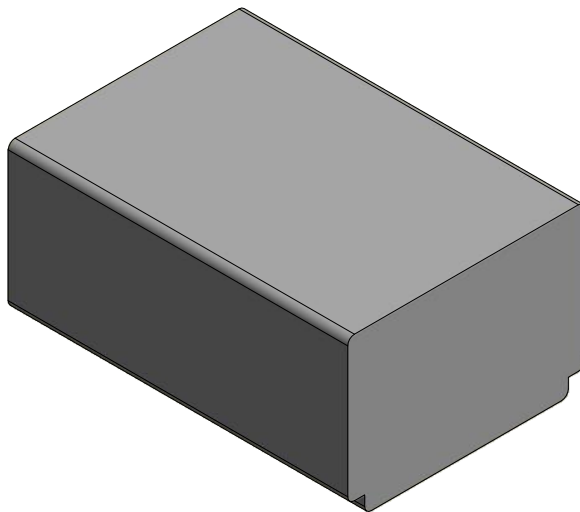
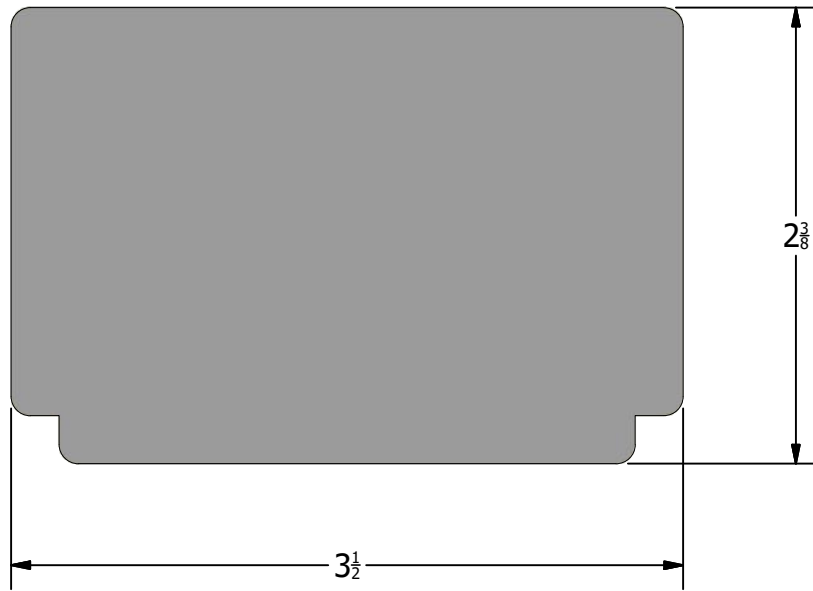

Description Hand Rail		Part Number HR-12-A	 HOMESTEAD WOODWORKS
-426-	Back	Scale 1 : 1	

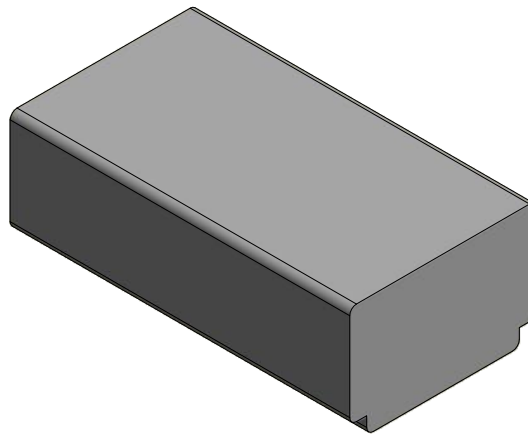
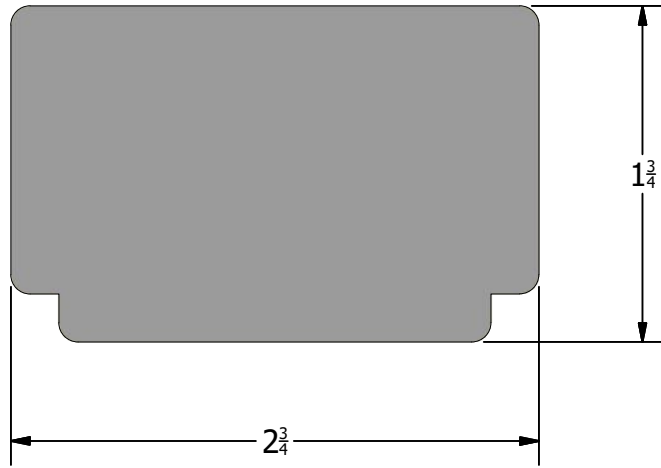

Description
Hand Rail

Part Number
HR-12-B



-427-

Back

Scale 1 : 1

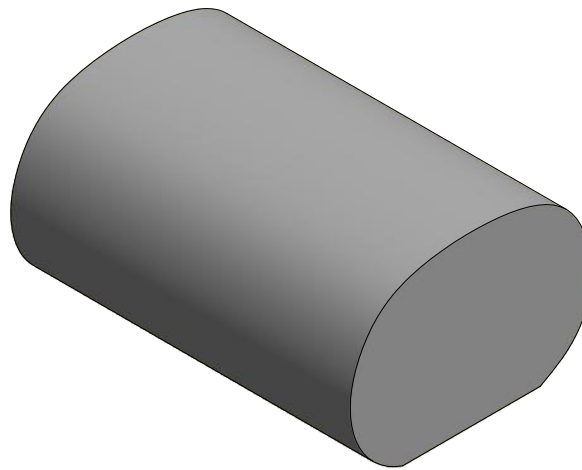
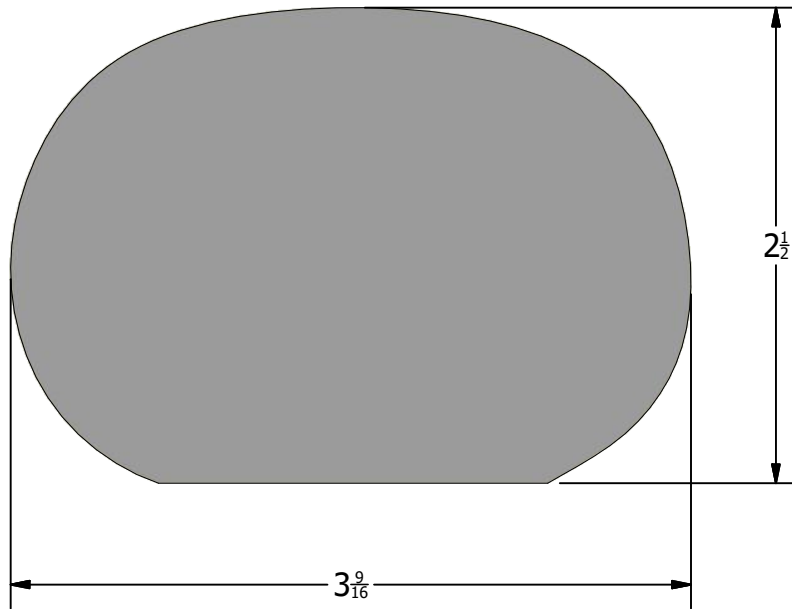

Description
Hand Rail

Part Number
HR-13



-428-

Back

Scale 1 : 1

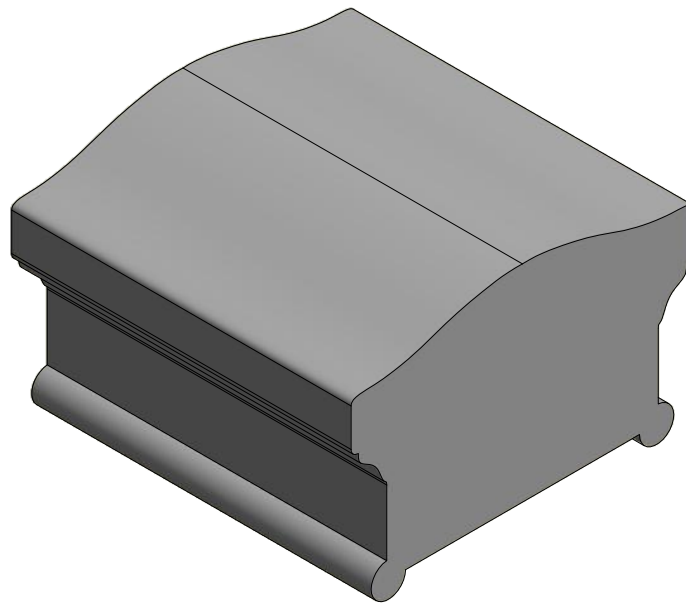
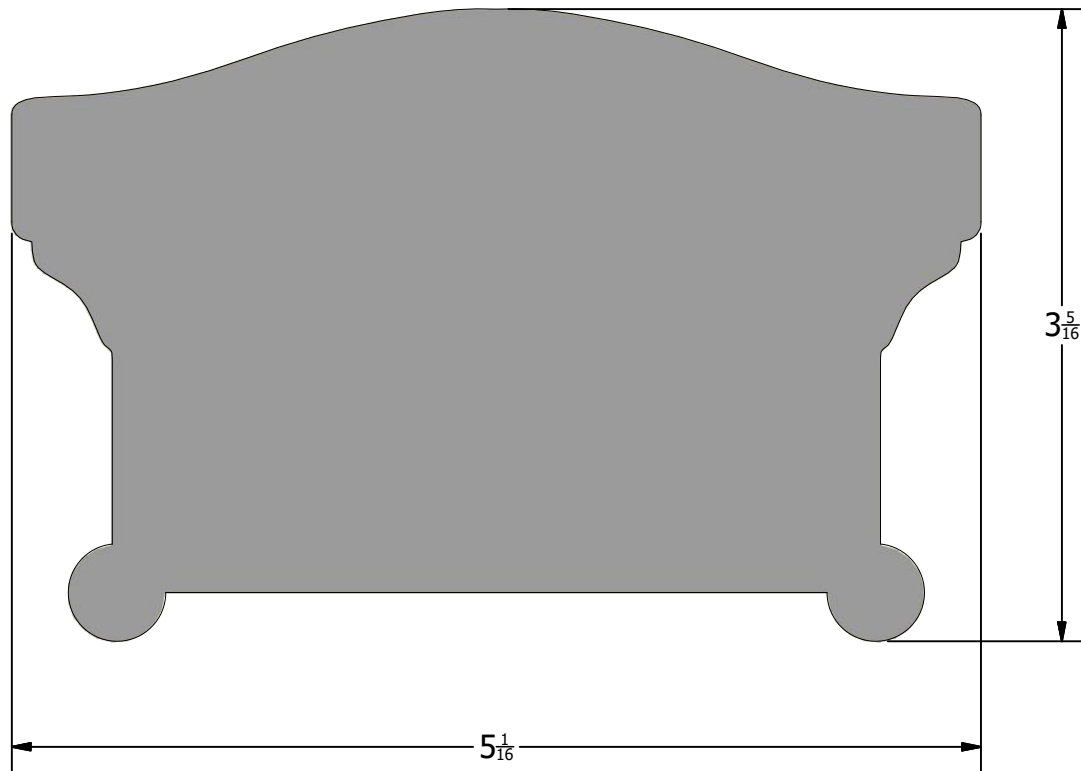

Description Hand Rail		Part Number HR-14	 HOMESTEAD WOODWORKS
-429-	Back	Scale 1 : 1	

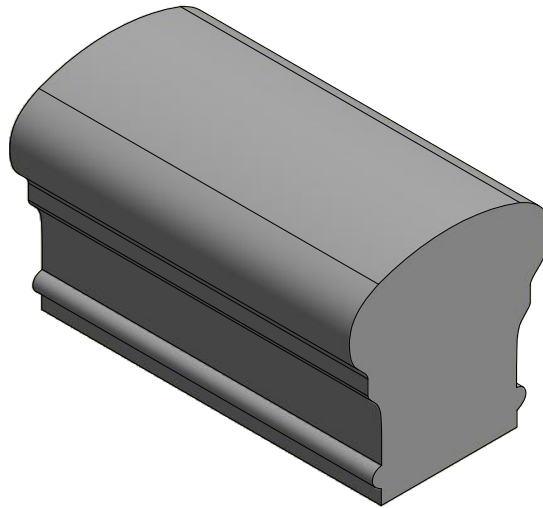
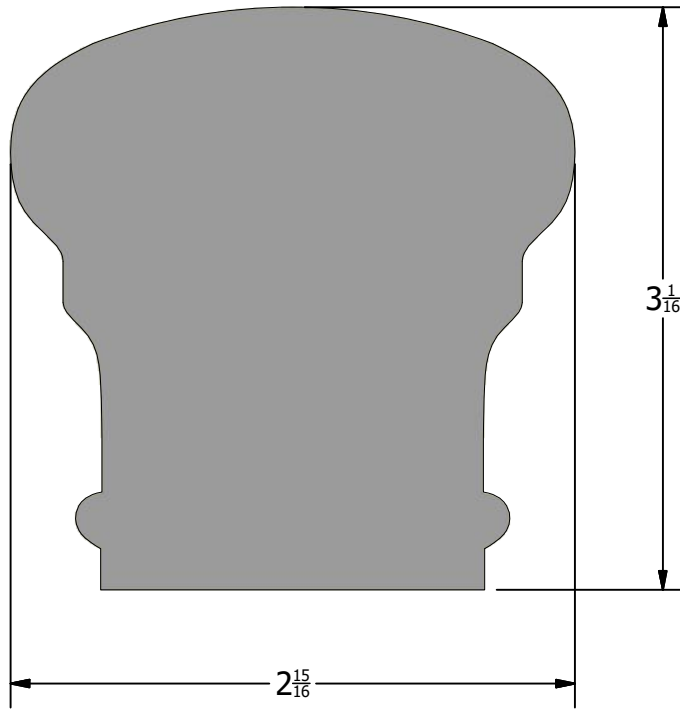

Description Hand Rail		Part Number HR-15	 HOMESTEAD WOODWORKS
-430-	Back	Scale 1 : 1	

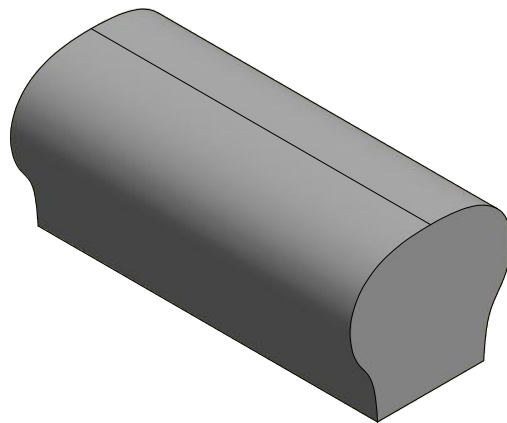
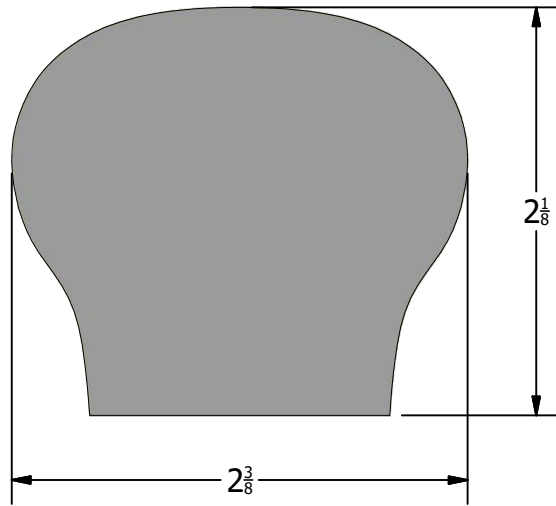

Description
Hand Rail

Part Number
HR-16

-431-

Back

Scale 1 : 1



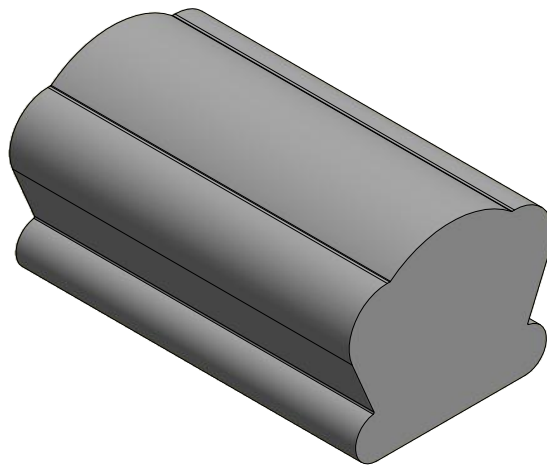
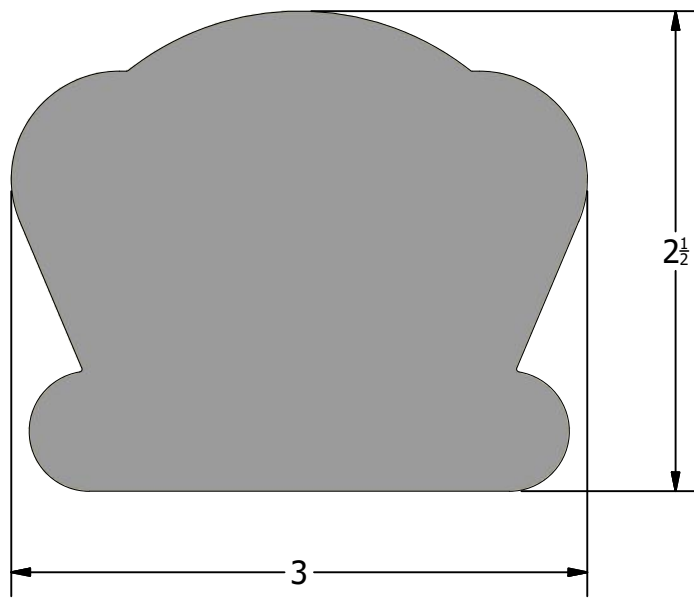

Description
Hand Rail

Part Number
HR-17

-432-

Back

Scale 1 : 1



HOMESTEAD
WOODWORKS

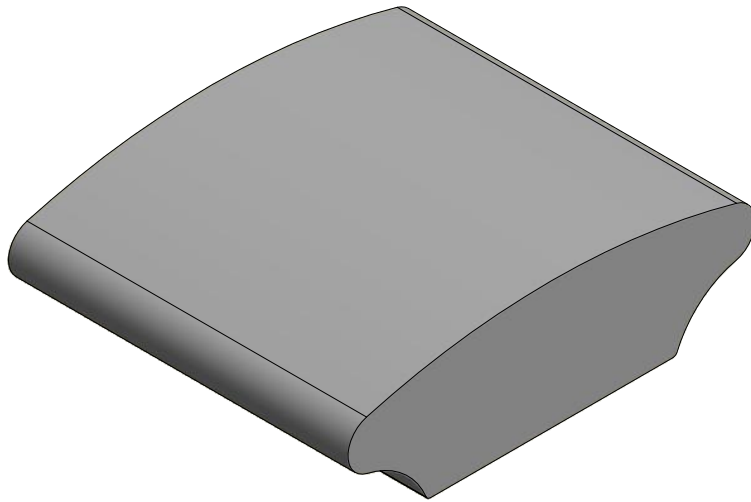
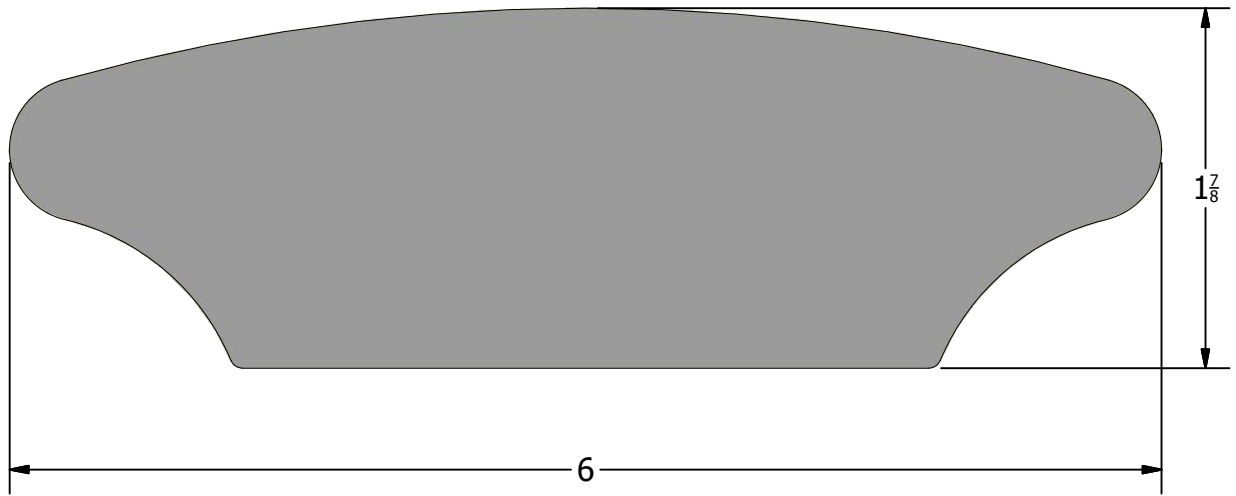

Description
Hand Rail

Part Number
HR-18



-433-

Back

Scale 1 : 1

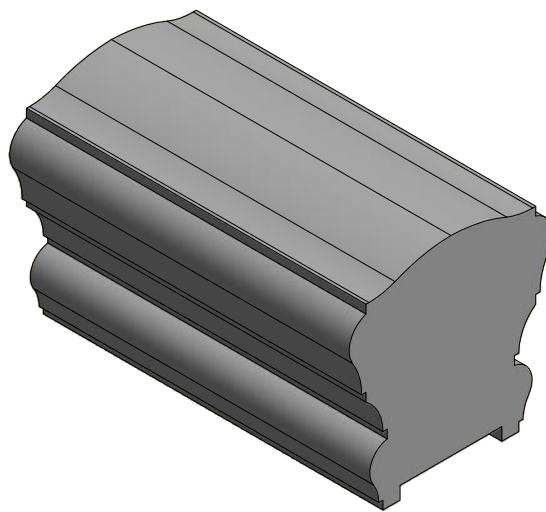
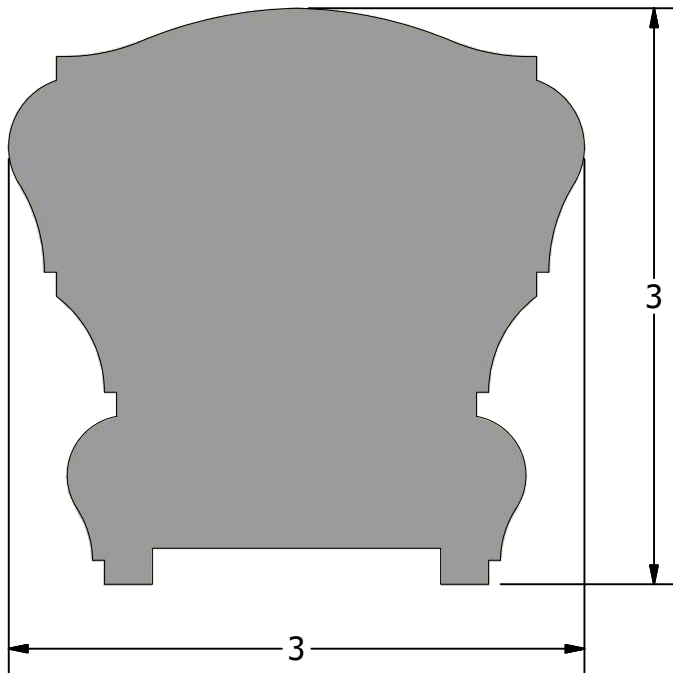

Description
Hand Rail

Part Number
HR-19

-434-

Back

Scale 1 : 1

HOMESTEAD
WOODWORKS

Description

Part Number

-435-

Back

Scale



HOMESTEAD
WOODWORKS

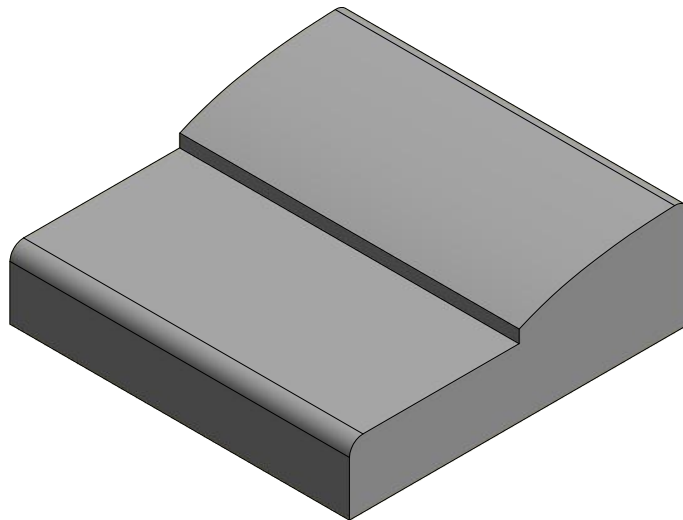
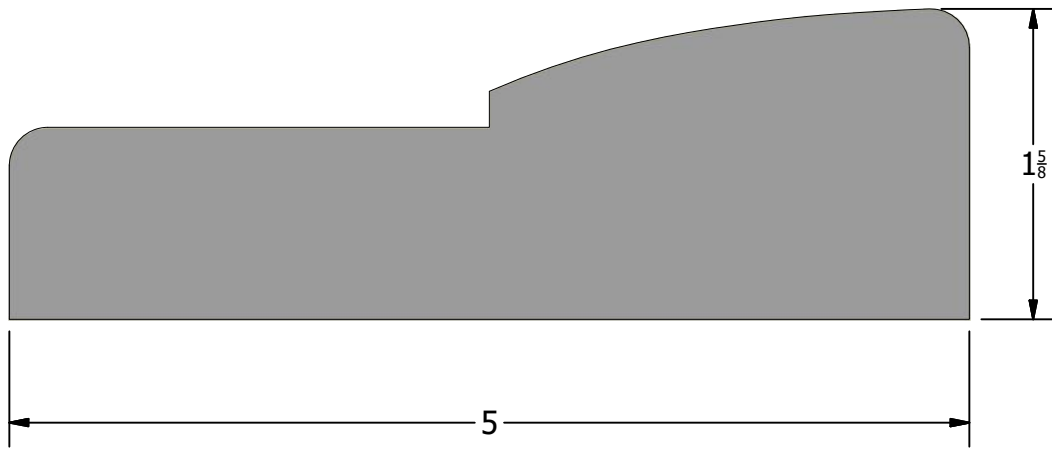

Description
Plinth Block

Part Number
Plinth-01

-436-

Back

Scale 1 : 1



HOMESTEAD
WOODWORKS

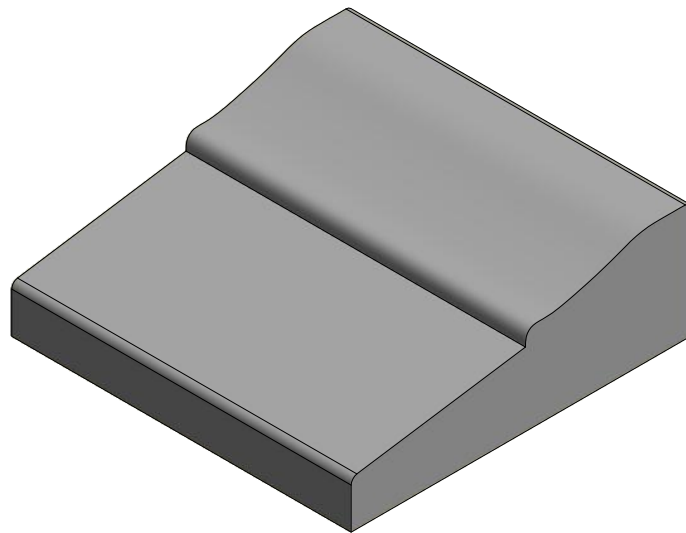
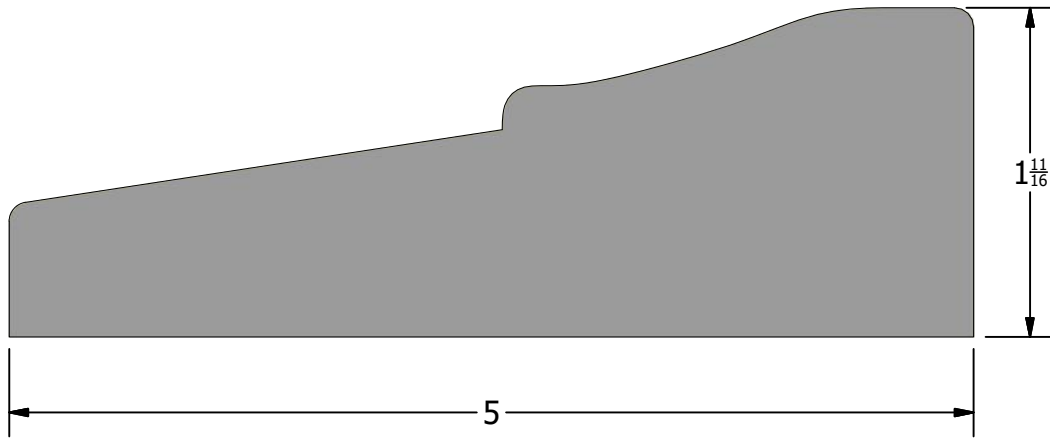

Description
Plinth Block

Part Number
Plinth-02

-437-

Back

Scale 1 : 1



HOMESTEAD
WOODWORKS

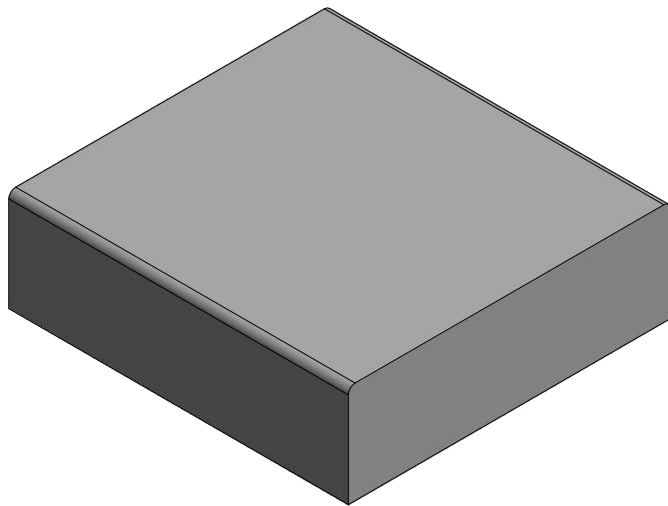

Description
Plinth Block

Part Number
Plinth-03

-438-

Back

Scale 1 : 1



HOMESTEAD
WOODWORKS

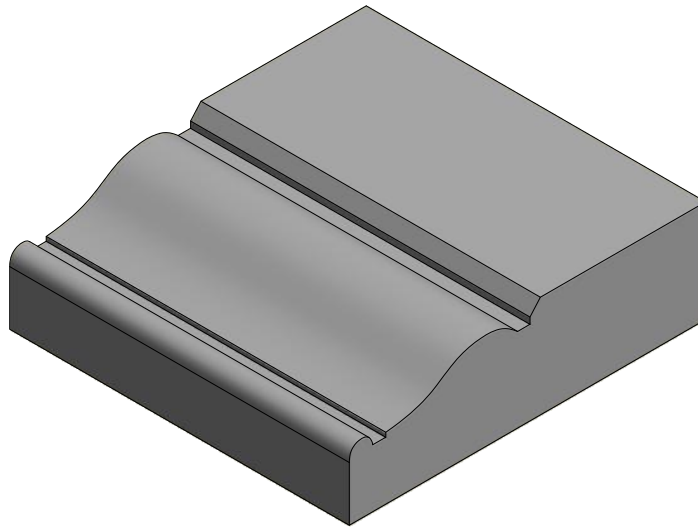
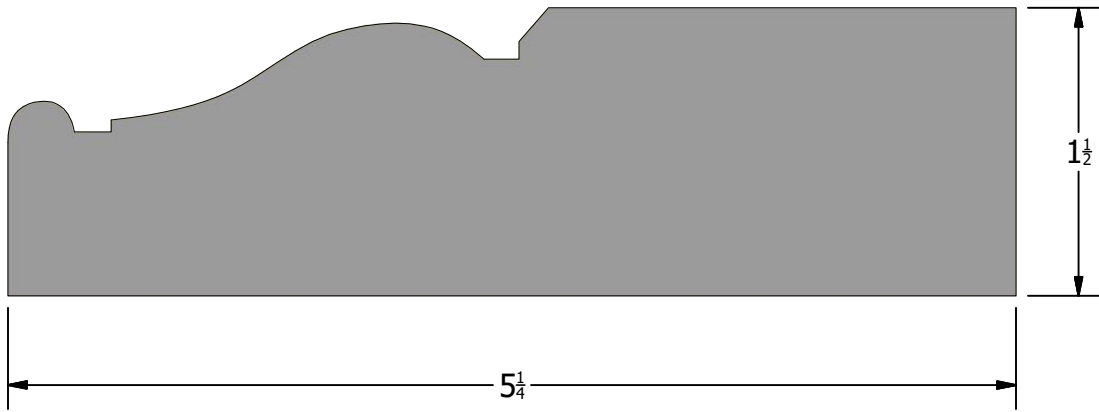

Description
Plinth Block

Part Number
Plinth-04

-439-

Back

Scale 1 : 1



HOMESTEAD
WOODWORKS

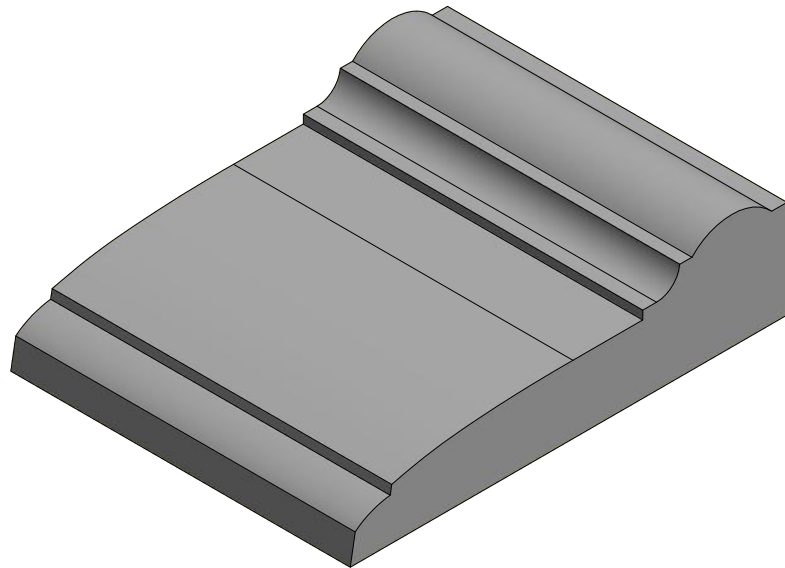
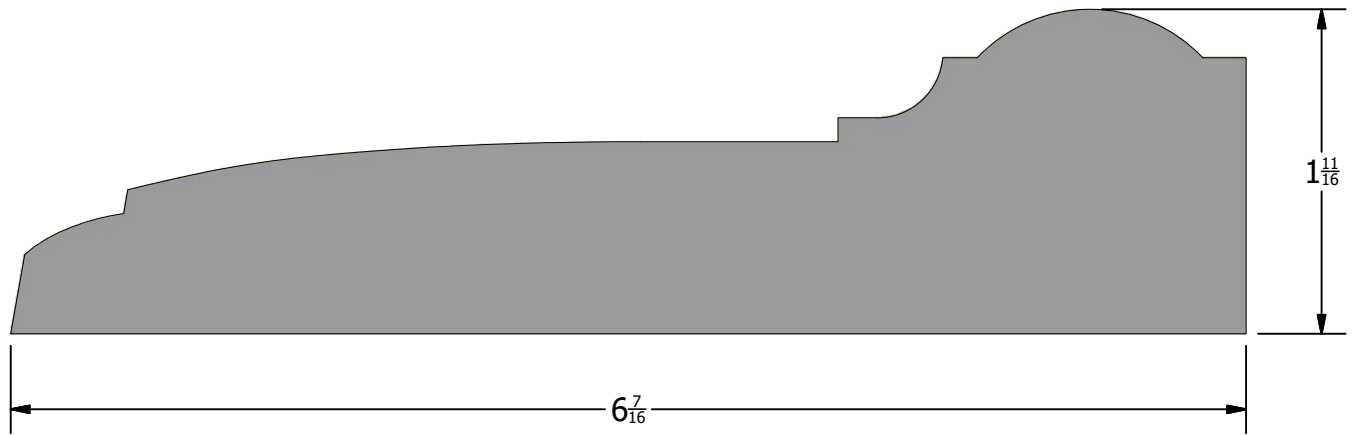

Description Plinth Block		Part Number Plinth-05	 HOMESTEAD WOODWORKS
-440-	Back	Scale 1 : 1	

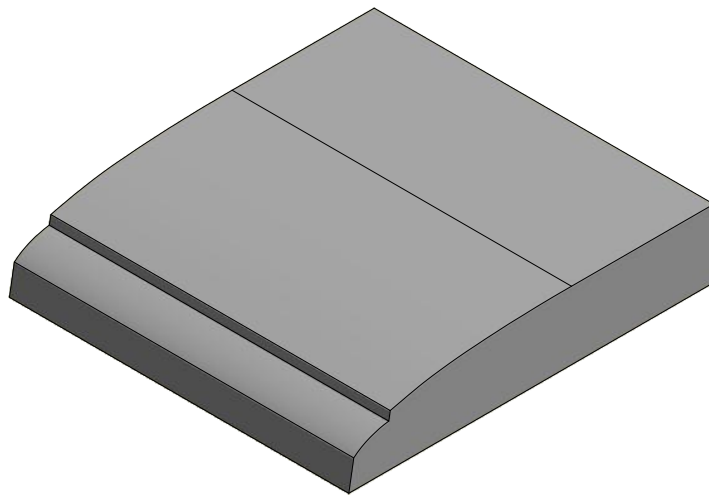
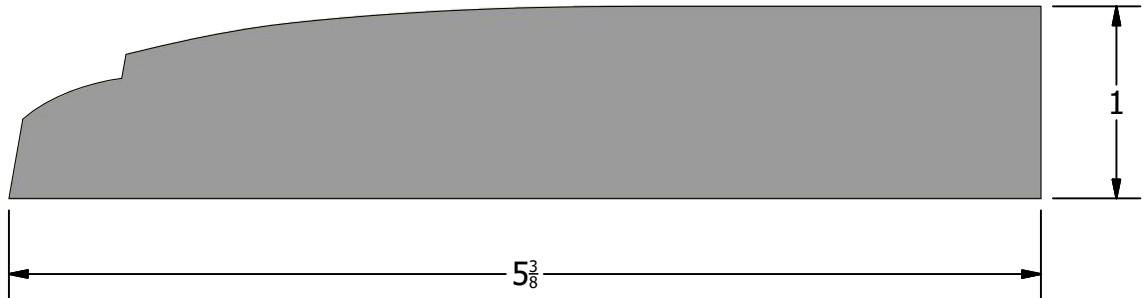

Description
Plinth Block

Part Number
Plinth-06

-441-

Back

Scale 1 : 1



HOMESTEAD
WOODWORKS

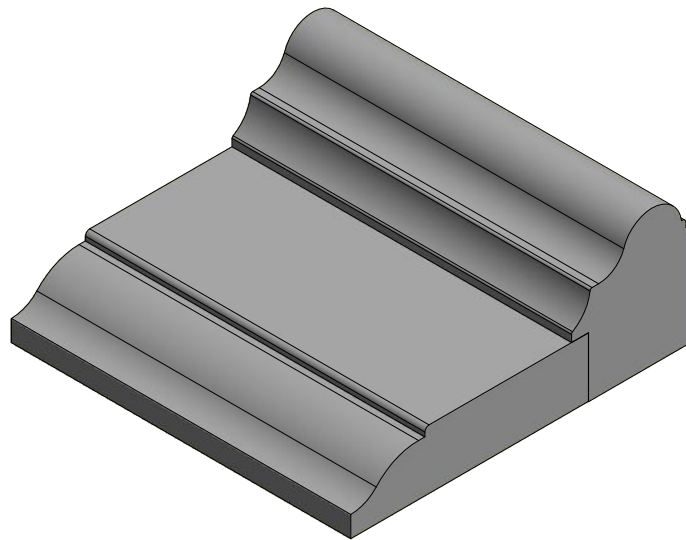
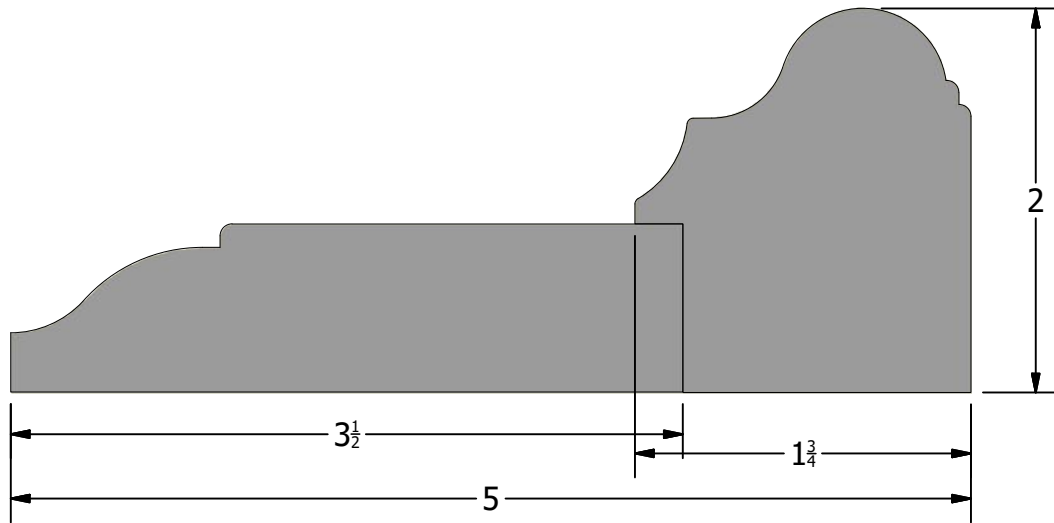

Description Plinth Block		Part Number Plinth-07	 HOMESTEAD WOODWORKS
-442-	Back	Scale 1 / 2	

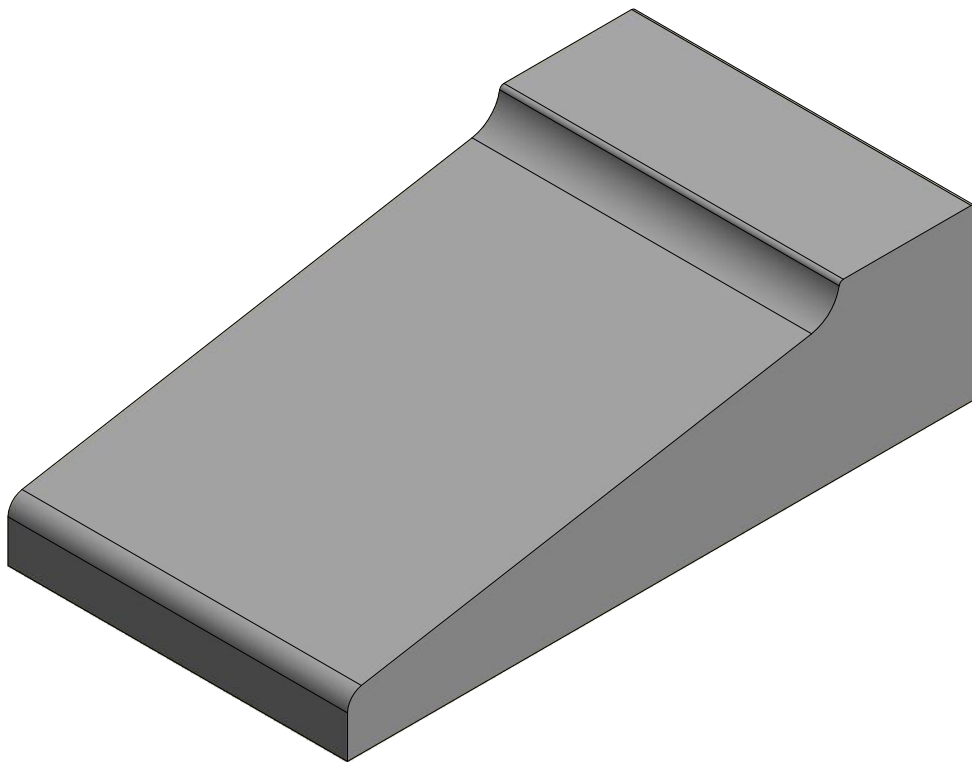
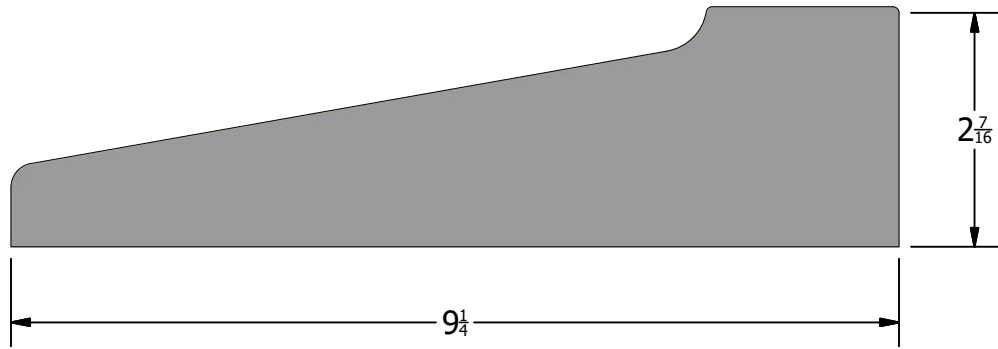

Description
Plinth Block

Part Number
Plinth-08

-443-

Back

Scale 1 / 2



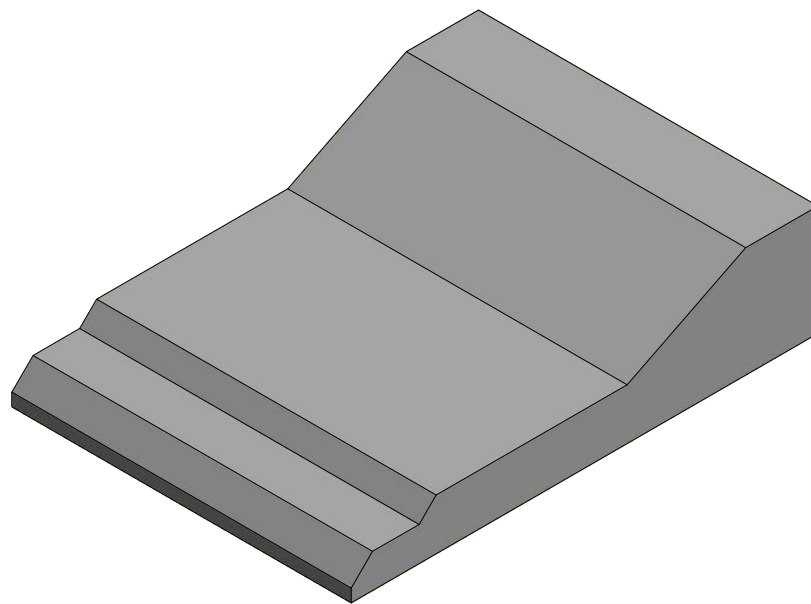
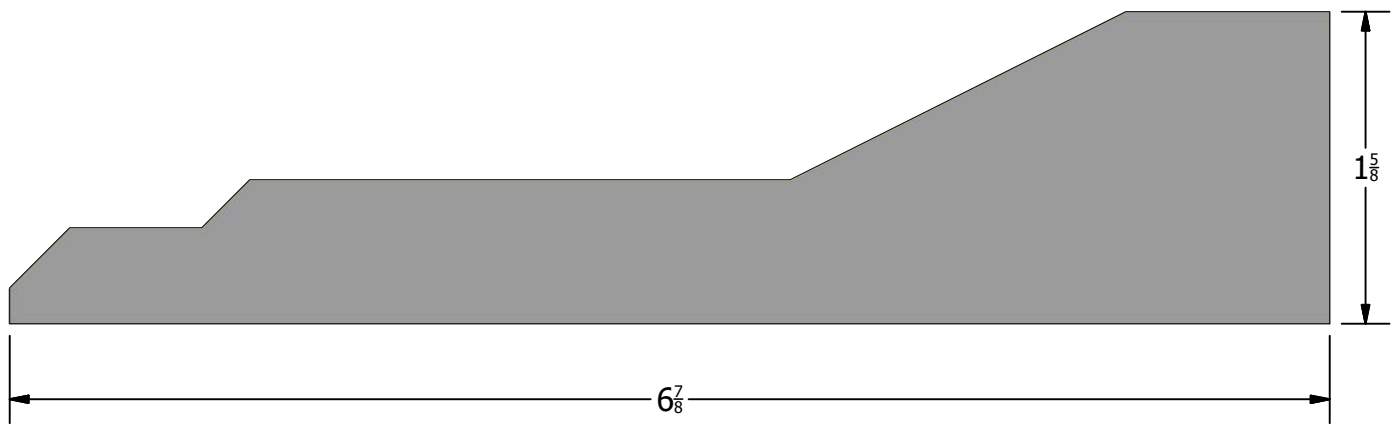

Description Plinth Block		Part Number Plinth-09	 HOMESTEAD WOODWORKS
-444-	Back	Scale 1 : 1	

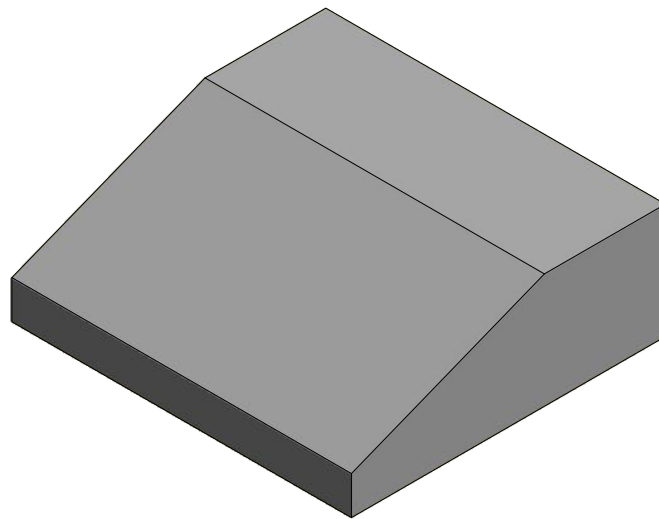
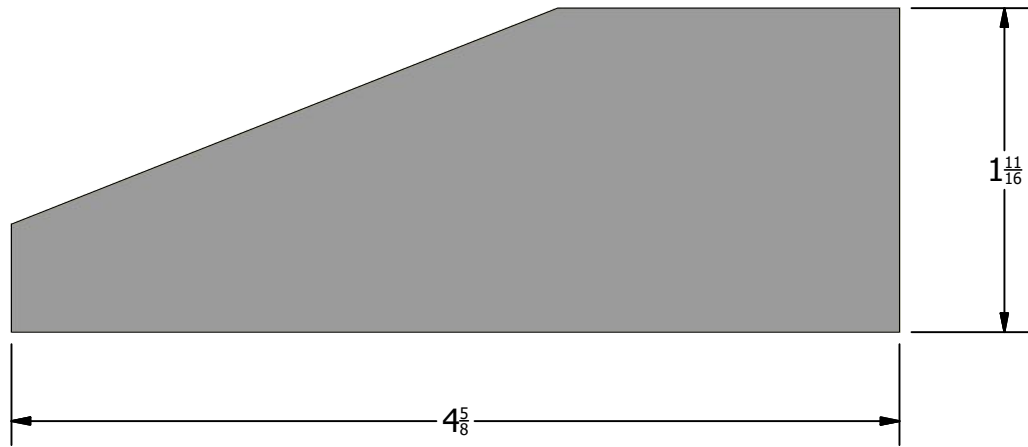

Description Plinth Block		Part Number Plinth-10	 HOMESTEAD WOODWORKS
-445-	Back	Scale 1 : 1	

Description

Part Number

-446-

Back

Scale



HOMESTEAD
WOODWORKS

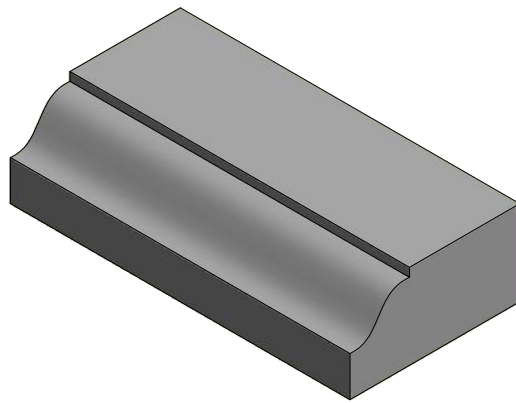
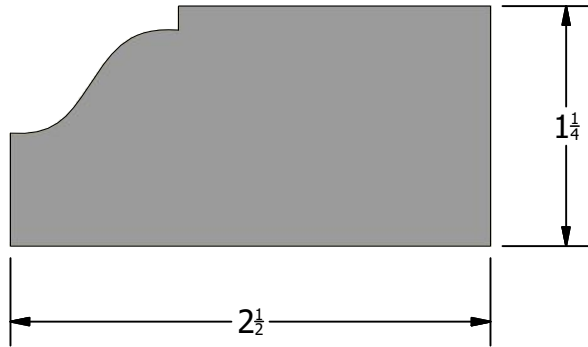

Description
Brick Mould

Part Number
BM-01

-447-

Back

Scale 1 : 1



HOMESTEAD
WOODWORKS

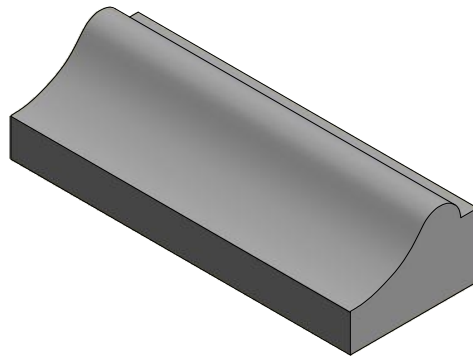
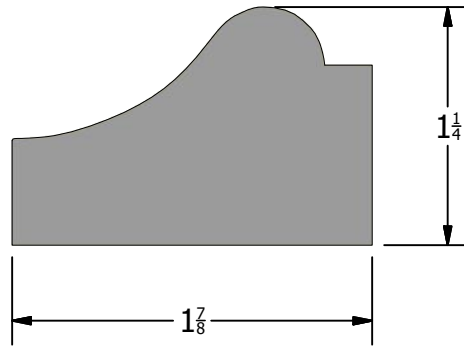

Description
Brick Mould

Part Number
BM-02

-448-

Back

Scale 1 : 1



HOMESTEAD
WOODWORKS

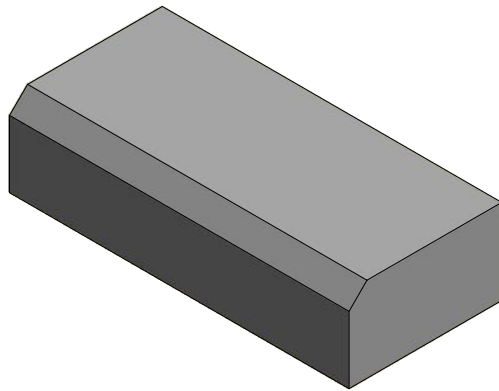
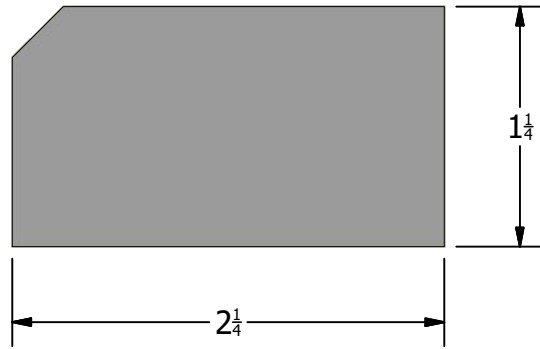

Description
Brick Mould

Part Number
BM-03

-449-

Back

Scale 1 : 1



HOMESTEAD
WOODWORKS

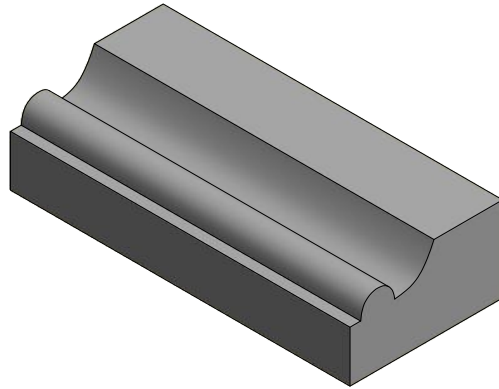
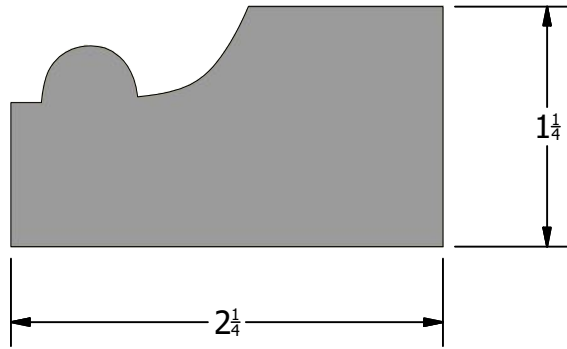

Description
Brick Mould

Part Number
BM-04

-450-

Back

Scale 1 : 1



HOMESTEAD
WOODWORKS

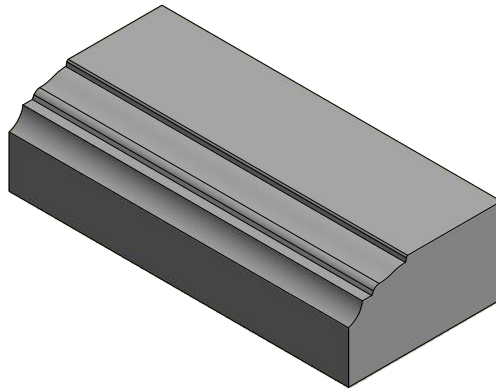
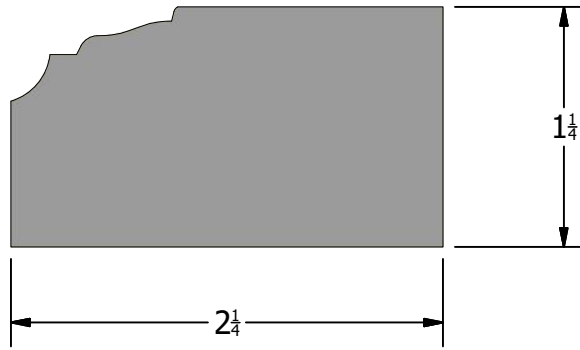

Description
Brick Mould

Part Number
BM-05

-451-

Back

Scale 1 : 1



HOMESTEAD
WOODWORKS

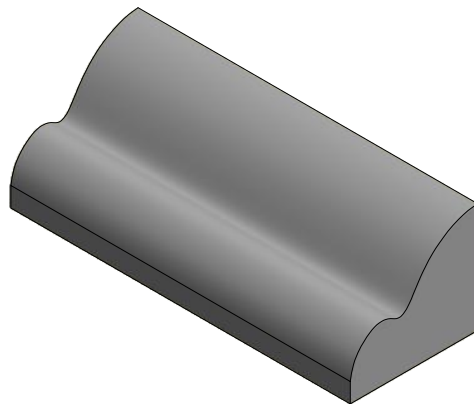
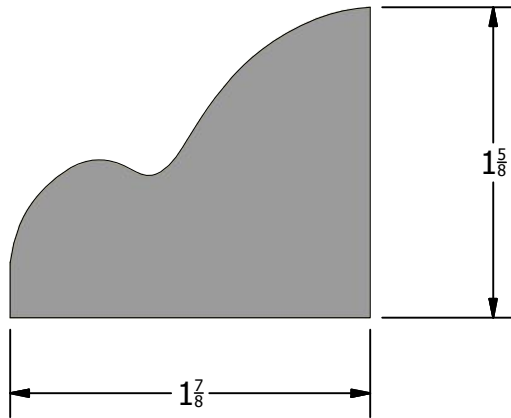

Description
Brick Mould

Part Number
BM-06

-452-

Back

Scale 1 : 1



HOMESTEAD
WOODWORKS

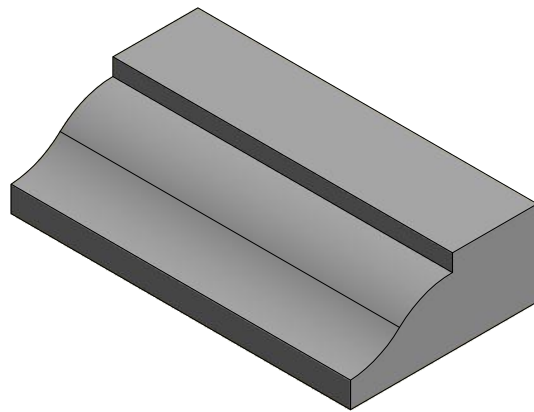

Description
Brick Mould

Part Number
BM-07

-453-

Back

Scale 1 : 1



HOMESTEAD
WOODWORKS

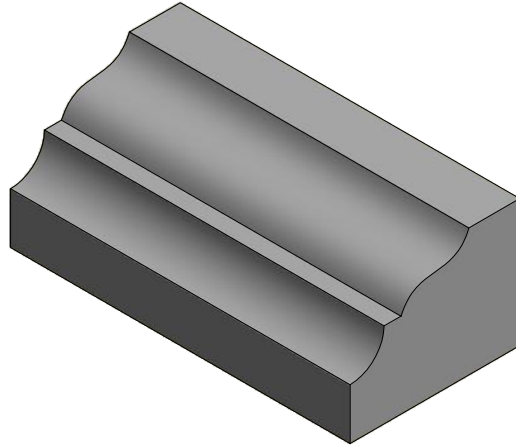
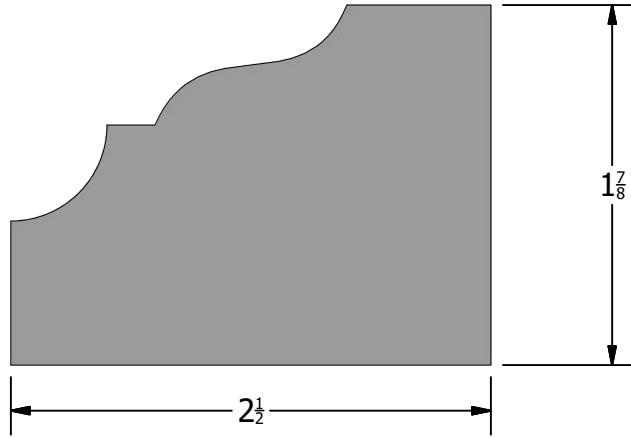

Description
Brick Mould

Part Number
BM-08

-454-

Back

Scale 1 : 1



HOMESTEAD
WOODWORKS

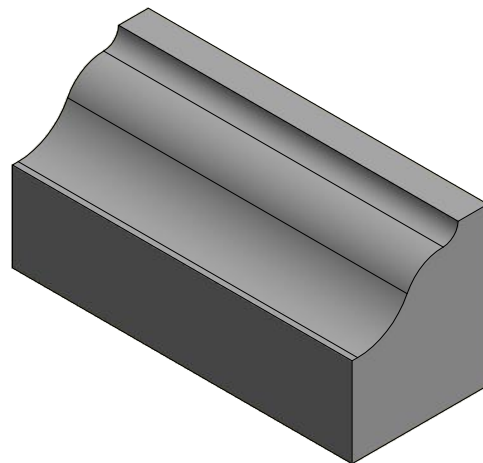
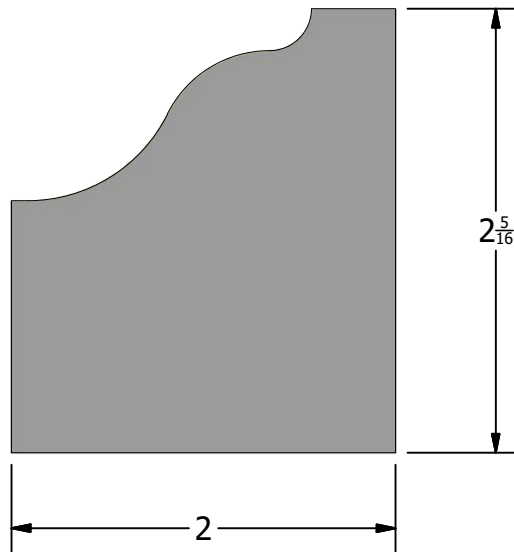

Description
Brick Mould

Part Number
BM-09

-455-

Back

Scale 1 : 1



HOMESTEAD
WOODWORKS

Description

Part Number

-456-

Back

Scale



HOMESTEAD
WOODWORKS



3575 Boadway Street
Hawkesville, Ontario N0B 1X0
519-699-4529
www.hsww.ca



HOMESTEAD
WOODWORKS